

Vehicle Tracking System Using GPS/GSM Technology

Nabarun Ghosh
Master of Engineering,
University Institute of Technology
Under Burdwan University,
West Bengal.

Koushik Bishayee, Ph.D Pursuing
Assistant Professor,
University Institute of Technology
Under Burdwan University,
West Bengal.

ABSTRACT:

Security in travel is primary concern for every one. This Project describes a design of effective alarm system that can monitor an automotive / vehicle / car condition in traveling. This project is designed to inform about an accident that is occurred to a vehicle to the family members of the traveling persons. This project uses a piezo-electric sensor which can detect the abrupt vibration when an accident is occurred. This sends a signal to microcontroller.

This Project presents an automatic vehicle accident detection system using GPS and GSM modems. The system can be interconnected with the car alarm system and alert the owner on his mobile phone. This detection and messaging system is composed of a GPS receiver, Microcontroller and a GSM Modem. GPS Receiver gets the location information from satellites in the form of latitude and longitude.

The Microcontroller processes this information and this processed information is sent to the user/owner using GSM modem A GSM modem is interfaced to the MCU. The GSM modem sends an SMS to the predefined mobile number and informs about this accident. This enable it to monitor the accident situations and it can immediately alerts the police/ambulance service with the location of accident. The project is built around the LPC2148 micro controller.

This micro controller provides all the functionality of the SMS alert system. It also takes care of filtering of the signals at the inputs. The uniqueness of this project is, not only alerting the neighbors by its siren, but also it sends a caution SMS to four mobile numbers. These numbers are stored in EEPROM. This project uses regulated 3.3V, 750mA power supply. 7805 three terminal voltage regulator is used for voltage regulation. Bridge type full wave rectifier is used to rectify the ac out put of secondary of 230/12V step down transformer.

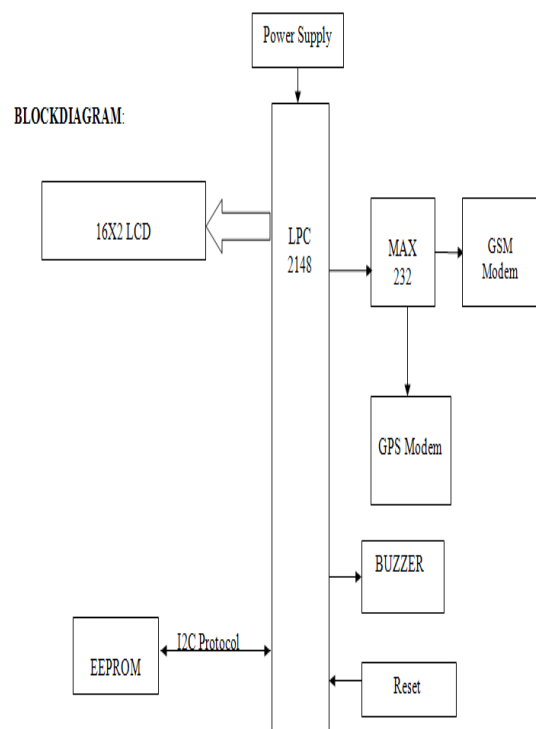
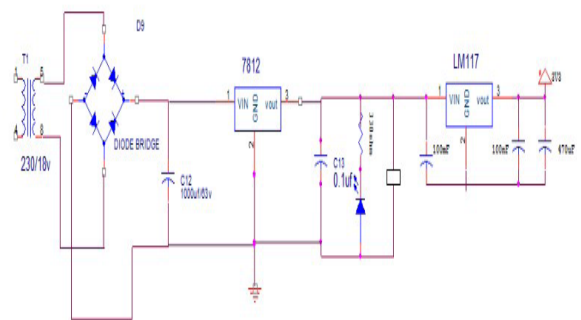

I. Hardware requirements LPC2148 controller

The LPC2148 are based on a 16/32 bit ARM7TDMI-S™ CPU with real-time emulation and embedded trace support, together with 128/512 kilobytes of embedded high speed flash memory.

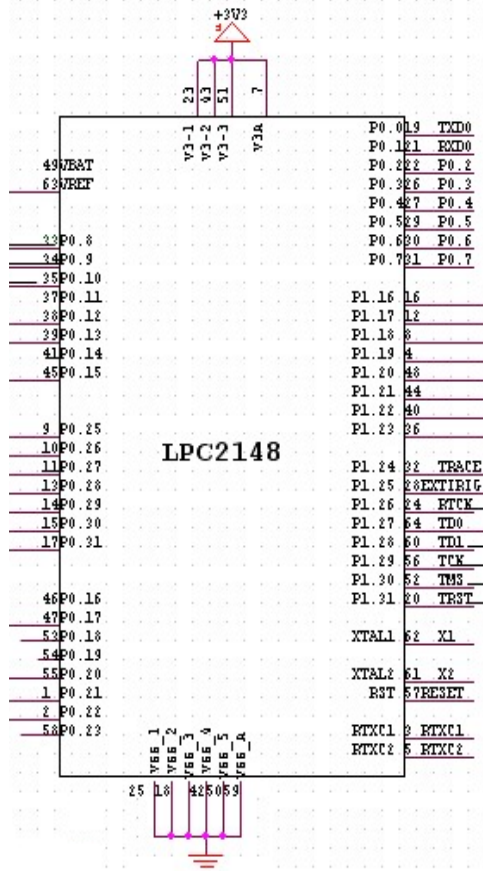

- Has EEPROM interface using I2C.
- Has PS2 keyboard interface.
- All port pins are extracted externally for further interfaces.



Global System for Mobile communication (GSM)

Definition:

GSM, which stands for Global System for Mobile communications, reigns (important) as the world's most widely used cell phone technology. Cell phones use a cell phone service carrier's GSM network by searching for cell phone towers in the nearby area. Global system for mobile communication (GSM) is a globally accepted standard for digital cellular communication.

Specifications of Board

- Use 16/32 Bit ARM7TDMI-S MCU No.LPC2148 from Philips (NXP)
- Has 512KB Flash Memory and 40KB Static RAM internal MCU
- Use 12.00MHz Crystal, so MCU can process data with the maximum high speed at 60MHz when using it with Phase-Locked Loop (PLL) internal MCU.
- Has RTC Circuit (Real Time Clock) with 32.768 KHz XTAL and Battery Backup.
- Support In-System Programming (ISP) and In-Application Programming (IAP) through On-Chip Boot-Loader Software via Port UART-0 (RS232)
- Has circuit to connect with standard 20 Pin JTAG ARM for Real Time Debugging
- 7-12V AC/DC Power Supply.
- Has standard 2.0 USB as Full Speed inside (USB Function has 32 End Point)
- Has Circuit to connect with Dot-Matrix LCD with circuit to adjust its contrast by using 16 PIN Connector.
- Has RS232 Communication Circuit by using 2 Channel.
- Has SD/MMC card connector circuit by using SSP.

TABLE I. SOME COMMANDS USED IN GSM DATA TRANSFER MODULE OF THE SYSTEM

AT Command	Meaning
+CMGI	Module ok
+CMGS	Send message
+CMGW	Write message to memory
+CMGD	Delete message
+CMGC	Send command
+CMSS	Send message from storage

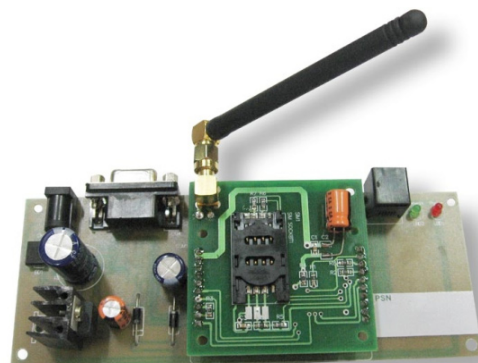

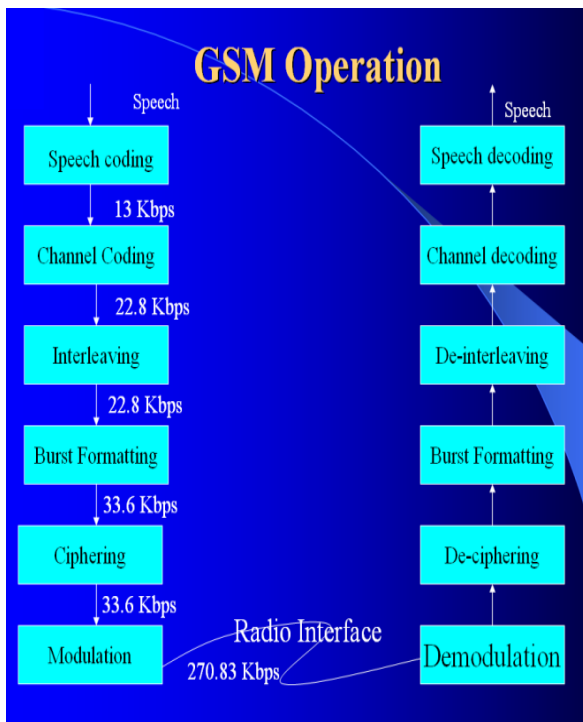

MODEM SPECIFICATIONS:

The SIM300 is a complete Tri-band GSM solution in a compact plug-in module. Featuring an industry-standard interface, the SIM300 delivers GSM/GPRS900/1800/1900Mhz performance for voice, SMS, data and Fax in a small form factor and with low power consumption.

Advantages:

- Sophisticated security
- Monitors all hazards and threats
- Alert message to mobile phone for remote information
- Mobile number can be changed at any time

Applications:

- Automotives and transport vehicles
- Security, Remote monitoring, Transportation and logistics
- This system is also can be interfaced with Vehicle airbag system.

CONCLUSION:

The GPS tracking and GSM alert based algorithm is designed and implemented with LPC2148 Microcontroller in embedded system domain in traveling.

REFERENCES:

1. "Nearly half of American adults are Smartphone", Aaron Smith, <http://pewinternet.org/~media/Files/Reports/2012/Smartphone%20ownership%202012.pdf>, 2012
2. Minu Balan, Sharoon Thomas, and Lynn Mariette Mendonza, Jithin V mohan, "Fleet Mangement System", B.Tech Degree Thesis, College of Engineering, Munnar, Idukki, Kerala, India, 2009
3. Mohammad A. Al-Khedher, "Hybrid GPS-GSM Localization of Automobile Tracking System", International Journal of Computer Science & Information Technology (IJCSIT) Vol 3, No 6, Dec 2011 [CrossRef]
4. Saed Tarapiah, Shadi Atalla, and Rajaa AbuHania, "Smart On-Board Transportation Management System Using GPS/GSM/GPRS Technologies to Reduce Traffic Violation in Developing Countries", International Journal of Digital Information and Wireless Communications (IJDWC) 3(4): 96-105, The Society of Digital Information and Wireless Communications, 2013 (ISSN: 2225-658X)
5. Muruganandham, "Real Time Web based Vehicle Tracking using GPS", World Academy of Science, Engineering and Techonogy, 37, 2010
6. R. Ramani, S. Valarmathy, N. Suthanthira Vanitha, S. Selvaraju, and M. Thirupathi, "Vehicle Tracking and Locking Sytem Based on GSM and GPS", I.J. Intelligent Systems and Applications, 2013, 09, 86-93
7. G. Kiran Kumar, A. Mallikarjuna Prasad, "Public Transportation Mangement Service using GPS-GSM", International Journal of Research in Computer and Communication Technology, IJRCCT, ISSN-2278-5841, Vol-1, Issue-3, Aug-2012.
8. Ambade Shruti Dinker and S. A Shaikh, "Design and Implementation Of vehicle Tracking System Using GPS", Journal of Information Engineering and Applications, Vol 1, No.3, 2011
9. Eddie Chi-Wah Lau, "Simple Bus Tracking System", Journal of Advanced Computer Science and Technology Research, Vol3, No.1, 2013
10. Montaser N. Ramadan, Mohammad A. Al-Khedher, and Sharaf A. Al-Kheder, "Intelligent Anti-Theft and Tracking Sytem for Automobiles", International Journal of Machine Learning and Computing Vol.2 No. 1, February 2012.