

Reverse Motion Technique in Bike

Mohammad Ahmad

Department of Mechanical
Engineering,
Hyderabad Institute of Technology
and Management,
Hyderabad-501401

Mohit Jain

Department of Mechanical
Engineering,
Hyderabad Institute of Technology
and Management,
Hyderabad-501401

Md Irfan

Department of Mechanical
Engineering,
Hyderabad Institute of Technology
and Management,
Hyderabad-501401

N.Gopi Chand

Department of Mechanical Engineering,
Hyderabad Institute of Technology and Management,
Hyderabad-501401

Mrs.Baby Theresa.G

Assistant Professor, Department of ME,
Hyderabad Institute of Technology and Management,
Hyderabad-501401

ABSTRACT

In modern world different types of vehicles are innovated. But until now it is a major problem for the physically challenged peoples to move back the vehicles. Even to a small distance they cannot move the vehicles backside. So To eliminate this problem we invent the reverse gear technique in two wheeler. The challenged peoples can easily reverse the vehicles without getting down from the vehicle by easily operating hand lever. The project title is "REVERSE MOTION TECHNIQUE IN BIKE". The main objective of our project is to facilitate 'comfort ability and safety' to the challenged peoples. This project requires the engine power, lever, reverse gear box, chain, sprocket, spur gear, bearing and other necessary parts. When need to reverse the vehicles they can engage the hand lever for reverse gear, the vehicle moves backwards. This project will be more useful for the challenged peoples in the society.

Key word: *Spur gear, Gear train, Divide power transmission from gearbox to rear wheel*

INTRODUCTION:

In bikes, the power transmission generally is connected to the engine crankshaft via a flywheel and or partly because inter combustion engines cannot run below a particular speed. Transmission may be Directional i.e. Forward and Reverse control may be provided. Reverse gear mechanism is used to transmit

the power in reverse direction. The reverse gear was used in locomotive engine in order to stop the Train. The later it was used in three wheelers (Auto) and it became a prominent feature of four wheelers. Recently the reverse gear mechanism is implemented in two wheelers also for various applications. To design reverse motion technique in a two wheeler Engine. To fabricate the designed gear mechanism. The main Moto of our project is to fit the reverse gear mechanism in differently able person's vehicles because they find it difficult to move the vehicle backward without the help of others. A simple but rugged sliding- mesh or unsynchronized/non-synchronous system, where straight-cut spur gear sets spin freely, and we get reverse motion

NEED OF PROJECT:

- To eliminate the partiality and complexity nature over the handicap peoples from the society.
- To improve the tendency and ability of challengers to live with confidence and without considering the illness and disability of them.
- To get back the hopeful of handicap to show the strength of them to society.
- To eliminate the effort required for taking the vehicle backward.
- To provide reverse mechanism in two wheeler at lower costs.

SCOPE OF PROJECT:

- To provide a better convenient chariot ride feel while driving in roadways to physical challengers.
- It is Suitable for the person, who have problem in leg.
- It is Suitable for the person, who have problem in ear.
- It makes people convenient and stress free who are not physically challenged while taking the vehicle backward.
- The vehicle can be reversed at appropriate speed without causing any danger.

DESIGN AND FABRICATION:

DESIGN OF SPUR GEAR

1. Select suitable materials for pinion and wheel
2. Assume pressure angle, if not given
3. Determination of minimum module
4. Find the design torque transmitted by pinion
5. Determination of minimum Centre Distance (C.D)
6. Determination of centre distance, pitch circle diameter and width of the gears
7. Determination of centre distance, pitch circle diameter and width of the gears

DESIGN OF SHAFT

1. Determine the rotational speed of shaft
2. Determine the power transmitted by shaft
3. Specify the location of bearing to support the shaft
4. Determine the magnitude of torque
5. Determine the force exerted on shaft
 - GEAR CAST IRON
 - BEARING CHROME STEEL
 - CHAIN DRIVE STEEL
 - SPROCKET A3 STEEL

MATERIALS USED:

- GEAR - CAST IRON
- SHAFTS - STAINLESS STEEL

SPECIFICATION OF CARBON STEEL FROM DATA BOOK:

- DENSITY – 7.87 g/cc
- ULTIMATE TENSILE STRENGTH – 540mpa
- YIELD STRENGTH(TENSILE) – 450mpa
- MODULUS OF ELASTICITY – 200mpa
- BULK MODULUS – 140gpa
- POISSONS RATIO – 0.29
- SHEAR MODULUS – 80gpa
- HARDNESS – 84

WORKING:

The engine drives provides the power to the gear box and the gear gives out the power to the rear wheel in two direction .when output in clockwise direction the vehicle move forward and when the output is in counter clockwise direction vehicle moves backward.

Thus reversing of the vehicle can be achieved. When the second gear on the main shaft meshes with the gear of intermediate shaft which in turn meshed with the gear of counter shaft . When the engine drive provides the power to the gear box, therefore the output shaft rotates in clockwise direction giving forward motion to the vehicle. To get the reverse motion , with the help of lever. The gear on counter shaft is slided towards another gear of main shaft. When it meshes with that gear ,the output shaft rotates in clockwise direction to move vehicle backward. So that the reversing of the vehicle can be achieved.

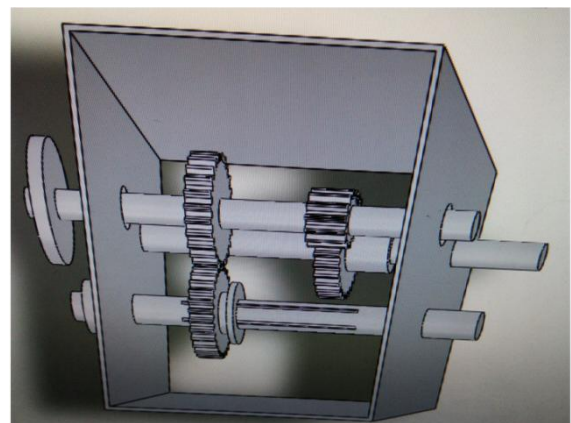

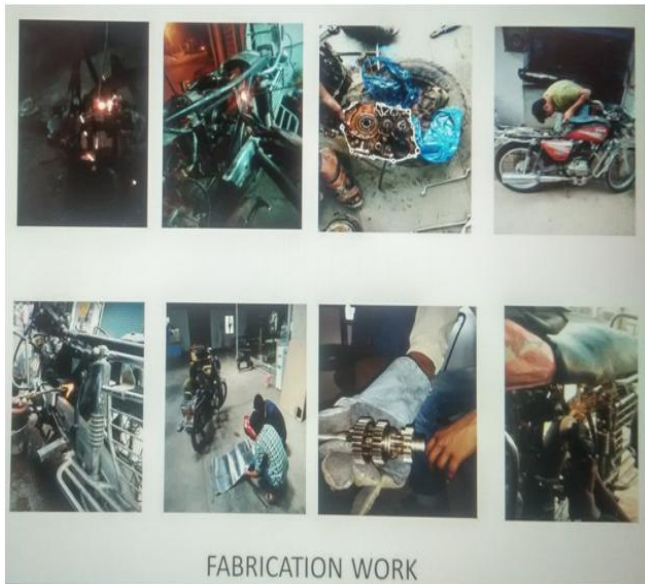

perceived cost of maintaining the dependent people and to find effective ways of ensuring the people to contribute in all spheres of life activities. Measuring the developments which are happened in automobile technology is incredibly difficult. So through this project work, we interlink these two things and try to solve the problem as more as efficient with our knowledge. We hope that the launching of our vehicle in our Indian road ways would give a pleasurable development to physical challengers which may result in unity.

ADVANTAGE:

- It improves the safety.
- It is more comfortable to the physically disabled person.
- It gives more confident to handicapped people to drive the vehicle.
- Easy to U turn the vehicle.
- Easy to reverse the vehicle.

APPLICATION:

- It is used to eliminate the partiality and complexity nature over the handicap peoples from the society.
- It is used to improve the tendency and ability of challengers to live with confidence and without considering the illness and disability of them.
- It is used to get back the hopeful of handicap to show the strength of them to society.

CONCLUSION:

A disability is a condition or function judged to be significantly imparted differentiation of an individual from the group. Current issues and debates surrounding disability include social rights and citizenship of them. In the developed countries the debate has moved beyond a concern about the