

Design and Implementation of Portable Pick and Place Robotic ARM

Ramesh Pappu

Department of Mechanical Engineering,
Hyderabad Institute of Technology and Management.

Siva Nagarjuna

Department of Mechanical Engineering,
Hyderabad Institute of Technology and Management.

R Sai Kumar

Department of Mechanical Engineering,
Hyderabad Institute of Technology and Management.

Raj Kiran

Department of Mechanical Engineering,
Hyderabad Institute of Technology and Management.

V. Venkata Phani Babu

Department of Mechanical Engineering,
Hyderabad Institute of Technology and Management.

Abstract:

Articulated link/joint movement is a primary factor for a robotic arm for its positioning and for its movement. This project deals with design and implementation of a Articulated robotic arm with a mobile platform. The joint movements were configured by Servo motors for shoulder, elbow and wrist (all comprising 3 DOF). Gripper adds another vertical axes movement (1 DOF). Movable platform deals with 2 DOF (1 DOF deals with wheel z-axes movement and another 1 DOF for change in body orientation while turning). This 5 DOF mobile articulated robotic platform serves a great purpose in various ways for humanity and in industry. Real time controlling is a major constraint in achieving prior tasks like robot movement, gripping an object and lifting it, as well handling the object with care.

The current research approach deals with Mathematical modeling, i.e. study of kinematic modeling (both forward and inverse kinematics) and defining a dynamic work envelope for the robot with its practical implementation.

Design modeling and analysis is achieved using CATIA. FEA analysis is achieved using ANSYS workbench. Kinematic problem is achieved using RoboAnalyzer software and Real time Control is achieved by IOT device NodeMCU with Arduino IDE.

1. INTRODUCTION

The field of robotics has its origins in science fictions. The word robot comes from the Czech word "robota" means forced labor in 1920. It took another 40 years before the modern technology of industrial robotics began. Today, robots are highly automated mechanical manipulators controlled by computers. A robot may appear like a human being or an animal or a simple electro-mechanical device. A robot may act under the direct control of a human (e.g. the robotic arm of the space shuttle) or autonomously under the control of a programmed computer. Robots may be used to perform tasks that are too dangerous or difficult for humans to implement directly (e.g. nuclear waste cleanup) or may be used to automate repetitive tasks that can be performed more cheaply by a robot than by the employment of a human (e.g. automobile production) or may be used to automate mindless repetitive tasks that should be performed with more precision by a robot than by a human (material handling, material transfer applications, machine loading and unloading, processing operations, assembly and inspection).[4]

The last two decades have witnessed a significant advance in the field of robots application. Many more applications are expected to appear in space exploration, battlefield and in various actives of daily life in the coming years. A robot is a mechanical device that performs automated tasks and movements,

according to either pre-defined program or a set of general guidelines and direct human supervision.

These tasks either replace or enhance human work, such as in manufacturing, contraction or manipulation of heavy or hazardous material. Robot is an integral part in automating the flexible manufacturing system that one greatly in demand these days. Robots are now more than a machine, as robots have become the solution of the future as cost labor wages and customers demand. Even though the cost of acquiring robotic system is quite expensive but as today's rapid development and a very high demand in quality with ISO standards, human are no longer capable of such demands. Research and development of future robots is moving at a very rapid pace due to the constantly improving and upgrading of the quality standards of products.[3]

1.1 PROBLEM STATEMENT:

To solve the problems of pick and place the cylindrical object having 3 cm diameter and 150 gram weight from one position to any position to another at room temperature in order to reduce human efforts and efficient material handling.

2. DESIGN OF ROBOTIC ARM

The mechanical construction in this project is to build and assemble the robotic arm body. After giving a thorough consideration of all the preceding works in this field, a three degree of freedom manipulator having variable programmed motions to carry out variety of tasks in diverse environments is chosen.

This is a three axis articulate manipulator designed to move material like machine parts, tools, specialized devices, etc Movable platform deals with 2 DOF. It is driven by four servomotors and has a gripper as end-effectors and two 100 rpm motors for the base cart. The gripper has fingers grasping and manipulation of objects as big as a 150 ml cylindrical bottle and having a weight of about 150 gm throughout the arm's workspace.

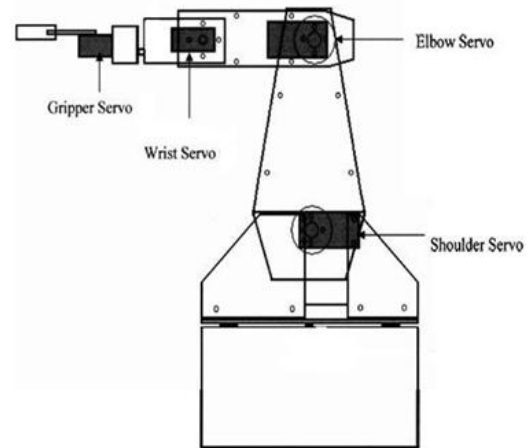

Figure 1: Design Overview of Robotic Arm.

2.1 DESIGN CONSIDERATION:

The following were put into consideration in the design process.

- i. Electrical actuators DC servo are chosen instead of hydraulic and pneumatic actuators because of the little power requirement and its light weight which is suitable for this design.
- ii. Materials used for the fabrication are polymethylmethacrylate PMMA.
- iii. The materials which will be used for the design will be light in weight so as to reduce the weight concentration on the base and the shoulder.
- iv. Rectangular sheets instead of blocks are chosen for the links because of their light weight and stability and to reduce the weight of the arm.
- v. A continuous path controller was chosen (NodeMCU IOT device).
- vi. The torque is fully balanced by the inertia of the electric motor

2.2 SELECTION OF DEGREE OF FREEDOM (DOF):

The number of independent movements that an object can perform in 3D space is termed as the number of degree of freedom (DOF). Thus, a rigid body free in space has six degree of freedom – three for positions and three for orientations. For our application 3 DOF are suitable and movable platform deals with 2 DOF.

2.3 MATERIAL SELECTION:

The most suitable material to fabricate the structure of the arm has to be light and strong. Otherwise, the servo motor will not be able to pull up the arm and to perform the desired turning degree. Among the materials that can be considered to fabricate the structure are aluminium, PMMA, Perspex, plastic polymer and carbon fiber. In choosing the fabrication materials, the aspect of availability of the materials, the overall cost and the flexibility to be shaped, should also be taken into consideration. Thus among the four materials considered, the Acrylic Sheet (PMMA) is the most ideal material to be chosen as fabrication material.

2.4 SPECIFICATIONS OF ROBOTIC ARM:

The robot arm for this project is the revolute type that closely resembles the human arm. Shoulder that mounted on base can move the arm through 180 degrees, from horizontal to vertical on each side. The shoulder uses large-scale servo, provide the torque needed to lift the rest of the arm, as well as any object that it may be grasping. Attached to the shoulder piece is an elbow that can move through 180 degrees, also powered by a large-scale servo. The wrist is made up of one standard servo and can move through 180 degrees, in vertical direction. Attached to the wrist is a two-fingered gripper that utilizes a unique design built around a single standard servo.

Table no. 4.6: Specification of robotic arm.

Specification	Value
Number of axes	3 + 2(cart)
Horizontal reach	310
Vertical reach	310
Drives	4 servo motors, 2Micro (9kgf), 2 Std (12Kgf)
Configuration	3 Axes plus gripper plus cart. All axes completely independent. All axes can be controlled simultaneously.
Work Envelope	(a) Shoulder Rotation -180 degrees (b) Elbow Rotation - 300 degrees (c) Wrist Rotation -180 degrees (d) Gripper Rotation -90 degrees

3. CAD MODELLING OF ROBOTIC ARM

Considering the all points in designing, CAD model (CATIA V5 R20 software) is used for robotic arm design. Various component of robotic arm is shoulder, elbow, wrist, grippers. The purpose of utilizing this CATIA V5 software is because CATIA V5 can provide a detail, real images and walk through overviews for demonstrating design. The 3D views of various parts of robotic arm are shown in figure.

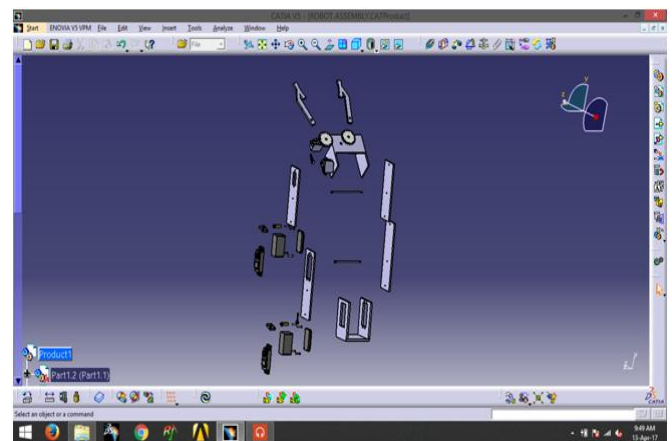
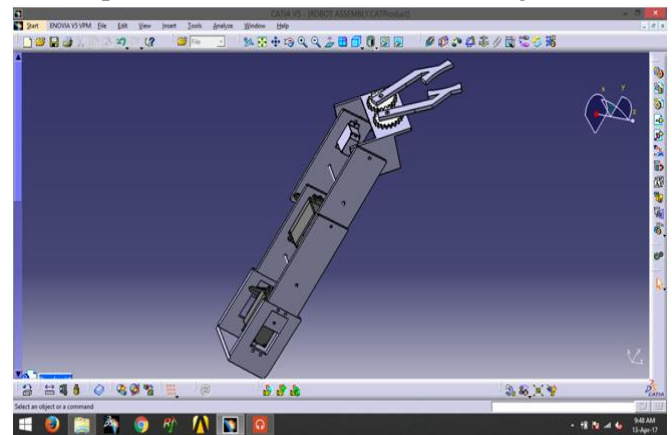

4. INVERSE KINEMATICS ANALYSIS

In order to control the position and orientation of end-effector of a robot arm to reach its object, the inverse kinematics solution is more important. In this project, inverse kinematics problem is solved by RoboAnalyzer 3D Model Based Robotics Learning Software. RoboAnalyzer is developed in the Mechatronics Lab, Department of Mechanical Engineering at IIT Delhi, India under the guidance of Prof. S. K. Saha.

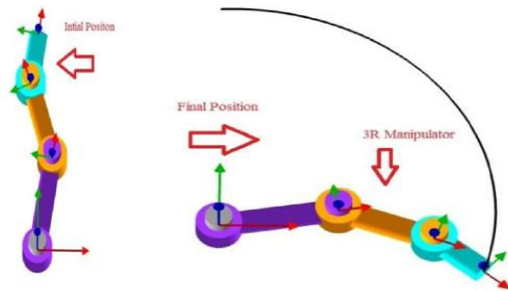

Figure 2: Initial and final position of Robotic arm.

The position and orientation of the end-effector in terms of given joint angles is calculated using a set of equations and this is forward kinematics. This set of equations is formed using DH parameters obtained from the link coordinate frame assignation. The parameters for the manipulator are listed in Table 4.5.1, where is the rotation about the Z-axis, α rotation about the X-axis, d transition along the Z-axis, and transition along the X-axis

Table 2: DH kinematic parameter table

Axis	Type	Joint angle θ in degree	Link length d, in m	Joint Offset a, in m	Twist angle α , in radian
1	Shoulder	θ_1	0.13	0	0
2	Elbow	θ_2	0.11	0	0
3	Base	θ_3	0.07	0	0

Giving these information to RoboAnalyze Software for finding the joint angle (θ) for different positions of robotic arm. Following results are obtained:

Table 3: Joint angles for different positions of end effector

Sr. No.	Positions	in case 1	in Case 2
1	X = 0.23 Y = 0.02	1 = -35.59	1 = 49.84
		2 = 96.02	2 = -96.02
		3 = -60.42	3 = 46.17
2	X = 0.08 Y = 0.08	1 = 25.49	1 = 140.25
		2 = 141.87	2 = -141.87
		3 = -167.37	3 = 1.62
3	X = 0.12 Y = 0.12	1 = 17.32	1 = 117.43
		2 = 115.0	2 = -115.0
		3 = -132.35	3 = -2.40
4	X = 0.17 Y = 0.19	1 = 37.99	1 = 86.48
		2 = 53.28	2 = -53.28
		3 = -91.27	3 = -33.20
5	X = 0.02 Y = 0.23	1 = 91.90	1 = 112.61
		2 = 22.61	2 = -22.61
		3 = -114.52	3 = -90.00

Where case 1 and case 2 are two different trajectory of robotic arm which is suitable for our project application. We can select any one of them. Some Graphs output come out from RoboAnalyze Software by providing initial positions and final positions in term of joint angle as below:

5. FE ANALYSIS

Ansys software uses the displacement formulation of the finite element method to calculate component displacements, strains, and stresses under internal and external loads. The geometry under analysis is discretized using tetrahedral (3D), triangular (2D), and beam elements, and solved by either a direct sparse or iterative solver.. Ansys Software can use either an h or p adaptive element type, providing a great advantage to designers and engineers as the adaptive method ensures that the solution has converged.

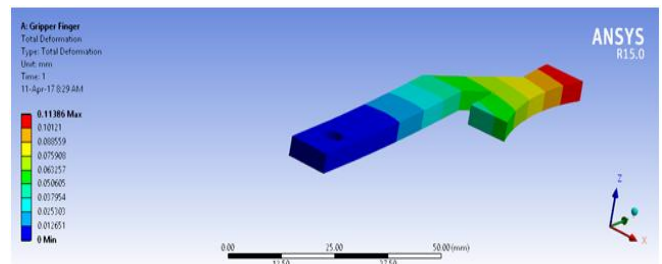

Grippers Analysis (Total Deformation)

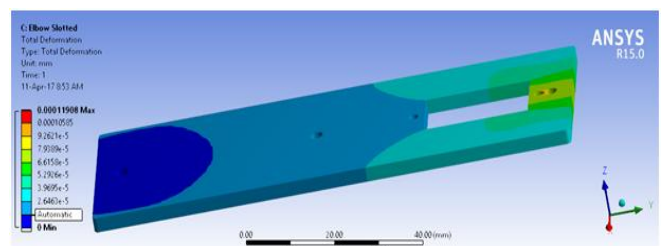

Elbow Analysis (Total Deformation)

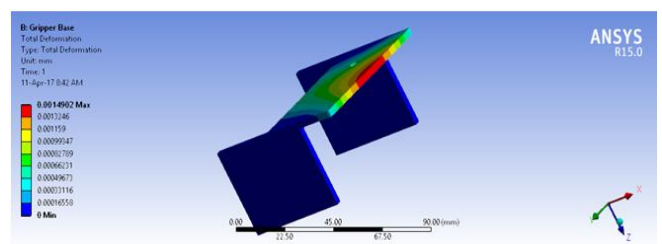

Gripper Analysis (Total Deformation)

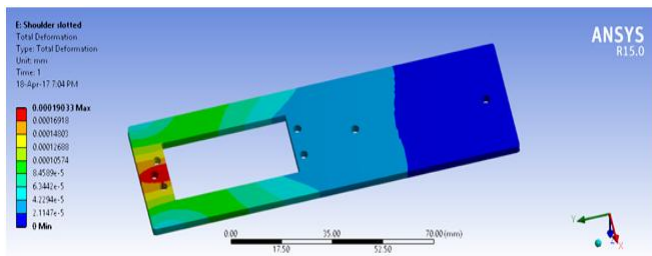

Shoulder Analysis (Total Deformation)

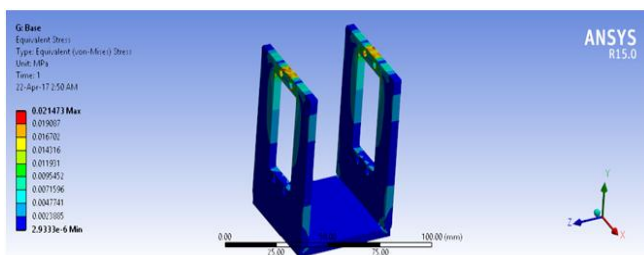

Base Analysis (Equivalent Stress)

CONCLUSION

In this project we have designed and fabricated a 3-DOF Portable manipulator which has been successfully completed. With reference to many available manipulators and mobile platforms in market, a practical design for the manipulator has been perceived and computer aided designing tools like CATIA V5 is used to model the desired manipulator. Theoretical analysis of the inverse kinematics was carried out to determine the end effectors position and orientation using Robo Analyzer. FE Analysis is done by using ansys software and control is done using IOT.