

## An Advanced Multilevel Inverter Based Dstatcom with Improved Efficiency



**G. D. Shingade**  
M.Tech Student  
Department of EPS  
BRIL



**R Nagesh**  
Assistant Professor  
Department of EPS  
BRIL

### ABSTRACT

*This paper presents an investigation of five-Level Cascaded H – bridge (CHB) Inverter as Distribution Static Compensator (DSTATCOM) in Power System (PS) for compensation of reactive power and harmonics. The advantages of CHB inverter are low harmonic distortion, reduced number of switches and suppression of switching losses. The DSTATCOM helps to improve the power factor and eliminate the Total Harmonics Distortion (THD) drawn from a Non-Liner Diode Rectifier Load (NLDRL). The D-Q reference frame theory is used to generate the reference compensating currents for DSTATCOM while Proportional and Integral (PI) control is used for capacitor dc voltage regulation. A CHB Inverter is considered for shunt compensation. we are using Sinusoidal Pulse Width Modulation (SPWM) technique. The results are obtained through Mat lab / Simulink.*

**INDEX TERMS:** DSTATCOM, (SPWM), CHB multilevel inverter.

### 1. INTRODUCTION

Demand for high-voltage, high power converters capable of producing high-quality waveforms while utilizing low voltage devices and reduced switching frequencies has led to the multilevel inverter development with regard to semiconductor power switch voltage limits. Multilevel inverters include an array of power semiconductors and capacitor voltage sources, the output of which generate voltages with

stepped waveforms. The commutation of the switches permits the addition of the capacitor voltages, which reach high voltage at the output, while the power semiconductors must withstand only reduced voltages. The most attractive features of multilevel inverters are as follows:-

- 1) They can generate output voltages with extremely low distortion and lower  $dv/dt$ .
- 2) They draw input current with very low distortion.
- 3) They generate smaller common mode (CM) voltage, thus reducing the stress in the motor bearings. In addition, using sophisticated modulation methods, CM voltages can be eliminated.
- 4) They can operate with a lower switching frequency.

The multilevel inverter has been implemented in various applications ranging from medium to high-power levels, such as motor drives, power conditioning devices, also conventional or renewable energy generation and distribution.

The different multilevel inverter structures are cascaded H-bridge, diode clamped and flying capacitor multilevel inverter [4]. Among the three topologies, the cascaded multilevel inverter has the potential to be the most reliable and achieve the best fault tolerance owing to its modularity, a feature that enables the inverter to continue operating at lower power levels after cell failure. Modularity also permits the cascaded multilevel inverter to be stacked easily for high power and high-voltage applications. The cascaded multilevel

inverter typically comprises several identical single phase H-bridge cells cascaded in series at its output side.

Many techniques have been proposed to improve the supply side power factor to cancel out the harmonics generated by power electronic loads. The remedies to PQ problems are reported in the literature and are known by the generic name of custom power devices (CPD) [4]. The DSTATCOM (Distribution static compensator) is a shunt-connected CPD, with the load which takes care of the compensation of reactive power and unbalance loading in the DS (i.e PQ problems). Similarly, the application of Cascaded H-Bridge (CHB) Multilevel Voltage source converter with split capacitors for three-phase three-wire system is found to be satisfactory [6-12]. Among the different control techniques applied to three-phase three-wire compensators, the SRFT (synchronous reference frame theory) based technique is found to be suitable for the control of DSTATCOM[14].

**II. PROPOSED SYSTEM DESIGN OF MULTILEVEL BASED DSTATCOM**

**A. Principle of DSTATCOM**

A D-STATCOM (DistributionStatic Compensator), which is schematically depicted in Figure-1, consists of a two-level Voltage Source Converter (VSC), a dc energy storage device, a coupling transformer connected in shunt to the distribution network through a coupling transformer. The VSC converts the dc voltage across the storage device into a set of three-phase ac output voltages. These voltages are in phase and coupled with the ac system through the reactance of the coupling transformer. Suitable adjustment of the phase and magnitude of the D-STATCOM output voltages allows effective control of active and reactive power exchanges between the DSTATCOM and the ac system. Such configuration allows the device to absorb or generate controllable active and reactive power

The VSC connected in shunt with the ac system provides a multifunctional topology which can be used for up to three quite distinct purposes:

1. Voltage regulation and compensation of reactive power;
2. Correction of power factor
3. Elimination of current harmonics.

**FIVE LEVEL CASCADED H-BRIDGE MULTILEVEL INVERTER**

**cascaded H-bridge multilevel inverter**

Fig.1 shows a five level cascaded H-bridge multilevel inverter. The converter consists of two series connected H-bridge cells which are fed by independent voltage sources. The outputs of the H-bridge cells are connected in series such that the synthesized voltage waveform is the sum of all of the individual cell outputs. The main advantages of cascaded H-bridge inverter is that it requires least number of components, modularized circuit and soft switching can be employed. But the main disadvantage is that when the voltage level increases, the number of switches increases and also the soures, this in effect increases the cost and weight. The cascaded H-bridge multilevel inverters have been applied where high power and power quality are essential, for example, static synchronous compensators, active filter and reactive power compensation applications, photo voltaic power conversion, uninterruptible power supplies, and magnetic resonance imaging. Furthermore, one of the growing applications for multilevel motor drive is electric and hybrid power trains.

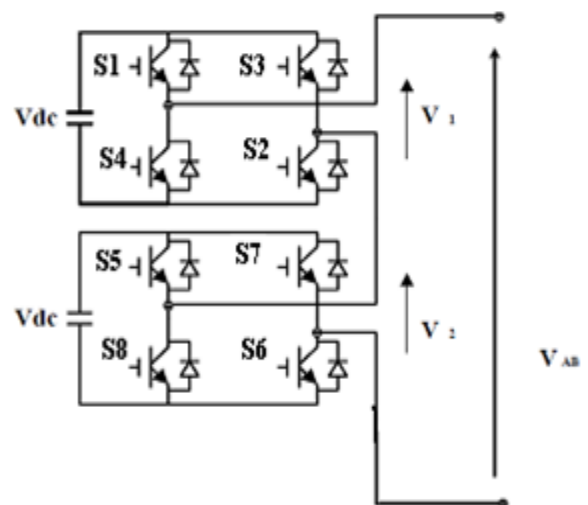

Fig 1. Five level cascaded H-bridge multilevel inverter

Table-1:- Switching table for 5-level CHB Inverter

Switches Turn On	Voltage Level
S1, S2	Vdc
S1,S2,S5,S6	2Vdc
S4,D2,S8,D6	0
S3,S4	-Vdc
S3,S4,S7,S8	-2Vdc

### III. CONTROL STRATEGY SINUSOIDAL PULSE WIDTH MODULATIONTECHNIQUE

This is a very simple technique for harmonic reduction. In this technique pulse magnitude will be constant and only pulse time (width) can be changed. In this pure sine wave is compared with carrier (triangular) wave and producing gate pulses. Sine wave has fundamental frequency and carrier wave can be taken more than fundamental frequency. Sinusoidal pulse width modulation is one of the primitive techniques, which are used to suppress harmonics presented in the quasi-square wave. In the modulation techniques, there are two important defined parameters: 1) the ratio  $P = \omega_c / \omega_m$  known as frequency ratio, 2) the ratio  $M_a = A_m / A_c$  known as modulation index, where  $\omega_c$  is the reference frequency,  $\omega_m$  is the carrier frequency,  $A_m$  is reference signal amplitude and  $A_c$  is carrier signal amplitude.

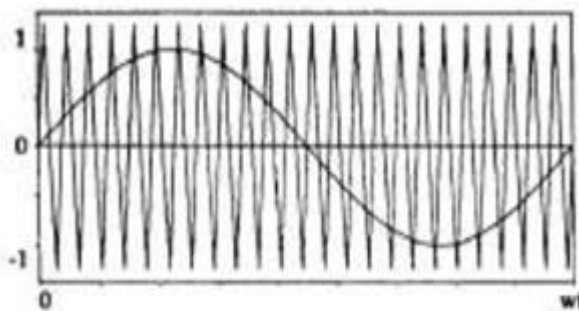

Fig.2 sinusoidal pulse width modulation

### IV. SIMULATION RESULTS

#### Simulation Circuit:

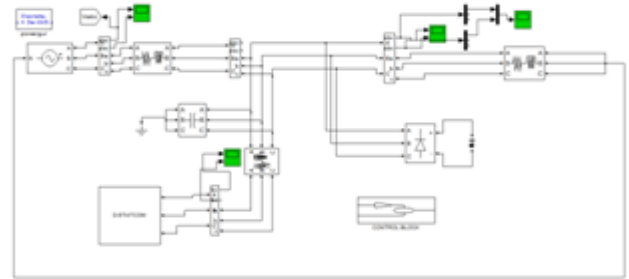

Fig.5. Matlab Simulation Circuit

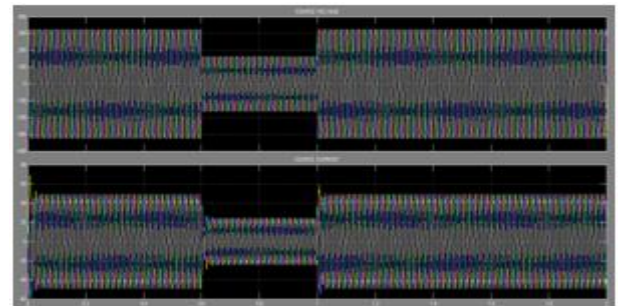

Fig.6 voltage source.

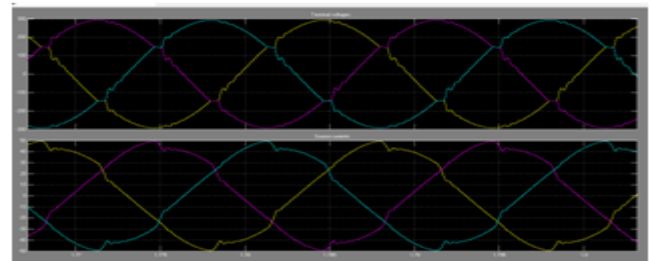

Fig.7 Before compensation. (a) Terminal voltages. b) Source currents.

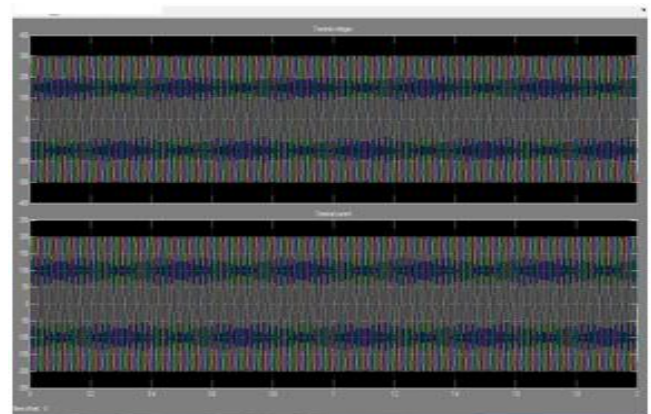

Fig.8 Terminal voltages.



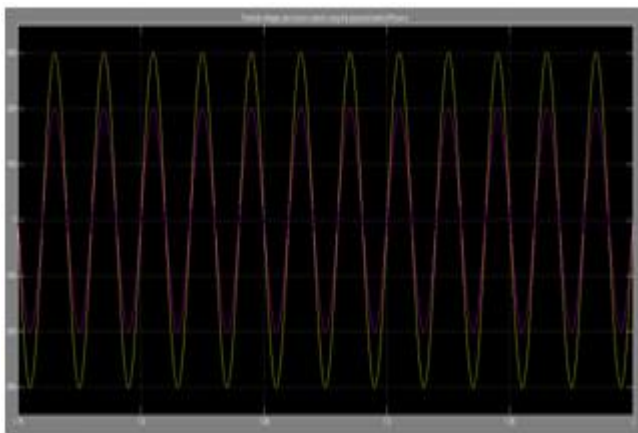

Fig.9 Terminal voltages and source currents using the proposed method. Phase-a

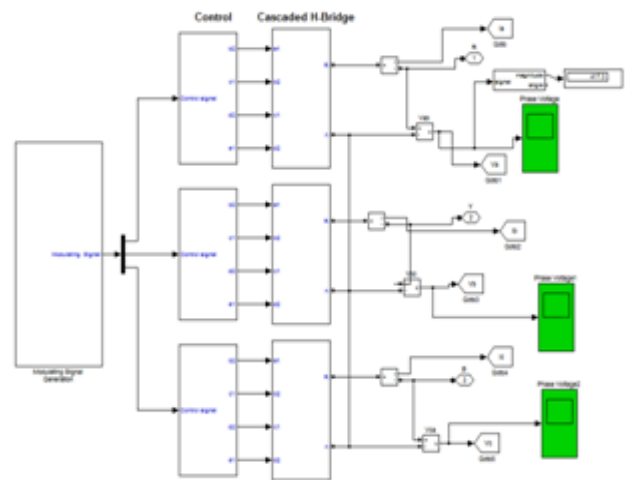

Fig.12 .Multilevel statcom circuit

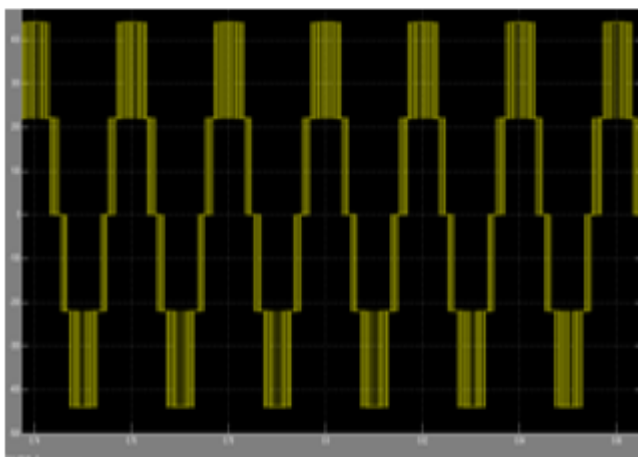

Fig.10. Phase 5 level output voltage of multilevel inverter

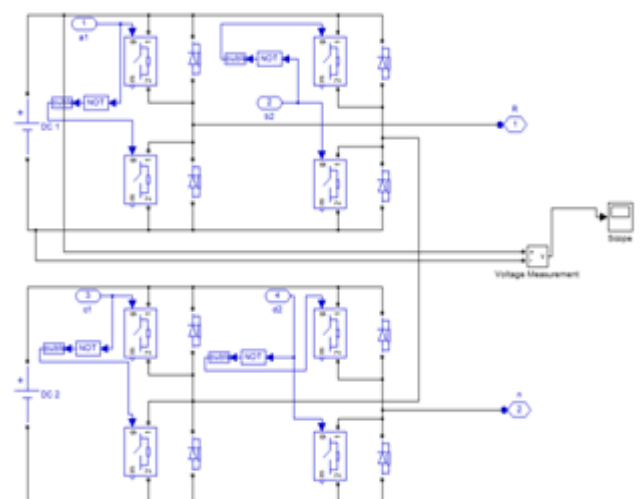

Fig.13. Cascaded H-bridge circuit

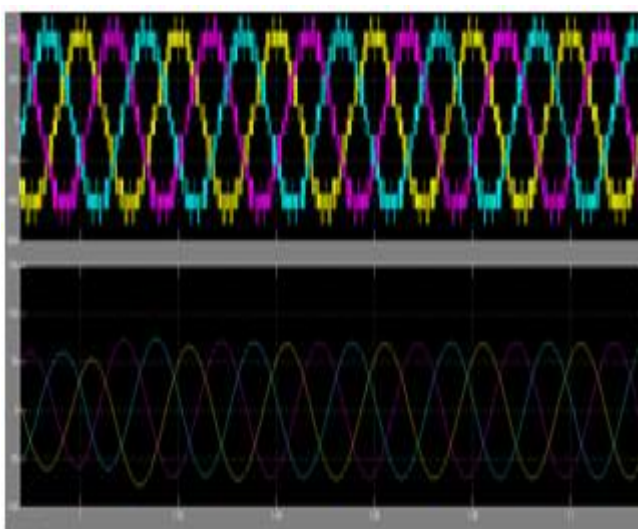

Fig.11. Multilevel inverter output voltage & current

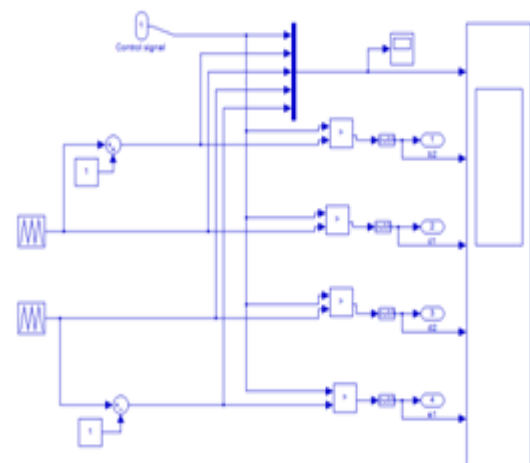

Fig.14. Control Block

## V.CONCLUSION

A DSTATCOM with five level CHB inverter is investigated. Mathematical model for single H-Bridge inverter is developed which can be extended to multi H-Bridge. The source voltage, load voltage, source current, load current, power factor simulation results under non-linear loads are tabulated. Finally with the help of Matlab/Simulink based model simulation we conclude that the results are presented.

## REFERENCES

- [1] *IEEE Recommended Practices and Requirements for Harmonics Control in Electric Power Systems*, IEEE Std. 519, 1992.
- [2] A. Moreno-Munoz, *Power Quality: Mitigation Technologies in a Distributed Environment*. London, U.K.: Springer-Verlag, 2007.
- [3] N. G. Hingorani, "Introducing Custom Power," *IEEE Spectrum*, Vol.32, n. 6, pp. 41-48, June 1995
- [4] Ghosh and G. Ledwich, *Power quality enhancement using custom power devices*, London, Kluwer Academic Publishers, 2002.
- [5] Acha, V.G. Agelidis, O. Anaya-Lara and T.J.E.Miller, *Power Electronic Control in Electrical systems*, England, Newnes, 2002.
- [6] A Pandey, B Singh, B N Singh, A Chandra, K Al-Haddad, D P Kothari, "A Review of Multilevel Power Converters", *IE (I) Journal.EL*, vol. 86, pp.220-231, March, 2006.
- [7] K.A Corzine, and Y.L Familant, "A New Cascaded Multi-level H-Bridge Drive," *IEEE Trans. Power.Electron.*, vol.17, no.1, pp.125-131. Jan 2002.
- [8] J.S.Lai, and F.Z.Peng "Multilevel converters – A new breed of converters", *IEEE Trans. Ind.Appli.*, vol.32, no.3, pp.509-517. May/ Jun. 1996.
- [9] T.A.Maynard, M.Fadel and N.Aouda, "Modelling of multilevel converter," *IEEE Trans. Ind.Electron.*, vol.44, pp.356-364. Jun.1997.
- [10] P.Bhagwat, and V.R.Stefanovic, "Generalized structure of a multilevel PWM Inverter," *IEEE Trans. Ind. Appln*, Vol.1A-19, no.6, pp.1057-1069, Nov./Dec..1983.

## AUTHOR DETAILS:

**G. D. Shingade:** Obtained B.E in Electrical Engineering from M.B.E.S. C.O.E. Ambajogai, Maharashtra, India in 2012. Currently, He is pursuing M. Tech in Electrical-PS from Brilliant Grammar School Educational Society's Group of Institutions Integrated campus, Hyderabad, Telangana His area of interest include Network Analysis, Power system analysis, Power Electronics, Power system, Power Quality, Extra High Voltage Engineering, Electrical Drives.

**R. Nagesh:** Working as a assistant professor & head of the department in brilliant group of technical institutions. recieved the B.Tech degree in Electrical and Electronics Engineering from Vignan Institute of Technology & science, in 2010 and recieved M.Tech degree in Power Electronics from Auroras Engineering College, Bhongir. He is interested in FACTS devices and their applications & power electronics.