

A Noble Design of Battery Converter for Grid Integrated Solar Energy

T.Sripal Reddy, M.Tech, Ph.D

Associate professor & HOD,
Department of EEE,

Sarada Institute of Technology &
Sciences, Ragunadhpallem, Khammam.

G.Ravi, M.Tech

Associate professor,
Department of EEE,

Sarada Institute of Technology &
Sciences, Ragunadhpallem, Khammam.

Nimmala Soumya Sri

Power Electronics,

Sarada Institute of Technology &
Sciences, Ragunadhpallem,
Khammam.

Abstract:

The main concept of the new converter is to use a Single-stage three phase grid ties - solar PV converter to perform dc/dc and dc/ac operations. This converter solution is appealing for PV- battery applications, because it minimizes the number of conversion stages, improving efficiency and reducing cost, weight and volume.

This converter solution is appealing for PV-battery application, because it minimizes the number of conversion stages, thereby improving efficiency and reducing cost, weight, and volume. In this paper, a combination of analysis and experimental tests is used to demonstrate the attractive performance characteristics of the proposed RSC.

Keywords:

Converter, Energy Storage, Photovoltaic (PV), Solar.

I.INTRODUCTION:

SOLAR photovoltaic (PV) electricity generation is not available and sometimes less available depending on the time of the day and the weather conditions. Solar PV electricity output is also highly sensitive to shading. When even a small portion of a cell, module, or array is shaded, while the remainder is in sunlight, the output falls dramatically.

Therefore, solar PV electricity output significantly varies. From an energy source standpoint, a stable energy source and an energy source that can be dispatched at the request are desired. As a result, energy storage such as batteries and fuel cells for solar PV systems has drawn significant attention and the demand of energy storage for solar PV systems

has been dramatically increased, since, with energy storage, a solar PV system becomes a stable energy source and it can be dispatched at the request, which results in improving the performance and the value of solar PV systems. There are different options for integrating energy storage into a utility-scale solar PV system. Specifically, energy storage can be integrated into the either ac or dc side of the solar PV power conversion systems which may consist of multiple conversion stages.

Every integration solution has its advantages and disadvantages. Different integration solutions can be compared with regard to the number of power stages, efficiency, storage system flexibility, control complexity, etc. This paper introduces a novel single-stage solar converter called reconfigurable solar converter (RSC). The basic concept of the RSC is to use a single power conversion system to perform different operation modes such as PV to grid (dc to ac),

PV to battery (dc to dc), battery to grid (dc to ac), and battery/PV to grid (dc to ac) for solar PV systems with energy storage. The RSC concept arose from the fact that energy storage integration for utility-scale solar PV systems makes sense if there is an enough gap or a minimal overlap between the PV energy storage and release time.

In case (a), the PV energy is always delivered to the grid and there is basically no need of energy storage. However, for cases (b) and (c), the PV energy should be first stored in the battery and then the battery or both battery and PV supply the load. In cases (b) and (c), integration of the battery has the highest value and the RSC provides significant benefit over other integration options when there is the time gap between generation and consumption of power.

Reconfigurable solar converter:

The schematic of the proposed RSC is presented in Fig. 1. The RSC has some modifications to the conventional three-phase PV inverter system. These modifications allow the RSC to include the charging function in the conventional three-phase PV inverter system.

Assuming that the conventional utility-scale PV inverter system consists of a three-phase voltage source converter and its associated components, the RSC requires additional cables and mechanical switches, as shown in Fig. 1. Optional inductors are included if the ac filter inductance is not enough for the charging purpose.

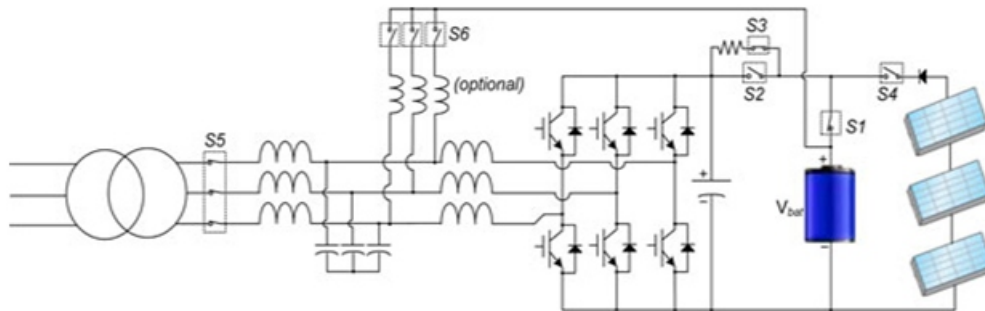

Fig. 2: Schematic of the proposed RSC circuit

Modes of operation:

In Mode 1, the PV is directly connected to the grid through a dc/ac operation of the converter with possibility of maximum power point tracking (MPPT) control and the S1 and S6 switches remain open. In Mode 2, the battery is charged with the PV panels through the dc/dc operation of the converter by closing the S6 switch and opening the S5 switch. In this mode, the MPPT function is performed; therefore, maximum power is generated from PV. There is another mode that both the PV and battery provide the power to the grid by closing the S1 switch. This operation is shown as Mode 3. In this mode, the dc-link voltage that is the same as the PV voltage is enforced by the battery voltage; therefore, MPPT control is not possible. Mode 4 represents an operation mode that the energy stored in the battery is delivered to the grid. There is another mode, Mode 5 that the battery is charged from the grid.

The technical and financial benefits that the RSC solution is able to provide are more apparent in larger solar PV power plants. Specifically, a large solar PV power plant using the RSC can be controlled more effectively and its power can be dispatched more economically because of the flexibility of operation. Developing a detailed operation characteristic of a solar PV power plant with the RSC is beyond the scope of this paper. However, different system controls as shown in Fig. 5 can be proposed based on the requested power from the grid operator P_{req} and available generated power from the plant P_{gen} .

These two values being results of an optimization problem (such as unit commitment methods) serve as variables to control the solar PV power plant accordingly.

II. CONTROL STRATEGY:

DC/AC Operation:

The dc/ac operation of the RSC is utilized for delivering power from PV to grid, battery to grid, PV and battery to grid, and grid to battery. The RSC performs the MPPT algorithm to deliver maximum power from the PV to the grid. Like the conventional PV inverter control, the RSC control is implemented in the synchronous reference frame. The synchronous reference frame proportional-integral current control is employed. In a reference frame rotating synchronously with the fundamental excitation, the fundamental excitation signals are transformed into dc signals.

As a result, the current regulator forming the innermost loop of the control system is able to regulate ac currents over a wide frequency range with high bandwidth and zero steady-state error. For the pulsewidth modulation (PWM) scheme, the conventional space vector PWM scheme is utilized. Fig. 2 presents the overall control block diagram of the RSC in the dc/ac operation. For the dc/ac operation with the battery, the RSC control should be coordinated with the battery management system (BMS), which is not shown in Fig. 2.

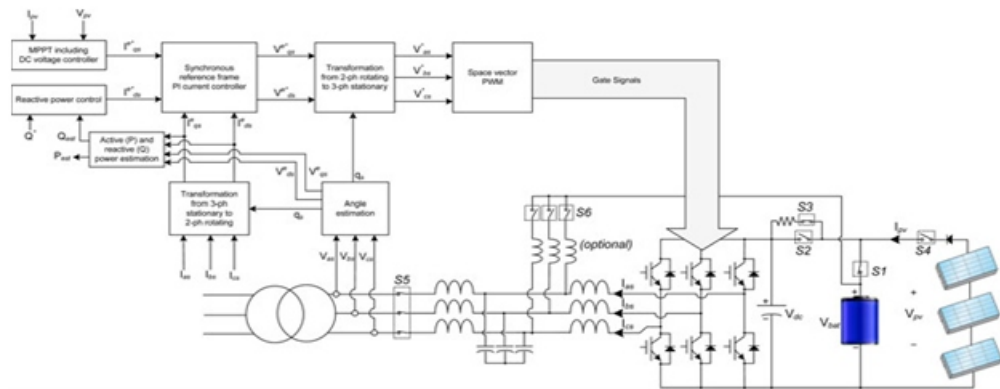

Fig. 2: Overall control block diagram of the RSC in the dc/ac operation

DC/DC Operation:

The dc/dc operation of the RSC is also utilized for delivering the maximum power from the PV to the battery. The RSC in the dc/dc operation is a boost converter that controls the current flowing into the battery. In this research, Li-ion battery has been selected for the PV-battery systems. Li-ion batteries require a constant current, constant voltage type of charging algorithm. In other words, a Li-ion battery should be charged at a set current level until it reaches its final voltage. At the final voltage, the charging process should switch over to the constant voltage mode, and provide the current necessary to hold the battery at this final voltage. Thus, the dc/dc converter performing charging process

must be capable of providing stable control for maintaining either current or voltage at a constant value, depending on the state of the battery. Typically, a few percent capacity losses happen by not performing constant voltage charging. However, it is not uncommon only to use constant current charging to simplify the charging control and process. The latter has been used to charge the battery. Therefore, from the control point of view, it is just sufficient to control only the inductor current. Like the dc/ac operation, the RSC performs the MPPT algorithm to deliver maximum power from the PV to the battery in the dc/dc operation. Fig. 3 shows the overall control block diagram of the RSC in the dc/dc operation. In this mode, the RSC control should be coordinated with the BMS, which is not shown in Fig. 3.

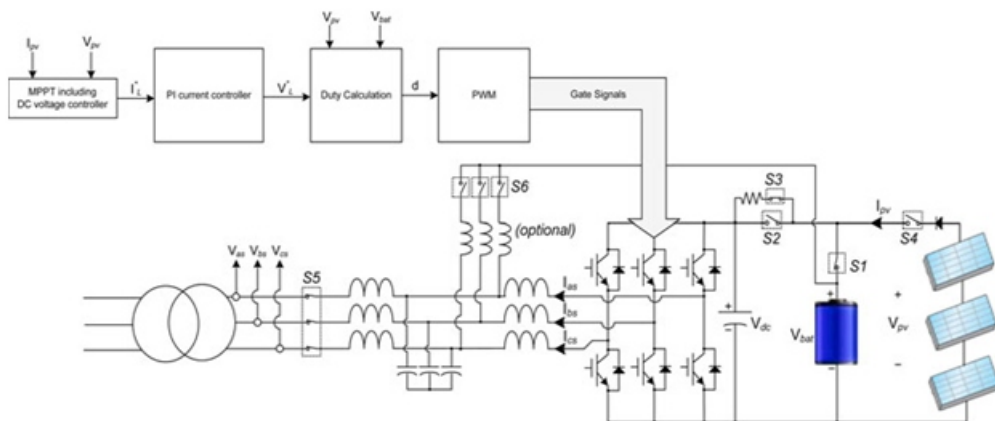

Fig. 3: Overall control block diagram of the RSC in the dc/dc operation.

III. PROPOSED CONVERTER:

One of the most important requirements of the project is that a new power conversion solution for PV-battery systems must have minimal complexity and modifications to the conventional three-phase solar PV converter system.

Therefore, it is necessary to investigate how a three-phase dc/ac converter operates as a dc/dc converter and what modifications should be made. It is common to use a LCL filter for a high-power three-phase PV converter and the RSC in the dc/dc operation is expected to use the inductors already available in the LCL filter.

There are basically two types of inductors, coupled three-phase inductor and three single-phase inductors that can be utilized in the RSC circuit. Using all three phases of the coupled three-phase inductor in the dc/dc operation causes a significant drop in the inductance value due to inductor core saturation. Table I presents an example of inductance value of a coupled three-phase inductor for the dc/dc operation, which shows significant drop in the inductance value. The reduction in inductance value requires inserting additional inductors for the dc/dc operation which has been marked as “optional” in Fig. 1.

To avoid extra inductors, only one phase can perform the dc/dc operation. However, when only one phase, for instance phase B, is utilized for the dc/dc operation with only either upper or lower three insulated-gate bipolar transistors (IGBTs) are turned OFF as complementary switching, the circulating current occurs in phases A and C through filter capacitors, the coupled inductor, and switches, resulting in significantly high current ripple in phase B current, as shown in Fig. 4.

To prevent the circulating current in the dc/dc operation, the following two solutions are proposed; 1) all unused upper and lower IGBTs must be turned OFF; 2) the coupled inductor is replaced by three single-phase inductors. While the first solution with a coupled inductor is straightforward, using three single-phase inductors makes it possible to use all three phase legs for the dc/dc operation. There are two methods to utilize all three phase legs for the dc/dc operation:

- 1) Synchronous operation; 2) interleaving operation.

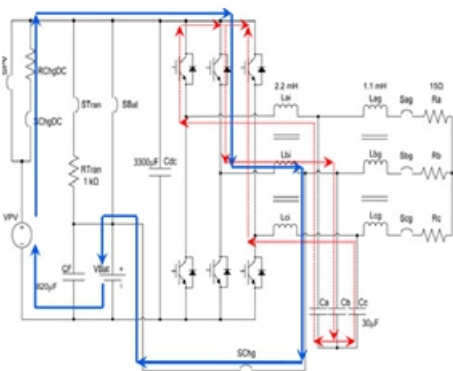

Fig. 4: Circulating current path if one phase is used for the dc/dc operation of the RSC with a coupled three-phase inductor

In the first solution, all three phase legs can operate synchronously with their own current control. In this case, the battery can be charged with a higher current compared to the case with one-phase dc/dc operation.

This leads to a faster charging time due to higher charging current capability. However, each phase operates with higher current ripples. Higher ripple current flowing into the battery and capacitor can have negative effects on the lifetime of the battery and capacitors.

IV. SIMULATION RESULTS:

The simulation circuit diagram of the RSC shown in Fig. 5 is used to verify the RSC concept experimentally. Fig. 5 shows the components used in the RSC circuit. The conventional grid-tie PV inverter is connected to the grid and delivers the power from the PV to the grid. Therefore, the conventional grid-tie PV inverter requires grid synchronization and power factor control functions.

For RSC verification, the aforementioned functions are not implemented and tested. Since the RSC uses the same algorithms for those functions as the conventional grid-tie PV inverter, it is not necessary to verify them. Therefore, the RSC circuit is connected to a passive load.

The conventional PV inverter also performs the MPPT to extract the available maximum power from the PV. For RSC verification, the MPPT is also not implemented and tested, since the RSC employs the same MPPT algorithms as the conventional PV inverter. Thus, verification of the RSC circuit is done with a controllable dc power supply, as shown in Fig. 5.

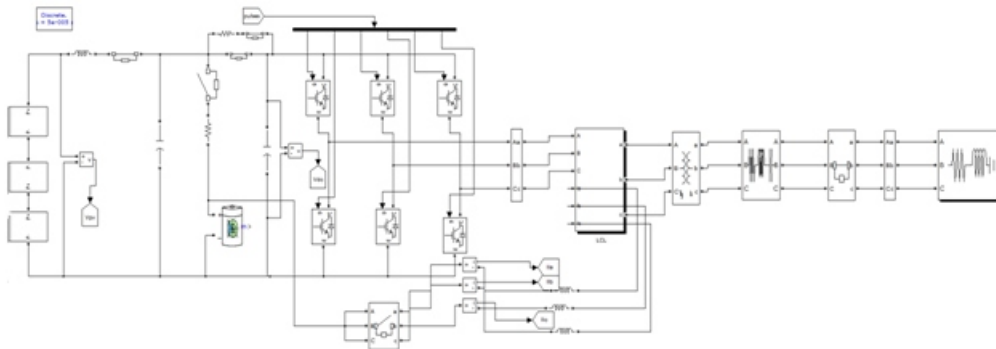

Fig 5: Simulation circuit of the proposed Converter

As shown in Fig. 14, the RSC consists of six IGBTs and diodes that have the rating of 1.2 kV and 100 A peak. There is a pre-charging circuit that limits an inrush current flowing into the capacitors of the three-phase inverter, when the dc power supply is initially connected to the three-phase inverter. The filter capacitors are used to reduce voltage and current ripples for the batteries.

There is the voltage balancing circuit that limits an inrush current flowing into the filter capacitors of the batteries, when the battery system including the battery filter capacitors is initially connected to the inverter. There are three relays used for battery charging in the dc/dc operation. The relay rating is determined by the battery charging current requirement. As mentioned earlier, a passive load is used in RSC verification. A passive load has a maximum power of 3 kW under the air-cooled condition.

At the top of the circuit is the RSC consisting of six IGBTs, six diodes, filter inductors, capacitors, relays, and wires. At the bottom of the picture is the energy storage device, the K2 Li-ion battery. The K2 battery has its own BMS. The master controls four slaves who have nine battery cells assigned. The BMS measures the state of the battery cell voltages, temperatures, and the current flowing into or out of the battery.

It also determines the battery operating status such as normal, warning, and error in which status BMS uses the relays to protect the battery system and prevent any damage. The battery system includes a pre-charging circuit to limit an inrush current flowing from the batteries into the capacitors that can be connected to the battery in parallel for a filtering purpose.

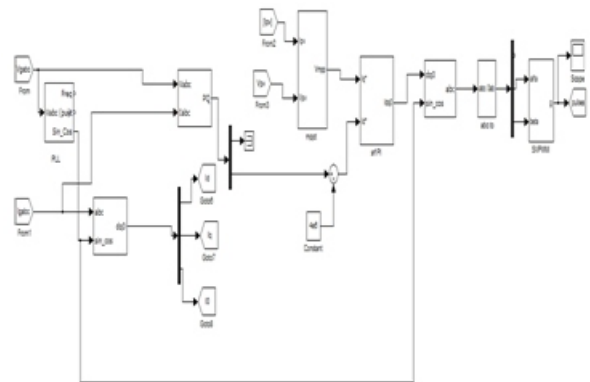

Fig 6: control circuit for dc/ac operation

Model1:

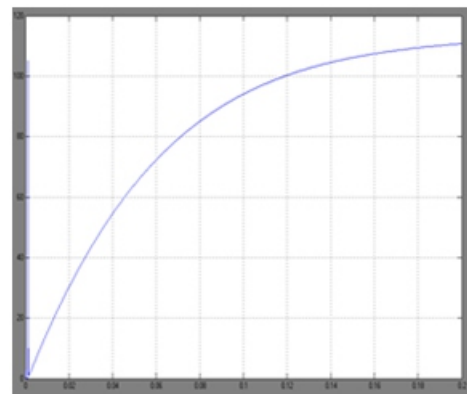

Fig 7: PV array voltage

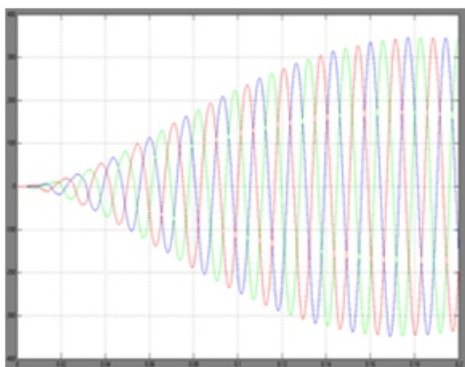

Fig 8: Grid voltage

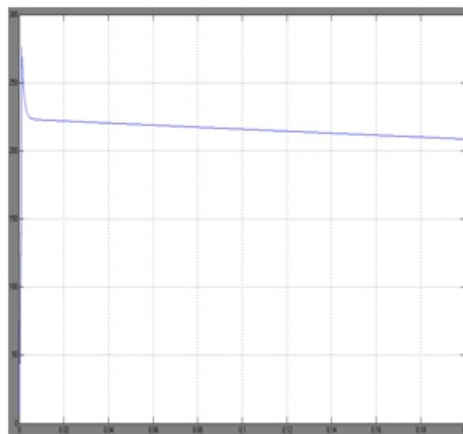

Fig 11: PV voltage

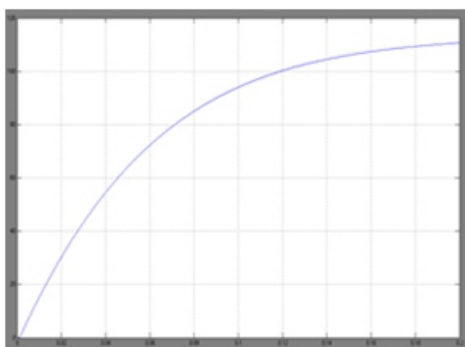

Fig9: dc voltage

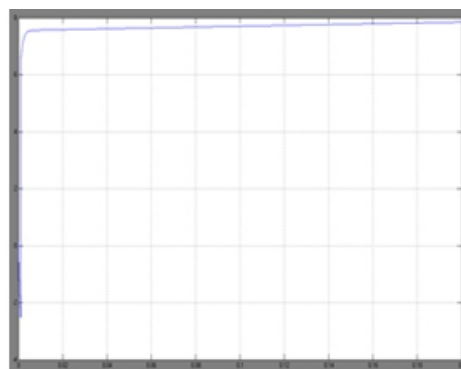

Fig 12: PV current

Mode 2:

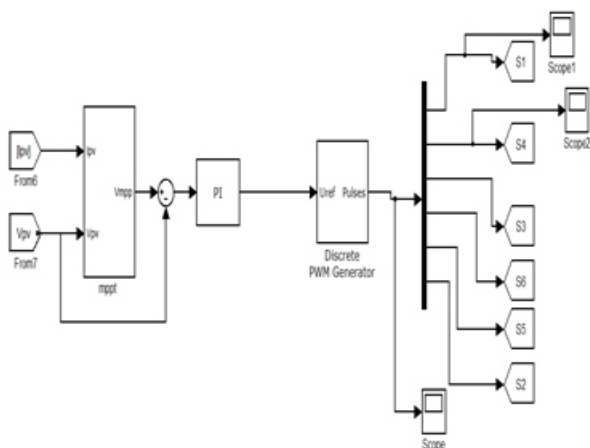

Fig 10: control circuit of dc/dc operation

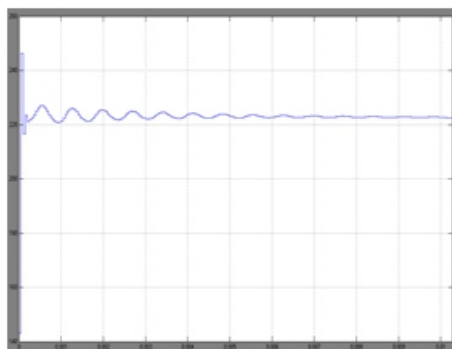

Fig 13: DC voltage

Mode 3:

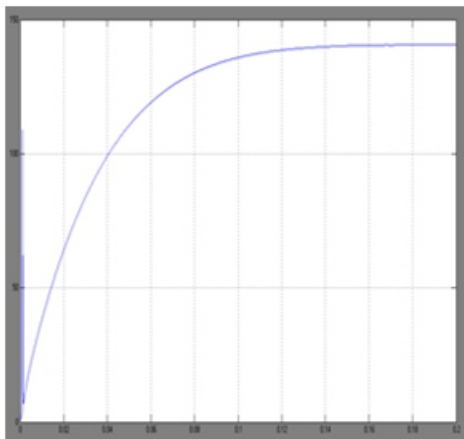

Fig 14: PV voltage

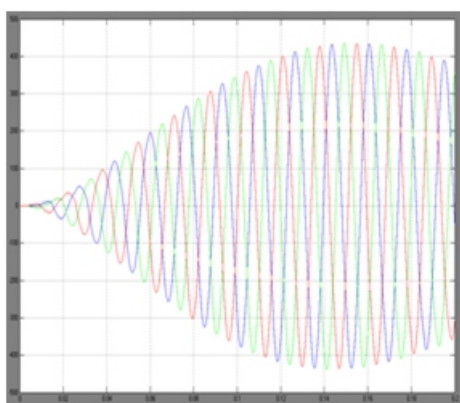

Fig 15: grid voltage

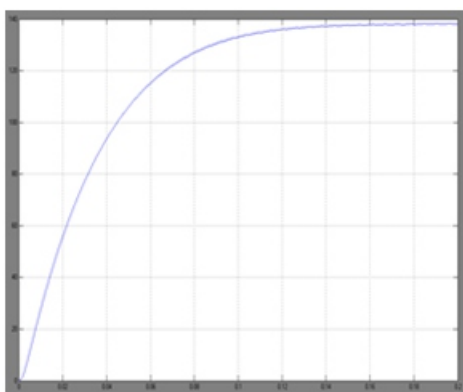

Fig16: dc voltage

Mode 4:



Fig 17: PV voltage

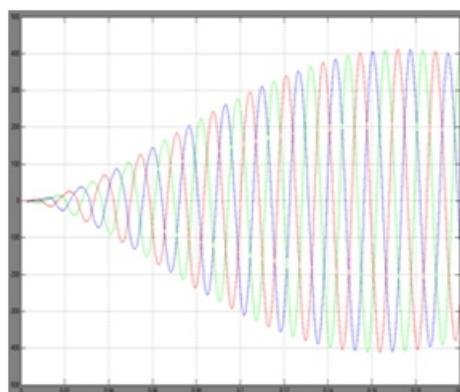

Fig 18: grid voltage

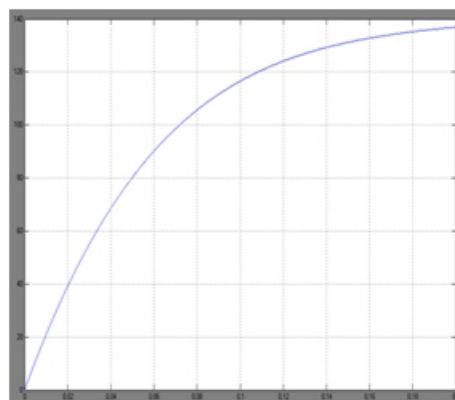

Fig 19: DC voltage

V.CONCLUSION:

This paper introduced a new converter called RSC for PV-battery application, particularly utility-scale PV-battery application. The basic concept of the RSC is to use a single power conversion system to perform different operation modes such as PV to grid (dc to ac), PV to battery (dc to dc), battery to grid (dc to ac), and battery/PV to grid (dc to ac) for solar PV systems with energy storage. The proposed solution requires minimal complexity and modifications to the conventional three-phase solar PV converters for PV-battery systems. Therefore, the solution is very attractive for PV-battery application, because it minimizes the number of conversion stages, thereby improving efficiency and reducing cost, weight, and volume.

REFERENCES:

- [1] U.S. Department of Energy, "Solar energy grid integration systems-energy storage (SEGIS-ES)," May 2008.
- [2] D. Bundestag, "Gesetz zur Neuregelung des Rechts der erneuerbaren Energien im Strombereich und zur Änderung damit zusammenhängender Vorschriften," Bundesgesetzblatt, 2008.
- [3] H. Konishi, T. Iwato, and M. Kudou, "Development of large-scale power conditioning system in Hokuto mega-solar project," in Proc. Int. Power Electron. Conf., 2010, pp. 1975–1979.
- [4] J. H. Enslin and D. B. Snyman, "Combined low-cost, high efficient inverter, peak power tracker and regulator for PV applications," IEEE Trans. Power Electron., vol. 6, no. 1, pp. 73–82, Jan. 1991.
- [5] H. Ertl, J. W. Kolar, and F. Zach, "A novel multi-cell dc-ac converter for applications in renewable energy systems," IEEE Trans. Ind. Electron., vol. 49, no. 5, pp. 1048–1057, Oct. 2002.
- [6] C. Zhao, S. D. Round, and J. W. Kolar, "An isolated three-port bidirectional dc/dc converter with decoupled power flow management," IEEE Trans. Power Electron., vol. 23, no. 5, pp. 2443–2453, Sep. 2008.

[7] M. Bragard, N. Soltan, R. W. De Doncker, and A. Schiemgel, "Design and implementation of a 5 kW photovoltaic system with Li-ion battery and additional dc/dc converter," in Proc. IEEE Energy Convers. Congr. Expo., 2010, pp. 2944–2949.

[8] W. Li, J. Xiao, Y. Zhao, and X. He, "PWM plus phase angle shift control scheme for combined multiport dc/dc converters," IEEE Trans. Power Electron., vol. 27, no. 3, pp. 1479–1489, Mar. 2012.

[9] N. Benavides and P. Chapman, "Power budgeting of a multiple-input buckboost converter," IEEE Trans. Power Electron., vol. 20, no. 6, pp. 1303–1309, Nov. 2005.

Author's Details:

T.Sripal Reddy, M.Tech, Ph.D

Associate professor & HOD,
Department of EEE,
Sarada Institute of Technology &
Sciences, Ragunadhpallem, Khammam.

G.Ravi, M.Tech

Associate professor,
Department of EEE,
Sarada Institute of Technology &
Sciences, Ragunadhpallem, Khammam.



Nimmala Soumya Sri

Power Electronics,
Sarada Institute of Technology &
Sciences, Ragunadhpallem,
Khammam.