

A Wireless Sensor Network for Greenhouse Climate Control



Sd. Arifa

**M.Tech Student,
Department of ECE,
KITS for Women's, kodad, T.S, India.**



Ms. D. Jyothi

**Associate Professor,
Department of ECE,
KITS for Women's, kodad, T.S, India.**

ABSTRACT:

In modern greenhouses, several measurement points are required to trace down the local climate parameters in different parts of the big greenhouse to make the greenhouse automation system work properly. Cabling would make the measurement system expensive and vulnerable. Moreover, the cabled measurement points are difficult to relocate once they are installed.

Thus, a Wireless Sensor Network (WSN) consisting of small-size wireless sensor nodes equipped with radio and one or several sensors, is an attractive and cost-efficient option to build the required measurement system. In this work, we developed a wireless sensor node for greenhouse monitoring by integrating a sensor platform provided by Sensinode Ltd. [1] with three commercial sensors capable to measure four climate variables.

The feasibility of the developed node was tested by deploying a simple sensor network into Martens Greenhouse Research Foundation's greenhouse in Närpiö town in Western Finland. During a one day experiment, we collected data to evaluate the network reliability and its ability to detect the microclimate layers, which typically exist in the greenhouse between lower and upper flora. We were also able to show that the network can detect the local differences in the greenhouse climate caused by various disturbances, such as direct sunshine near the greenhouse walls.

This article is our first step in the area of greenhouse monitoring and control, and it is all about the developed sensor network feasibility and reliability. Data analysis, control solutions and more complex network setups will be left to be the main directions of our future work.

I. INTRODUCTION:

The most important factors for the quality and productivity of plant growth are temperature, humidity, light and the level of the carbon dioxide. Continuous monitoring of these environmental variables gives information to the grower to better understand, how each factor affects growth and how to manage maximal crop productivity [2]. The optimal greenhouse climate adjustment can enable us to improve productivity and to achieve remarkable energy savings - especially during the winter in northern countries [3]. In the past generation greenhouses it was enough to have one cabled measurement point in the middle to provide the information to the greenhouse automation system. The system itself was usually simple without opportunities to control locally heating, lights, ventilation or some other activity, which was affecting the greenhouse interior climate. This all has changed in the modern greenhouses. The typical size of the greenhouse itself is much bigger what it was before, and the greenhouse facilities provide several options to make local adjustments to the lights, ventilation, heating and other greenhouse support systems.

However, more measurement data is also needed to make this kind of automation system work properly. Increased number of measurement points should not dramatically increase the automation system cost. It should also be possible to easily change the location of the measurement points according to the particular needs, which depend on the specific plant, on the possible changes in the external weather or greenhouse structure and on the plant placement in the greenhouse. Wireless sensor network (WSN) can form a useful part of the automation system architecture in modern greenhouses. Wireless communication can be used to collect

the measurements and to communicate between the centralized control and the actuators located to the different parts of the greenhouse. In advanced WSN solutions, some parts of the control system itself can also be implemented in a distributed manner to the network such that local control loops can be formed. Compared to the cabled systems, the installation of WSN is fast, cheap and easy. Moreover, it is easy to relocate the measurement points when needed by just moving sensor nodes from one location to another within a communication range of the coordinator device. If the greenhouse flora is high and dense, the small and light weight nodes can even be hanged up to the plants' branches. WSN maintenance is also relatively cheap and easy.

The only additional costs occur when the sensor nodes run out of batteries and the batteries need to be charged or replaced, but the lifespan of the battery can be several years if an efficient power saving algorithm is applied. In this work we took the very first steps towards the wireless greenhouse automation system by building a wireless measuring system for that purpose and by testing its feasibility and reliability with a simple experimental setup. We integrated three commercial sensors to Sensinode's sensor platform [1]. By using these sensors, we are able to measure four parameters, which are crucial in greenhouse climate adjustment: temperature, relative humidity, light irradiance and air carbon dioxide content. The platform uses 6LoWPAN protocol, which allows us to send compressed IPv6 packets over IEEE 802.15.4 networks.

2. METHODOLOGY:

In the Precision Agriculture (PA) various techniques are available to monitor and control the required environmental parameters for the particular crop. It is particularly crucial to analyse the methods which can effectively manage the proper environment. The use of wireless sensor network for the large area is now becoming popular in greenhouse technology of precision agriculture. The parameters of greenhouse to be controlled are increasing day by day so that it may cause the data traffic and congestion in the future. So that, the wireless sensors derived from PSoC technology with high-bandwidth spectrum or cognitive radio technology may be the proper solution for smooth data traffic and remote control of greenhouse from long distance. With the use of greenhouse concept, the farmer can produce different crops in different climates and various seasons.

In proposed design of the greenhouse, the farmer can easily keep the desired crop's environment conditions. To fulfil this requirement we need the environmental parameter sensors, such as Temperature sensor, humidity sensor, CO2 sensor etc. All these sensors can be connected to server or sink International Journal of Wireless & Mobile Networks (IJWMN) Vol. 3, No. 1, February 2011 141 node without wire. Such a network is called Wireless Sensor Network.

This network can help to monitor and control all the environmental parameters of Precision Agriculture [1]. In a prototype greenhouse (70m x 150m) design for a typical crop capsicum, will approximately require 40 to 50 wireless nodes (sensor and actuators). If we consider more preciseness in monitoring & control, the number of wireless nodes may be more than fifty.

At a particular event, all the sensors may send information to the central node. The management server may face the problem of data congestion and intercommunication between nodes. Such challenges can be overcome by the application based WSN with a specific protocol and system on chip based hardware with programmable radio, which we would like to nominate for design of control for greenhouse. A typical block diagram of wireless sensor node is as shown in figure 1.

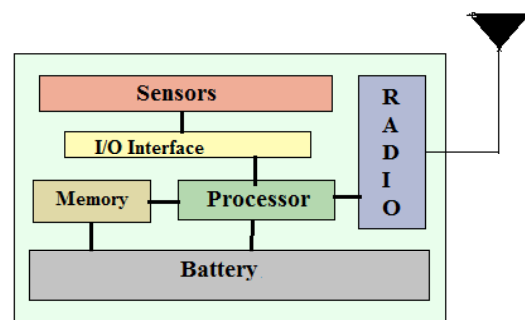

Figure 1, Typical Sensor node Wireless sensor nodes are very small devices that with limited battery source.

Its processing power and memory both are also limited. In automation and control applications, WSN are popular because they are scalable and easy to handle. Now-a-days there are a number of economical sensor nodes available with a high-level technology. They are capable to collect the environmental data with precise sensors and are able to transmit it to control station with high efficiency.

RELATED WORK :

The Rinnovando group [4] is doing research work in a tomato greenhouse in the South of Italy. They are using Sensicast devices for the air temperature, relative humidity and soil temperature measurements with wireless sensor network. They have also developed a Web-based plant monitoring application. Greenhouse grower can read the measurements over the Internet, and an alarm will be sent to his mobile phone by SMS or GPRS if some measurement variable changes rapidly. The Rinnovando group has a test bed in 20 x 50 meters tomato greenhouse. In their test bed, six nodes are deployed into two rows 12.5 m apart from each other. One mesh node works as a repeater and improves the throughput of the communication. Bridge node gathers data from other sensor nodes, which transmit the measurements of temperature and relative humidity in one minute intervals [4]. Liu et al. [5] have developed and tested a WSN prototype for environmental monitoring inside the greenhouse. They are using a star topology network of Crossbow MICAz motes.

The motes measure temperature, humidity and soil moisture, and send their measurements to the sink node in five minutes intervals. Sink node is a combination of MICAz mote and MIB510 board with data terminal. The terminal with ARM processor module shows the latest measurements in LCD-screen inside the greenhouse and delivers the data to the main PC by using GSM module. The central PC located further apart from the network takes care of data logging and processing. Mote programming and data receiving is possible through the RS-232 serial interface provided by MIB510 board. The Received Signal Strength Indicator (RSSI) values over the distance between nodes with different antenna heights and polarization angles were compared to each other. Based on the results it was possible to conclude that the longest communication range was achieved when nodes had same orientation and maximal antenna height. The temperature difference in experimental measurement between two nodes, where one node was placed in the center of the greenhouse and another near the greenhouse wall, indicates the existence of the microclimate layers [5].

PRECISION AGRICULTURE:

The productivity of the greenhouse depends on many different factors. Many research projects are focusing to these factors and their interdependencies. Grower can set

the reference values to certain environmental variables, and then the greenhouse automation system targets to keep the variables in these values. The optimal levels of water and fertilizer can also be defined [5]. Carbon dioxide (CO₂) is a natural gas, which is dangerous for humans in high concentrations, but a lifeline for trees and plants. The air consists of nitrogen, oxygen and carbon dioxide. In the photosynthesis process, the plants convert CO₂, water and light into glucose and oxygen according to $2 \text{ C}_6\text{H}_{12}\text{O}_6 + 6 \text{ H}_2\text{O} + 6 \text{ CO}_2 \xrightarrow{\text{light}} 6 \text{ C}_6\text{H}_{10}\text{O}_5 + 6 \text{ O}_2$. Thus, CO₂ is an important greenhouse climate variable, which enhances the growth of the plants. Sunshine and lights increase the amount of carbon dioxide. During the summer, the greenhouse gets the CO₂ it needs from the natural air, when ventilation and roof windows are open [3]. In northern countries this opportunity does not exist during the winter. Grower can use pure extra CO₂, or he can produce more carbon dioxide by CO₂ burner.

Some greenhouse heating systems re-circulate their CO₂ emissions into the greenhouse making double advantages for the producer [2]. The use of external CO₂ offers also a way to tie the carbon dioxide collected from some industrial process to the biomass grown in the greenhouse instead of emitting it to the atmosphere. The optimal greenhouse air temperature depends on the intended level of the photosynthetic activity. Each plant species has its own optimal values of air temperature and active radiation of light, which enable the maximum photosynthetic activity (see Figure 1). Soil temperature plays also an important role. Conduction heat transfers directly to the soil structure and through convection between the plant roots and water flow around them.

A main concern in humidity and temperature control is to provide the best conductivity to active movement of water and nutrients through the plant. Humidity control is also an important tool to prevent the spread of plant diseases in greenhouses. Normally, the range of healthy relative humidity for the plants is from 50% to 70%. High air moisture reduces the required plant watering frequency. The greenhouse automation uses the watering and misting system, if the air moisture decreases under the targeted level [6]. Temperature and humidity are closely linked together in a greenhouse. Cold air has a lower moisture-holding capacity than warmer air, and therefore the decrease of the relative humidity is a sign of increased air temperature [3]. Transpiration rate tells how many grams plant's leaf surface called stomata releases water vapour per minute.

The greenhouse protects the plants from the extreme weather conditions. However, if the period of daylight prevents the photosynthetic activity, the plants do not grow. Horticultural lighting allows the grower to extend the growing season. It enables a year-round producing of plants or makes it possible for the grower to start sowing in early spring and continue season till the first frost. Plants need about 10-12 hours light to improve growth. When the plants are producing flowers or fruits the supplemental need of light per day increases up to 16 hours. Figure 1 shows the photosynthetic activity in different wavelengths of light radiation [2].

EXPERIMENTAL SETUP IN A GREENHOUSE :

The Greenhouse Environment We made our experiments in Martens Greenhouse Research Center's greenhouse in the Närpiö town in Western Finland [7]. The size of the greenhouse was 18 x 80 meters and in its traditional control system it has only one cabled measurement unit in the middle. Greenhouse's moist climate and dense flora are similar to the surroundings of a jungle. This kind of environment is challenging both for the sensor node electronics and for the short-range IEEE 802.15.4 wireless network, which communication range is much longer in open areas. Therefore, we limited the distances between communicating nodes to 15 meters in our deployment.

B. Sensor Nodes The wireless sensor node we used was Sensinode's Micro.2420 U100 (see Figure 3).

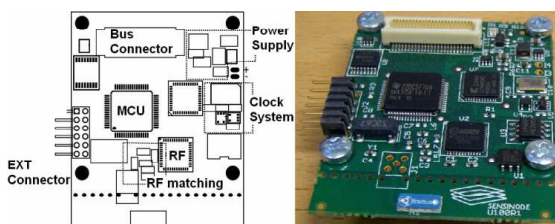

[6]. It operated as a basic measuring node with a CC2420 802.15.4 RF-transceiver and a MSP430 Microcontroller. The gateway node was a combination of U100 node and USB serial adapter board (Micro.USB U600) [1]. Sensors were soldered to a board equipped with the needed components (resistors, capacitors and operation amplifier). Then the sensor board (see Figure 4 on the left) was plugged in to the U100 node through its I/O pins. The node and two 1,5V AA-batteries acting as a power source were sheltered by a plastic box (80*55*33mm) to prevent them from the humidity.

Sensor board was placed on the top of the box and sensitive electrical components were protected from the moisture by a plastic coating spray. Finally, the whole board was enveloped by ESD plastic sachet leaving only the heads of the sensors outside. Fig. 3. Sensinode's Micro.2420 U100. The node is equipped with ZigBee radio, but it operates under 6LoWPAN protocol. Sensinode's devices are based on 6LoWPAN protocol, which enables transmission of compressed Internet Protocol version 6 (IPv6) packets over IEEE 802.15.4 networks [8]. Sensinode's Nanostack protocol provides the use of 6LoWPAN and a standard Socket API for accessing the network. It works in 2,4GHz ISM band and offers 250 kbps data rate [9]. C. Sensors Fast response time, low power consumption and tolerance against moisture climate made SHT75 relative humidity and temperature sensor [10] a perfect solution for the greenhouse environment.

Temperature accuracy of the sensor is ± 0.3 °C and the accuracy of the relative humidity under ± 2 %. Communication between SHT75 sensor and node is similar to IIC interface developed by Philips. Data and clock line are the same in both cases, but SHT75 has only one pull-up resistor between data and power supply line. Luminosity was measured by TAOS TSL262R [11], which converts light intensity to voltage. Unstable output signal is handled by low-pass filter to get correct luminosity values. We mounted irradiance, temperature and humidity sensors into four nodes, but Carbon dioxide sensor was tricky because it sets special requirements for the input voltage and the response time. Figaro's TGS4161 [12] carbon dioxide sensor (see Figure 4 on the right) was the alternative, which was the most compatible with low voltage sensor node. CO₂ measuring takes longer time than other measurements and CO₂ sensor voltage supply must be within ± 0.1 V from the 5 Volts.

The carbon dioxide value can be read from the output voltage. Operation amplifier raises the voltage level of otherwise weak signal from the sensor. We end up to left the TGS4161 to be implemented in its own node which can also act as a router node in a multi hop network, which will be part of the future work. D. Node Deployment and Network Architecture We applied a simple star topology, where four nodes with temperature, luminosity and humidity sensors measured climate variables and communicated directly with the gateway node. The gateway node acted as a coordinator and received the measured data from the sensor nodes.

It was located in the greenhouse entrance hall because the humidity there was 20-30% lower than inside the greenhouse. A laptop computer was connected to the gateway node by USB-cable. Martens greenhouse was divided into vertical blocks and the nodes monitored one block at a time. Figure 5 illustrates how the sensor nodes were deployed to the greenhouse block. The idea of the vertical deployment was to get a better understanding of the microclimate layers which typically exist in the greenhouse, and to figure out what kind of differences occur in the climate between lower and upper flora.

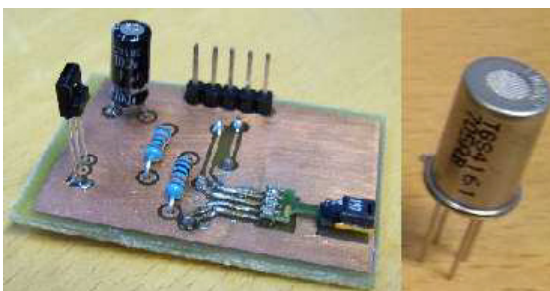

Fig. 4. Sensor board (equipped with luminosity and temperature/humidity sensors) and carbon dioxide sensor.

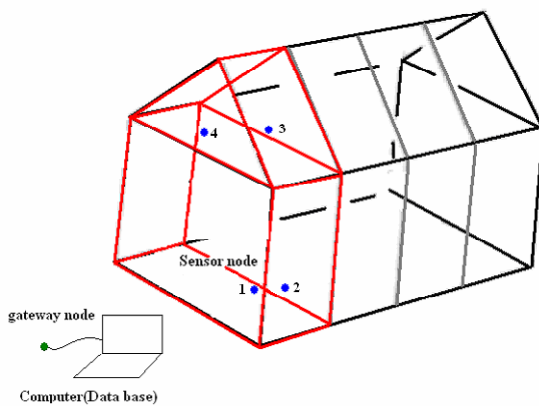

Fig. 5. Experimental setup in Martens greenhouse.

Node 1 (see Figure 5) was placed 490 cm away from the glazed side wall of the greenhouse. It was hanged in 120 cm height and the distance to the edge of dense tomato foliage was 410 cm. Node 2 had 180 cm distance to the side wall and it was placed at the height of 176 cm. That location was a shadowy spot where the nearest lamp was broken. The length between the first plants and the device was 174 cm. Node 3 measured the crown layer in 310 cm height just above the Node 1. Node 4 was in the middle of the greenhouse block 930 cm away from the side wall and hanged at a height of 295 cm. The distance from the node to the edge of the foliage was 135 cm. Node 2 and Node 3 are shown in Figure 6.



Periodical sleep and wake modes were applied. In its turn, each node woke up and turned on its radio for 15 seconds, and went then back to sleep and turned off its radio for 255 seconds (4 min 15 s). At a time, only one of the four nodes equipped with temperature, luminosity and humidity sensors was reading data from the sensors and waiting data request from the coordinator. The coordinator took care of data requesting, and the other nodes were only able to answer to the request. Thus, the coordinator acted as a master device, which polled data from the sensor nodes in certain time periods. Collisions between other node transmissions were easily avoided in this way.

6. Experimental Results:

In our experimental setup, four nodes were deployed to one greenhouse block to gather information about the differences in climate variables between lower and upper flora. Each node read temperature, humidity and irradiance values once in four minute intervals over three hours. During the experiment, the coordinator sent 200 data requests, and each sensor node responded 50 times. Ten packets with readings were either lost or received incorrectly. That indicated 5% data loss rate in terms of packets. The maximal communication range, 15 meters was figured out in individual test where the distance between the coordinator and the sensor node inside the greenhouse dense flora was increased until the connection was lost. We also observed that the reliable range in terms of tolerable packet loss was approximately 10 meters.

Compared to our previous experiment in an open parking lot, the reliable communication range fell to one third in the greenhouse's dense flora. A fickle weather on the measurement day affected the results. The sun was shining for a half an hour in the beginning of the test and later on during shorter periods of the day. The greenhouse environmental control system, Priva[13], adjusted the ventilation, heating and misting according to new samples once in 15 minutes. Priva's measurement box located in the middle of the greenhouse, and the block where our sensor nodes were deployed, was in the greenhouse's south end.

The temperature values measured by four wireless sensor nodes are shown in Figure 7. Local temperature values were strongly influenced by the sunshine at the beginning of the experiment period. Node 1 was far away from the greenhouse ceiling and from both greenhouse walls. Thus, the temperature stayed stable in its area for most of the time. The 15 minutes sampling period in the greenhouse control system explains, why temperature raised over 30 Celsius in some spots before the control system opened the roof windows. Later on, a partly cloudy weather balanced the results between the nodes for the rest of the experiment. Fig. 7. Temperature measurement results. Fig. 8. Relative humidity measurement results. Node 3 and Node 4 were both placed on the crown layer of the tomato growth. A slant ceiling of the greenhouse made the distance between Node 4 and the ceiling three meters longer than distance between Node 3 and the ceiling. Therefore, the measurements provided by node 4, indicated one degree lower temperature.

Node 2 was located near the side wall of which the sun was heating raising the temperature measured by the node. The relation between the humidity and temperature was explained in Chapter III. The measurements collected by the nodes verified the fact that the lowering of the relative humidity increases the air temperature and vice versa. Figure 8 shows the changes in relative humidity between four nodes. Comparison between temperature and humidity values (Figures 7 and 8) shows how variables are linked together. For example, two distinct drops in humidity are clearly to be seen in the Figure 8. Temperature values increased at the same time when moisture dropped, as shown in Figure 7. Relative humidity did not differ much between the nodes. Node 1 and Node 2 were placed on a shadowy spot, and they measured a little bit higher moisture than nodes on the upper layer.

CONCLUSIONS:

In green house technology, more number of the parameters is to be control because, the varieties of the crop are large. They are increasing day by day because of the development in agriculture technology. In this situation, the wireless sensor network with additional hardware and software is an efficient solution for green house control. Experimentally it is proved that the hardware developed by Cypress Inc. is the best solution which works on low power with less complexity and high reliability for greenhouse control.

In the future, if parameter still increase, then for WSN technology with currently available bandwidth, may not be sufficient. Then WSN with cognitive radio technology may be the solution. This advancement in precision agriculture through Wireless Sensor Network in green house control is extremely useful. This has scope in developing countries in globe, where agriculture is the main business.

ACKNOWLEDGMENTS:

I am Sd.Arifa and would like to thank the publishers, researchers for making their resources material available. I am greatly thankful to Assistant Prof: Miss.B.Jyothirmayee for their guidance. We also thank the college authorities, PG coordinator and Principal for providing the required infrastructure and support. Finally, we would like to extend a heartfelt gratitude to friends and family members .

REFERENCES:

- [1] J. Burrell et al. Vineyard computing: sensor networks in agricultural production. *IEEE Pervasive Computing*, 3(1):38–45, Jan-Mar 2004.
- [2] Blackmore, S. (1994). —Precision Farming: An Introduction. *Outlook on Agriculture* 23(4) 4, 275-280.
- [3] Ning Wang, Naiqian Zhang, Maohua Wang, —Wireless sensors in agriculture and food Industry —Recent development and future perspective, published in *Computers and Electronics in Agriculture* 50 (2006) 1–14.
- [4] R. Beckwith, D. Teibel, and P. Bowen, “Unwired wine: sensor networks in vineyards,” 2004, pp. 561- 564.
- [5] A. Baggio, “Wireless Sensor Networks in Precision Agriculture,” 2005
- [6] I. F., Su, W., Sankarasubramaniam, Y., & Cayirci, E. (2002). —Wireless sensor networks: a survey on Computer Networks, 38, 393-422.
- [7] H. Liu, Z. Meng and S. Cui, “ A Wireless Sensor Network Prototype for Environmental Monitoring in Greenhouses,” presented at *Wireless Communications, Networking and Mobile Computing 2007 (WiCom 2007)*, International Conference on 21-25 Sept. 2007 Page(s): 2344 – 2347.

[8] M. Åberg Secher, "Kasvihuone," Otava, Helsinki, Finland, Page(s): 25– 80, 1998.

[9] Martens Greenhouse Research Center Web-page, <http://www.martens.fi> (referred 17.5.2008).

[10] G. Montenegro and N. Kushalnagar, "Transmission of IPv6 Packets over IEEE 802.15.4 Networks," Internet-Draft, IETF, September 2007.[Online]. Available: <http://www.ietf.org>.

[11] Sensinode (2007). NanoStack manual v1.0.1. [Online]. Available: www.sensinode.com.

[12] Sensirion (2007). SHT1x / SHT7x Humidity & Temperature Sensor v.3.0.1.[Online]. Available:http://www.sensirion.com/en/pdf/product_information/Data_Sheet_humidity_sensor_SHT1x_SHT7x_E.pdf.

[13] Texas Advanced Optoelectronic Solutions Inc. (2003). TSL260R, TSL261R, TSL262R Light to voltage optical sensors. [Online]. Available:<http://www.roborugby.org/docs/Taos-TSL260R.pdf>.

[14] Figaro engineering inc. (2003). TGS 4161 - for the detection of Carbon Dioxide.[Online]. Available:<http://www.figarosensor.com/products/4161pdf>.

[15] PRIVA - Greenhouse Environmental Control Systems. [Online]. Available: <http://www.priva.ca>

Author's Details:

Ms.Sd.Arifa, MTech student, in M.Tech Student, Dept of ECE in KITS for women's, kodad, T.S, India.

Ms.D.Jyothi, working as a Assistant at ECE in KITS for women's,kodad, T.S, IndiaJNTUH Hyderabad. she has 5 years of UG/PG Teaching Experience