

Simulation of Grid Connected PV System with Power Quality Improvement Using Fuzzy Logic Controller

T.Sripal Reddy

Associate professor & HoD
Department of Electrical &
Electronics Engineering,
Sarada Institute of Technology &
science,
Khammam, Telangana, India.

G.Ravi

Associate Professor
Department of Electrical &
Electronics Engineering,
Sarada Institute of Technology &
science,
Khammam, Telangana, India.

Kosuri Jayakar

M.Tech Student
Department of Electrical &
Electronics Engineering,
Sarada Institute of Technology &
science,
Khammam, Telangana, India.

ABSTRACT

The increased power demand, the depletion of the fossil fuel resources and the growth of the environmental pollution has led the world to think seriously of other alternative sources of energy. So renewable energy resources (RES) are being connected to the distribution systems, mostly done by using power electronic converters. A new control strategy for achieving maximum advantage from these grid-interfacing inverters which are when installed in 3-phase 4-wire distribution systems is given in this paper. With the inverter control, the inverter can be used as a multi-function device, which includes the function of: 1) power converter to inject power generated from RES to the grid, and 2) shunt APF to compensate current unbalance, load current harmonics, load reactive power demand and load neutral current. These functions of the inverter can be done either individually or simultaneously. The proposed inverter with the control when connected, helps the 3-phase 4-wire linear/non-linear unbalanced load at point of common coupling appear as balanced linear load to the grid. In this control strategy fuzzy based system is used for performance improvement with MATLAB/Simulink simulation studies, the proposed control technique is demonstrated and evaluated here.

Key Words - distributed generation (DG), distribution system, grid interconnection, power quality (PQ), renewable energy, Point of common coupling (PCC).

I.INTRODUCTION

Electrical power is the most widely used source of energy for our household's equipments, industries and work places. Population and industrial growth has led to significant increases in power consumption over the past decades. Natural resources like petroleum, coal and gas that have driven our industries, power plants and vehicles for many decades are becoming depleted at Avery fast rate. This is an important issue, which has motivated nations across the world to think about alternative forms of energy which utilize inexhaustible natural resources. The combustion of conventional fossil fuel across the globe has caused increased level of environmental pollution .Several international conventions and forums have been set up to address and resolve the issue of climate change. These forums have motivated countries to form national energy policies dedicated to pollution control, energy conservation, energy efficiency, development of alternative and clean sources of energy. Renewable energy like solar, wind, and tidal currents of oceans is sustainable, inexhaustible and environmentally friendly clean energy. Due to all these factors, wind power generation has attracted great interest in recent years. Undoubtedly, wind power is today's most rapidly growing renewable energy source.

Distributed generation (DG) is termed as the integration of Renewable energy source (RES) at the distribution level. The number of distributed generation (DG) units, including both renewable and non renewable sources, for small rural communities not connected to the grid and for small power

resources connected to the utility network has grown in the last years. The integration of renewable energy systems (RESs) in smart grids (SGs) is a challenging task, mainly due to the intermittent and unpredictable nature of the sources, typically wind or sun. So for the reliable operation of the system, continuous control is needed. This can be obtained by the help of digital control and power electronic devices which may improve the power quality of the system at the PCC. The quality of power in the system is mainly affected by the harmonic current produced by the non-linear loads and power electronic based instruments [1],[2].

In the distributed system, the intermittent RES is connected using current controlled voltage source inverters. New control strategies for grid connected inverters with PQ solution have been proposed. In [3] an inverter operates as active inductor at a certain frequency to absorb the harmonic current. The control performance may be decreased because of the complexity in exact calculation of network impedance in real time. In [4] a cooperative control of multiple active filters based on voltage detection for harmonic damping throughout a power distribution system is proposed.

In [5], a control strategy for renewable interfacing inverter based on p-q theory is proposed. This strategy includes both load and inverter current sensing which is required to compensate the load current harmonics. Voltage harmonics which is caused by non-linear load current harmonics can create serious PQ problem in the power system network. To compensate this, Active power filters (APF) are extensively which may result in additional hardware cost. This paper suggests how to include the APF in the conventional inverter interfacing renewable with the grid, without any additional hardware cost.

In this paper that the grid-interfacing inverter can effectively be utilized to perform the following four important functions: 1) transfer of active power harvested from the renewable resource (wind); 2) load reactive power demand support; 3) current harmonics compensation at PCC; and 4) current unbalance and neutral current compensation in case of 3-phase 4-wire

system. All the four objectives can be accomplished either individually or simultaneously with adequate control of grid-interfacing inverter. So without additional hardware cost the PQ constraints at the PCC can therefore be strictly maintained within the utility standards.

II. SYSTEM DESCRIPTION

The proposed system consists of RES connected to the dc link of a grid-interfacing inverter as shown in Fig. 1. It is shows that both load are connected that is non-linear load as well as unbalance load at distribution. Grid is connected to step down transformer with reduce voltage level for distribution side as shown in fig. 1. For injecting Renewable energy to grid inverter that is power electronic devices is used. Power electronic devices produces the unwanted harmonics to reduce this shunt active power filter is used. Shunt active power filter is used to compensate load current harmonics by injecting equal but opposite compensating current.

In this paper three phase four wire voltage source current controlled inverter is used. Generally three wire inverter is used but in this fourth terminal is used to compensate the neutral current. A voltage source inverter is convert renewable DC energy into Ac with required magnitude, phase angle and frequency. It also converts the DC voltage across storage devices into a set of three phase AC output voltages. It is also capable to generate or absorbs reactive power. If the output voltage of the VSC is greater than AC bus term in a voltages, is said to be in capacitive mode. So, it will compensate the reactive power through AC system. The type of power switch used is an IGBT in anti-parallel with a diode. The three phase four leg VSI is modeled in Simulink by using IGBT. The driving voltage across the inductance determines the maximum di/dt that can be achieved by the filter. A large value of inductance is better for isolation from the power system and protection from transient distribution it also limit the ability of the active filter to cancel higher order harmonics.

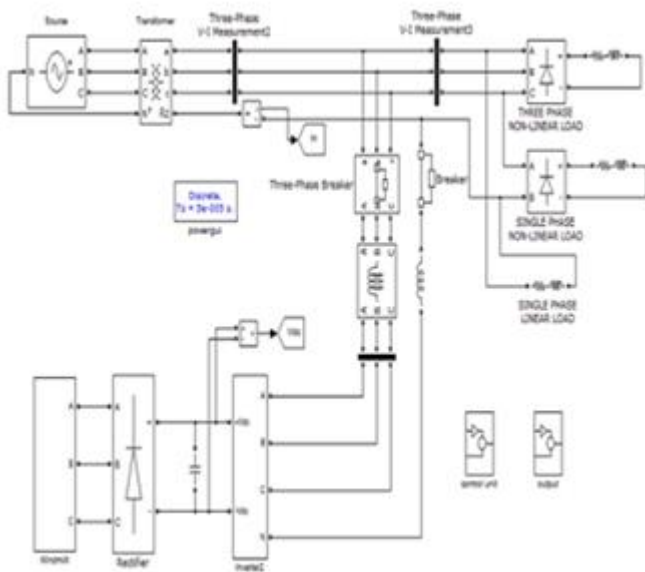

Fig. 1. Schematic of proposed renewable based distributed generation system.

III. CONTROL STRATEGY

A. DC-Link Voltage and Power Control Operation

Due to the intermittent nature of RES, the generated power is of variable nature. The dc-link plays an important role in transferring this variable power from renewable energy source to the grid. RES are represented as current sources connected to the dc-link of a grid-interfacing inverter. Fig. 1 shows the systematic representation of power transfer from the renewable energy resources to the grid via the dc link. The dc-capacitor decoupled the RES from grid and allows the independent control of inverter on either side of dc link. P1 to P8 switching signal of inverter where P 7 and P8 are multiplied with constant zero to compensate the neutral current.

B. Control of Grid Interfacing Inverter

The control diagram of grid- interfacing inverter for a 3-phase 4-wire system is shown in Fig. 2. To compensate the neutral current of load, a fourth leg is provided to the inverter. The proposed approach is mainly concerned about the regulation of power at PCC during three conditions like, when 1) PRES = 0; 2) PRES < total power (PL); and 3) PRES > PL. During the power management operation, the inverter is controlled in such a way that it always draws/

supplies fundamental active power from/ to the grid. If the load connected to the PCC is non-linear or unbalanced or the combination of both, the given control approach also compensates the harmonics, unbalance, and neutral current. By the control, duty ratio of inverter switches are varied in a power cycle in order to get the combination of load and inverter injected power to be appearing as balanced resistive load to the grid

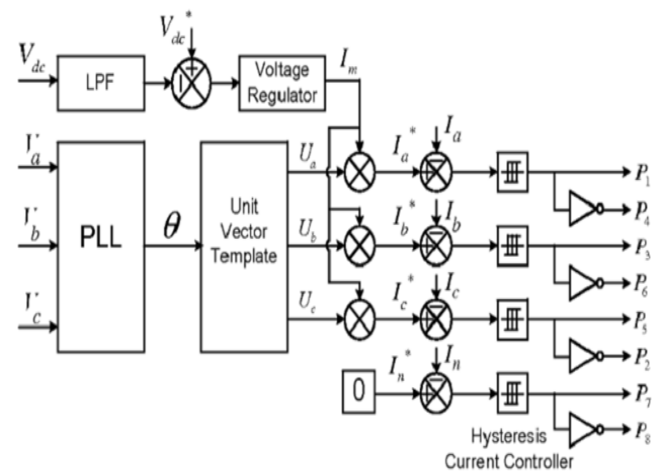

Fig. 2. Block diagram representation of grid-interfacing inverter control.

The exchange of active power in between renewable source and grid can be obtained from the regulation of dc-link voltage. Thus the output of dc-link voltage regulator results in an active current (I_m). The multiplication of this active current component (I_m) with unity grid voltage vector templates (U_a, U_b , and U_c) generates the reference grid currents (I_a^*, I_b^* , and I_c^*) for the control process. The reference grid neutral current (I_n^*) is set to zero, being the instantaneous sum of balanced grid currents. Phase locked loop (PLL) is used to generate unity vector template from which the grid synchronizing angle (θ) is obtained.

$$U_A = \sin \theta \quad (1)$$

$$U_A = \sin\left(\theta - \frac{2\pi}{3}\right) \quad (2)$$

$$U_A = \sin\left(\theta + \frac{2\pi}{3}\right) \quad (3)$$

The actual dc-link voltage (VDC) is sensed and passed through a first-order low pass filter (LPF) to eliminate the presence of switching ripples on the dc-link voltage and in the generated reference current signals. The difference of this filtered dc-link voltage and reference dc-link voltage (VDC*) is given to a discrete-PI regulator to maintain a constant dc-link voltage under varying generation and load conditions.

The dc-link voltage error VDCerr(N) at nth sampling instant is given as:

$$V_{DCerr(N)} = V_{DC(N)}^* - V_{DC(N)} \quad (4)$$

The output of discrete-PI regulator at nth sampling instant is expressed as

$$I_{m(N)} = I_{m(N-1)} + K_{PVdc} (V_{DC(N)} - V_{DC(N-1)}) + K_{IVdc} V_{DCerr(N)} \quad (5)$$

Where K_{PVdc} and K_{IVdc} are proportional and integral gains of dc-voltage regulator. The instantaneous values of reference three phase grid currents are computed as

$$I_A^* = I_m \cdot U_A \quad (6)$$

$$I_B^* = I_m \cdot U_B \quad (7)$$

$$I_C^* = I_m \cdot U_C \quad (8)$$

The neutral current, present if any, due to the loads connected to the neutral conductor should be compensated by fourth leg of grid-interfacing inverter and thus should not be drawn from the grid. In other words, the reference current for the grid neutral current is considered as zero and can be expressed as:

$$I_N^* = 0 \quad (8)$$

The reference grid currents (I_A^* , I_B^* , I_C^* and I_N^*) are compared with actual grid currents (I_A , I_B , I_C and I_N) to compute the current errors as:

$$I_{Aerr} = I_A^* - I_A \quad (9)$$

$$I_{Berr} = I_B^* - I_B \quad (10)$$

$$I_{Cerr} = I_C^* - I_C \quad (11)$$

$$I_{Nerr} = I_N^* - I_N \quad (12)$$

These current errors are given to hysteresis current controller. The hysteresis controller then generates the switching pulses (P1, P2, P3, P4, P5, P6, P7, and P8) for the gate drives of grid-interfacing inverter.

The switching pattern of each IGBT inside inverter can be formulated on the basis of error between actual and reference current of inverter, which can be explained as:

If $I_{InvA} < (I_{InvA}^* - h_b)$, then upper switch will be OFF (P1=0) and lower switch S4 will be ON (P4=1) in the phase "A" leg of inverter.

If $I_{InvA} > (I_{InvA}^* + h_b)$, then upper switch will be ON (P1=1) and lower switch S4 will be OFF (P4=0) in the phase "a" leg of inverter.

Where h_b is the width of hysteresis band. Similarly switching pulses are derived for other three legs.

IV. INTRODUCTION TO FUZZY LOGIC CONTROLLER

A new language was developed to describe the fuzzy properties of reality, which are very difficult and sometime even impossible to be described using conventional methods. Fuzzy set theory has been widely used in the control area with some application to dc-to-dc converter system. A simple fuzzy logic control is built up by a group of rules based on the human knowledge of system behavior. Matlab/Simulink simulation model is built to study the dynamic behavior of dc-to-dc converter and performance of proposed controllers. Furthermore,

design of fuzzy logic controller can provide desirable both small signal and large signal dynamic performance at same time, which is not possible with linear control technique. Thus, fuzzy logic controller has been potential ability to improve the robustness of dc-to-dc converters. The basic scheme of a fuzzy logic controller is shown in Fig 5 and consists of four principal components such as: a fuzzy fication interface, which converts input data into suitable linguistic values; a knowledge base, which consists of a data base with the necessary linguistic definitions and the control rule set; a decision-making logic which, simulating a human decision process, infer the fuzzy control action from the knowledge of the control rules and linguistic variable definitions; a de-fuzzification interface which yields non fuzzy control action from an inferred fuzzy control action [10].

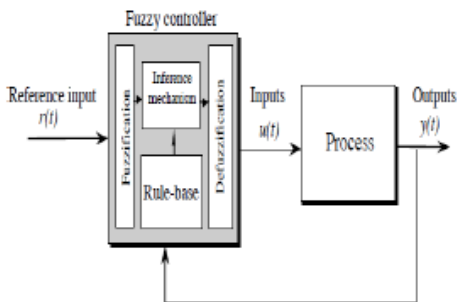

Fig.3. General structure of the fuzzy logic controller on closed-loop system

The fuzzy control systems are based on expert knowledge that converts the human linguistic concepts into an automatic control strategy without any complicated mathematical model [10]. Simulation is performed in buck converter to verify the proposed fuzzy logic controllers.

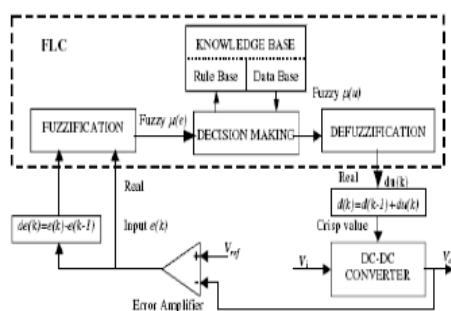

Fig.4. Block diagram of the Fuzzy Logic Controller (FLC) for dc-dc converters

Fuzzy Logic Membership Functions:

The dc-dc converter is a nonlinear function of the duty cycle because of the small signal model and its control method was applied to the control of boost converters. Fuzzy controllers do not require an exact mathematical model. Instead, they are designed based on general knowledge of the plant. Fuzzy controllers are designed to adapt to varying operating points. Fuzzy Logic Controller is designed to control the output of boost dc-dc converter using Mamdani style fuzzy inference system. Two input variables, error (e) and change of error (de) are used in this fuzzy logic system. The single output variable (u) is duty cycle of PWM output.

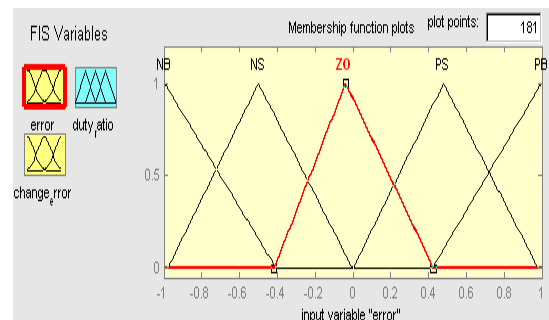

Fig. 5. The Membership Function plots of error

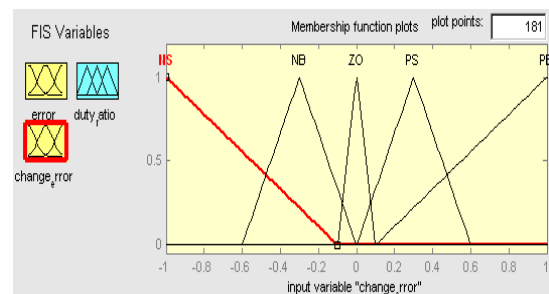

Fig.6. The Membership Function plots of change error

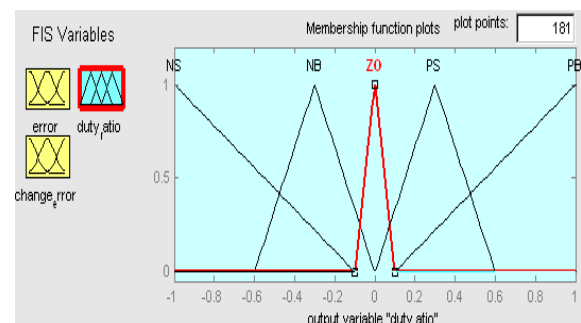

Fig.7. The Membership Function plots

Fuzzy Logic Rules:

The objective of this dissertation is to control the output voltage of the boost converter. The error and change of error of the output voltage will be the inputs of fuzzy logic controller. These 2 inputs are divided into five groups; NB: Negative Big, NS: Negative Small, ZO: Zero Area, PS: Positive small and PB: Positive Big and its parameter [10]. These fuzzy control rules for error and change of error can be referred in the table that is shown in Table II as per below:

Table II

Table rules for error and change of error

(de) \ (e)	NB	NS	ZO	PS	PB
NB	NB	NB	NB	NS	ZO
NS	NB	NB	NS	ZO	PS
ZO	NB	NS	ZO	PS	PB
PS	NS	ZO	PS	PB	PB
PB	ZO	PS	PB	PB	PB

V. SIMULATION RESULTS

For the simulation studies to verify the proposed control approach to achieve multi-objectives for grid interfaced DG systems connected to a 3-phase 4-wire network is carried out using MATLAB/Simulink. To achieve balanced sinusoidal grid currents at unity power factor (UPF) despite of highly unbalanced nonlinear load at PCC under varying renewable generating conditions, a 4- leg current controlled voltage source inverter is actively controlled. A RES with variable output power is connected on the dc-link of grid-interfacing inverter. On the PCC, an unbalanced 3-phase 4-wire nonlinear load, whose unbalance, harmonics, and reactive power need to be compensated, is connected.

Case 1: By using PI controller

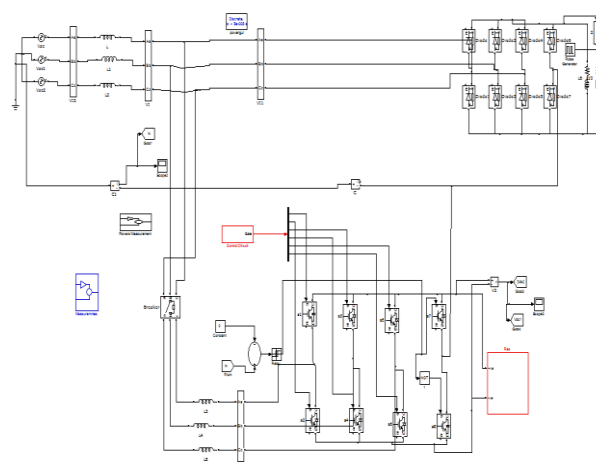

Fig.8.simulink circuit for proposed system

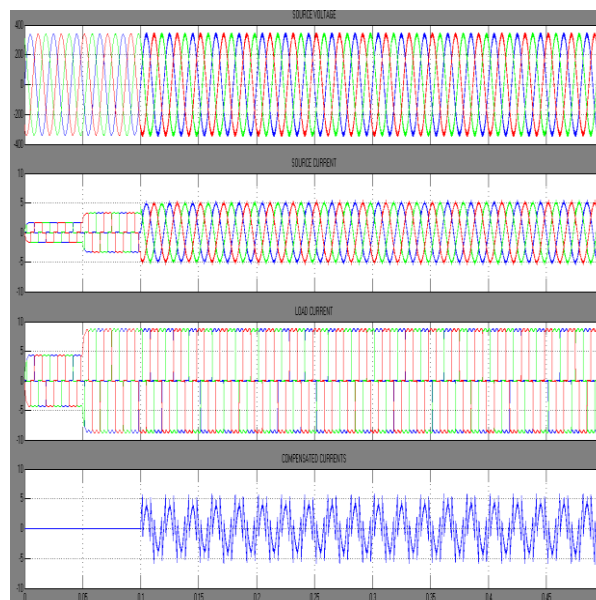

Fig.9. simulation results for (a) source voltage (b) source current (c) load current (d) compensated currents

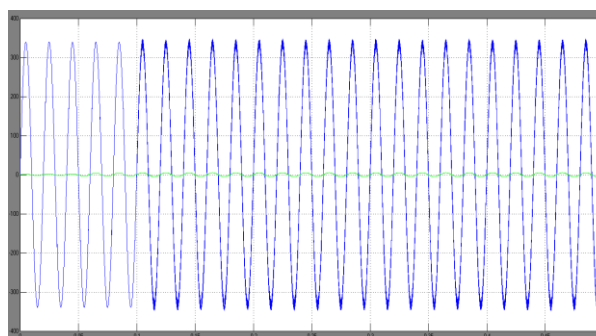

Fig.10. simulation results for source power factor

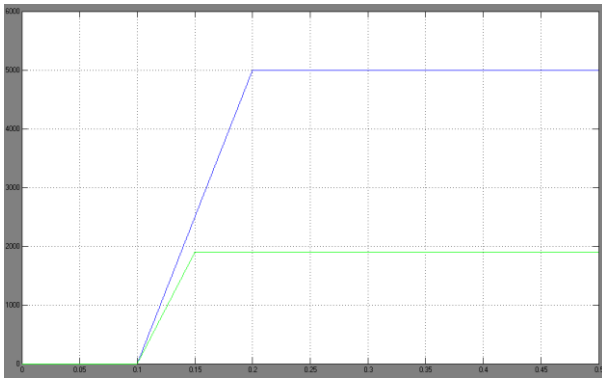

Fig.11. active and reactive power of the source

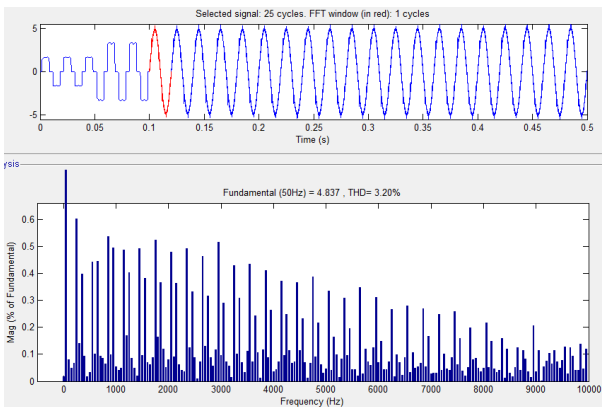

Fig.12. FFT analysis for source current by using PI controller

Case 2: By using fuzzy controller

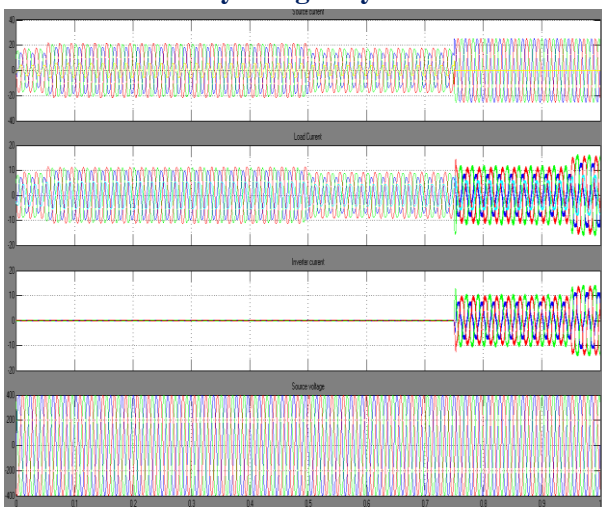

Fig.13. simulation results for (a) source voltage (b) source current (c) load current (d) compensated currents

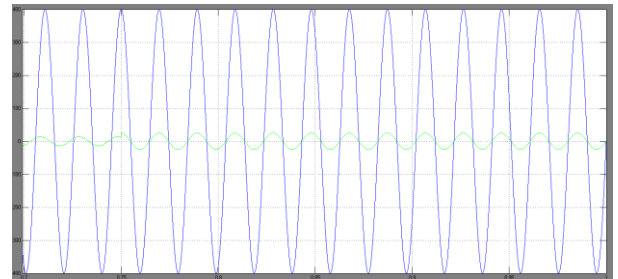

Fig.14. simulation results for source power factor

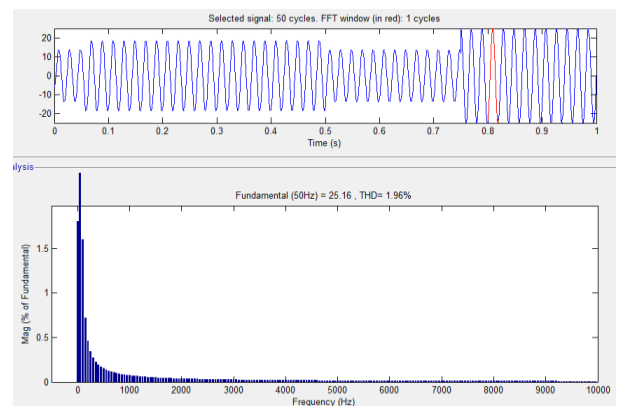

Fig.15. FFT analysis for source current by using fuzzy controller

V.CONCLUSION

This paper has introduced a new control of an existing grid interfacing inverter to improve the power quality at PCC for a 3-phase 4-WireDGsystem. The ability of the grid-interfacing inverter to be effectively used for the power conditioning without affecting its normal operation of real power transfer is also shown. The grid-interfacing inverter with the proposed technique can be utilized to:

- i) inject real power generated from RES to the grid, and/or,
- ii) operate as a shunt Active Power Filter (APF).

This approach helps to improve the quality of power at PCC without the need of additional power conditioning equipment. Extensive MATLAB/Simulink results have validated the proposed approach and have shown that the grid-interfacing inverter can be utilized as a multi-function device. The simulation demonstrates that the PQ enhancement can be achieved under three different

scenarios: 1) $PRES = 0$; 2) $PRES < PLoad$; and 3) $PRES > PLoad$. The current unbalance, current harmonics and load reactive power, due to unbalanced and non-linear load connected to the PCC, are compensated effectively such that the grid side currents are always maintained as balanced and sinusoidal at unity power factor. The fourth leg of inverter prevents the load neutral current from flowing into the grid side by compensating it locally. When the power generated from RES is more than the total load powerdemand, the grid-interfacing inverter with the proposed control approach not only fulfills the total load active and reactive power demand (with harmonic compensation) but also delivers the excess generated sinusoidal active power to the grid at unity power factor.

REFERENCES

- [1] J. M. Guerrero, L. G. de Vicuna, J. Matas, M. Castilla, and J. Miret, "A wireless controller to enhance dynamic performance of parallel inverters in distributed generation systems," *IEEE Trans. Power Electron.*, vol. 19, no. 5, pp. 1205–1213, Sep. 2004.
- [2] J. H. R. Enslin and P. J. M. Heskes, "Harmonic interaction between a large number of distributed power inverters and the distribution network," *IEEE Trans. Power Electron.*, vol. 19, no. 6, pp. 1586–1593, Nov. 2004.
- [3] U. Borup, F. Blaabjerg, and P. N. Enjeti, "Sharing of nonlinear load in parallel-connected three-phase converters," *IEEE Trans. Ind. Appl.*, vol. 37, no. 6, pp. 1817–1823, Nov./Dec. 2001.
- [4] P. Jintakosonwit, H. Fujita, H. Akagi, and S. Ogasawara, "Implementation and performance of cooperative control of shunt active filters for harmonic damping throughout a power distribution system," *IEEE Trans. Ind. Appl.*, vol. 39, no. 2, pp. 556–564, Mar./Apr. 2003.
- [5] J. P. Pinto, R. Pregitzer, L. F. C. Monteiro, and J. L. Afonso, "3-phase 4-wire shunt active power filter with renewable energy interface," presented at the Conf. IEEE Renewable Energy & Power Quality, Seville, Spain, 2007.
- [6] F. Blaabjerg, R. Teodorescu, M. Liserre, and A. V. Timbus, "Overview of control and grid synchronization for distributed power generation systems," *IEEE Trans. Ind. Electron.*, vol. 53, no. 5, pp. 1398–1409, Oct. 2006.
- [7] J. M. Carrasco, L. G. Franquelo, J. T. Bialasiewicz, E. Galván, R. C. P. Guisado, M. Á. M. Prats, J. I. León, and N. M. Alfonso, "Power electronic systems for the grid integration of renewable energy sources: A survey," *IEEE Trans. Ind. Electron.*, vol. 53, no. 4, pp. 1002–1016, Aug. 2006.