

Development of a Laser-Range-Finder Based Human Tracking and Control Algorithm for a Marathoner Service Reboot



Syed Moinuddin Azmeeri Chisty

M.Tech (Embedded System)

Department of E.C.E

Miracle Educational Society Group of Institutions,
 Vizianagaram, AP, India.



Mr. Budireddi Siva Prasad, M.Tech., (Ph.D)

Associate Professor & HoD

Department of E.C.E

Miracle Educational Society Group of Institutions,
 Vizianagaram, AP, India.

Abstract

The paper presents a human following and an obstacle avoiding algorithm for the Bot that provides a service to a marathoner while training. For its working, the Bot should have the abilities of following a human and dynamically avoid the variable positioning obstacles in an unlevelled outdoor surroundings. The Bot detects a human by a transceiver model, speed is controlled using PWM signal concept and the direction is controlled using sensors. To avoid moving obstacles while following a running person, there is a defined definite radius of each obstacle using the relative velocity between the Bot and an obstacle. For easily avoiding obstacles without collision, a dynamic obstacle avoiding algorithm for the Bot is implemented, which directly employs a real-time position between the Bot and it follows the shortest path around the obstacle to avoid it. We verified the feasibility of these algorithms through experimentation in different outdoor environments.

Index Terms— Human detection, Pulse Width Modulation, mobile Bot, obstacle avoidance.

I. INTRODUCTION

A large number of people participate in marathon races and number of marathons are held worldwide annually [1]. Amateur marathoners often have difficulty transporting their personal belongings while they are training for a race. However, if a mobile Bot follows a marathoner and carries necessities such as water, food,

and clothes, amateur marathoners could enjoy their runs more. Additionally, providing a running path on a map that included running distance, time, and speed would be helpful. This Bot is called the —Marathoner Service Bot (MSR) as it provides services to the marathoner. In order to provide the service, the mobile Bot should recognize a running marathoner in a real outdoor environment and follow the target person at human running speed (max: 18 km/h or 5 m/s). It is noted that the average speed of a normal amateur marathoner is less than 16 km/h. Till date various human tracking approaches have been developed with most based on visual tracking [2]-[6] and other approaches such as laser range finder-based human tracking [7]-[11], 3-D sensor tracking [12],[13], RGB-D sensor tracking [14], and camera and laser fusion tracking [15]. Most tracking systems or mobile Bots have been designed to operate in indoor environments at human walking speed. A Bot system that not only tracks a human at running speed but also avoids moving obstacles in a cluttered environment has rarely been investigated.

II. HUMAN DETECTION

To detect the human a transceiver system is used. Using this module a Bot can know the position of the specific human. After getting the signal the Bot follows the human. The receiver system is designed to match with the enclosed plastic case transmitter for number of control applications. The compact 433MHz RF module has a range of 45 meters. The receiver

system with integrated decoder is easily connected to relay or microprocessor.

Receiver for enclosed plastic case transmitter (see transmitter XETX02A) XERE02A, CD-R04 (433MHz ASK)



Feature

- Best solution for economical short range RF transmission
- Miniature size of 47 x 20 x 8 mm
- Low power consumption (Typ: 4mA)
- Wide operating temperature range of -10 to +70 degree C

Specification

| | min | typ | max | unit |
|-----------------------|-----|-----|-----|------|
| Operating Voltage | 4 | 5 | 6 | V |
| Current Consumption | 2.7 | 4 | 7 | mA |
| Operating Temperature | -10 | 25 | 70 | °C |
| Reception Frequency | - | *A | - | MHz |
| Sensitivity | - | -95 | - | dBm |

*A Frequency also available at 315MHz and 435MHz

- It is the alternative for short range reliable RF transmission
- Dimension is of 47 x 20 x 8 mm -It consumes low power typically 4 milli ampere.
- Operating temperature ranges from -10 to +70 degree Celsius.
- RF transmission transmission range is >100 meters.
- Designed for automotive application
- It consumes low power typically 10nanoAmpere when there is no transmission.

The transceiver module will transmit the signal to the transceiver module on the Bot and the Bot comes to know where the person is exactly heading and it starts following. Human detection is important as the Bot has to follow a particular person only.

III. HUMAN FOLLOWING

To follow a person, the BOT needs to be able to control its linear velocity and angular velocity. The distance between the BOT and the target person is controlled by the linear velocity to keep the desired safe distance. The angle between the heading direction of the BOT and the direction of the target person with

respect to the BOT local coordinate is controlled by the angular velocity of the BOT. To maintain the desired tracking distance between the BOT and the target, a typical PID control, Fuzzy control [16], adaptive control [17], and robust control [18] can be used. However, a typical proportional controller may be suitable for the marathoner following task. It is well known that applying only a proportional controller does not guarantee settling at the desired value, because steady-state errors are retained. Therefore, we used these steady-state errors as the safe distance between the target marathoner and the BOT.

Transmitter XETX02A (433MHz ASK)



Feature

- Best solution for economical RF transmission (> 45 meters)
- Miniature size designed for automotive application
- Low power consumption (Typ: 10mA when no transmission)
- Wide operating temperature range of -10 to +70 degree C

Specification

| | min | typ | max | unit |
|---|-----|-----|-----|------|
| Operating Voltage | 3.3 | 5 | 10 | V |
| Current Consumption (during transmission) | - | 4 | - | mA |
| Operating Temperature | -10 | 25 | 70 | °C |
| Transmission Frequency | - | *A | - | MHz |
| Data Rate | - | 4 | - | kB/s |
| Transmission Power | - | 10 | - | mW |

*A Frequency also available at 315MHz and 435MHz

The following equation describes the proportional controller applied to the mobile Bot. $v=KPv(Da-Dd)$ where v is the linear velocity of the BOT KPv is the proportional gain Da and Dd denote the actual distance between the BOT and the target and the desired tracking distance, respectively. KPv is an indicator of safety margin since a small KPv results in a large tracking distance. Equation indicates that the linear velocity of the mobile Bot increases as the tracking distance increases and vice versa . By using this fact, the mobile Bot automatically guarantees a longer safe tracking distance as the target moves faster. When the marathoner walks or runs slowly, the BOT maintains a

short tracking distance, and when the marathoner runs fast, the BOT maintains a long tracking distance for safety purpose. Even if the BOT has sufficient acceleration capacity to stop immediately, fast movement of the Bot behind the person may frighten the person. Therefore, we used a proportional controller to ensure maintenance of a safe tracking distance. The main function of the BOT is to follow a marathoner. Therefore, the angle between the heading direction of the BOT and the direction of the marathoner is required to be minimized. For compensating the angle error, a typical PID control is applied to the system. For controlling the speed of the Bot Pulse Width Modulation technique is used using a switch which is attached in the shoe of the marathoner. If the marathoner runs accordingly the pulses generated will be more and the Bot will run faster and if the marathoner walks then accordingly the pulses generated will be less and the Bot runs slowly.

IV. PULSE WIDTH MODULATION

A pulse-width modulation signal is generated with the fluctuating voltage that goes up and down repeatedly. The oldest method of generating the up and down oscillation is with a resistor-capacitor (RC) circuit. This circuit uses RC timing with a diode combination to change the ratio of the on-pulse time to the off-pulse time which is also called as the duty cycle.

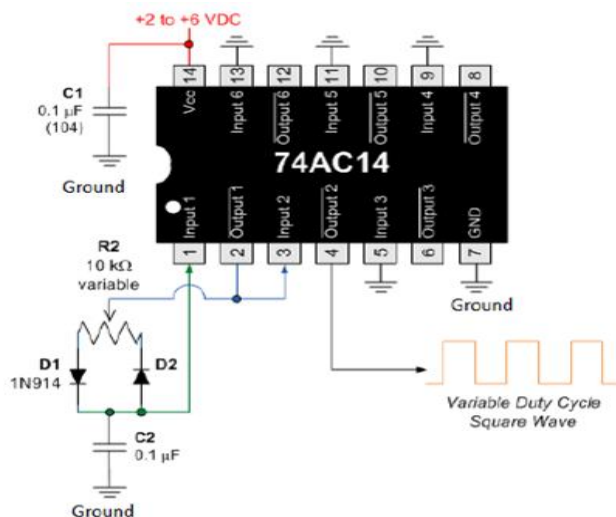

Fig :Pin diagram of changing duty cycle PWM circuit using 74AC14 inverter logic chip

IC1: A 74AC14 Hex Inverter using Schmitt-Trigger Input.

- The number 74xx14 is the standard for a package of six inverter gates connected to particular pins.
- The AC part of the number denotes the technology used to make this chip. In this case, AC stands for Advanced CMOS. The chip working range is from 2V to 6V and it output approximately 25 milli ampere per pin.
- There are six inverter gates available in the packageout of which two of the six inverters is required. The rest can be used for any function or else connect their inputs to ground.
- Inverter means that whatever input is given, the inverse will be output.
- Schmitt-Trigger Inputs are special inputs designed to effectively convert slowly changing analog signals.

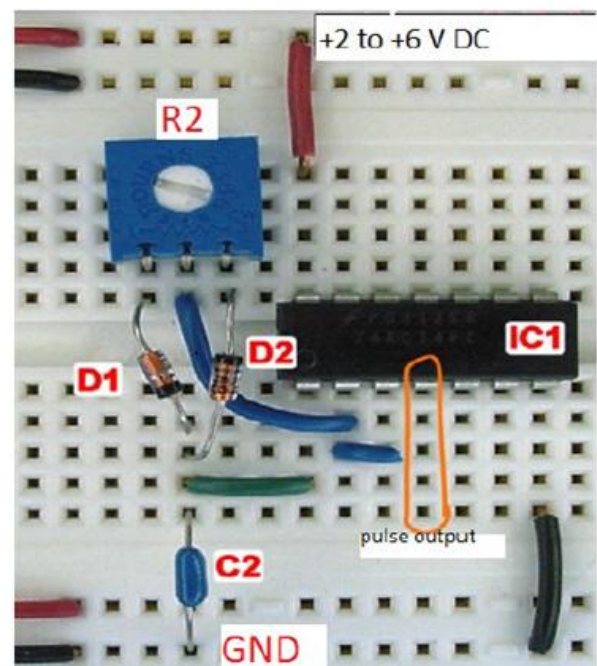

Fig : changing duty-cycle pulse-width modulation circuit board implemented on a breadboard.

C1: A 0.1 µF capacitor smoothens the power supplied to the IC1. If this capacitor was missing, the chip might still work, but there may be some glitches on the input side likewise spikes on the output side.

C2: This 0.1 µF capacitor is going to be charged and discharged continuously to make the pulse wave for PWM. If the capacitance is increased the frequency of the wave will be decreased and vice versa.

R2: A 10 kΩ variable resistor is used to vary the on and off times of the output wave. If the total resistance

value is increased the frequency of the wave is increased and vice versa.

D1 and D2: The diodes like 1N914 or 1N4148 are preferable. Charging is through diode D1 and discharging is through diode D2. The Pulse width would still appear when the diodes are absent, but the on and off times cannot be varied as the capacitor would be charged and discharged through the resistor using the same path.

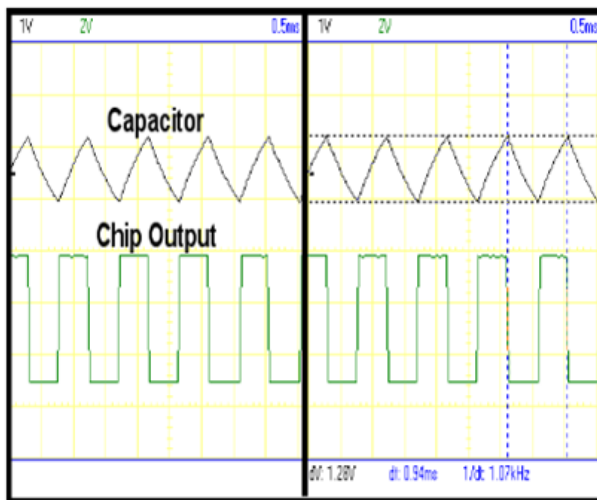

Fig: Oscilloscope graph of a triangular charging –discharging cycle of a capacitor and the square waveform output

Working of PWM

The inverter gate output flips to the opposite of the current state of the capacitor as a result there is a repeated charging and discharging of the capacitor. The output of the inverter charges the capacitor when it is empty and the output discharges it when it is full. Due to this charging and discharging, the output is on for half of the time (when the capacitor is charged) and off for half of the time. Thus it will provide 50 percent power the device that is connected. The reality is that the resistance of the on condition is different from the off condition due to the diodes present. We can make the on time take more or less time than the off time. So we can supply an output signal that is on for almost 0% to 100% of the time. If the output is on for 10% of the time, then the connected device is only going to be on for 10% of the time. Hence, the total power delivered to the connected device is varied simply by tuning the potentiometer to change the duty cycle.

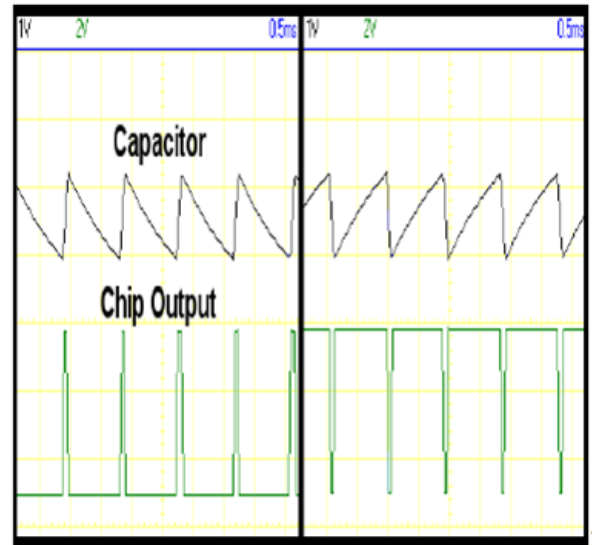

Fig: Trace of a saw tooth charge-discharge cycle of a capacitor and the variable-width PWM square wave output using oscilloscope.

50% PWM Wave is equal to 50% Power

The first graph is a snapshot taken when the potentiometer key is at center. As the same resistance is used for both the charging and discharging condition, the on time and off time is same.

Variable-Width PWM Waves

The second graph is a combined snapshot taken when the potentiometer wiper is first turned highly towards left and then turned right.

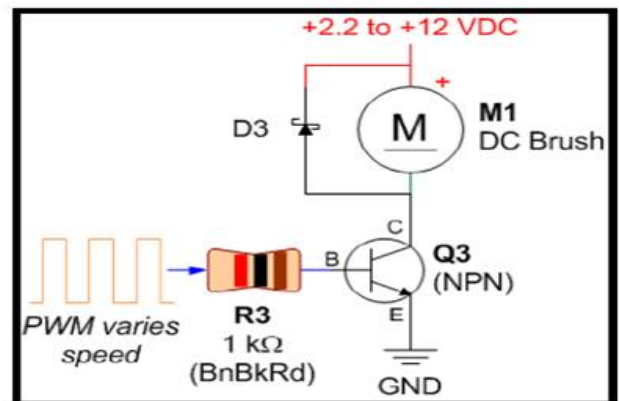

Fig :Circuit Diagram of a pulse-width modulator (PWM)

Speed controlling of the motor using PWM

The motor's speed can be controlled by the duty cycle of the square wave by replacing the variable resistor with a transistor. Pulse-width modulation is a method for adjusting the amount of power delivered to an electrical load which is effective enough.

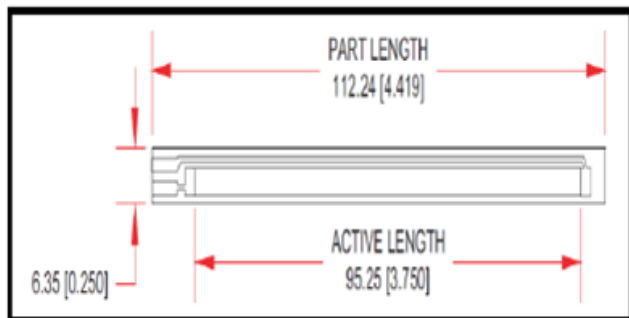
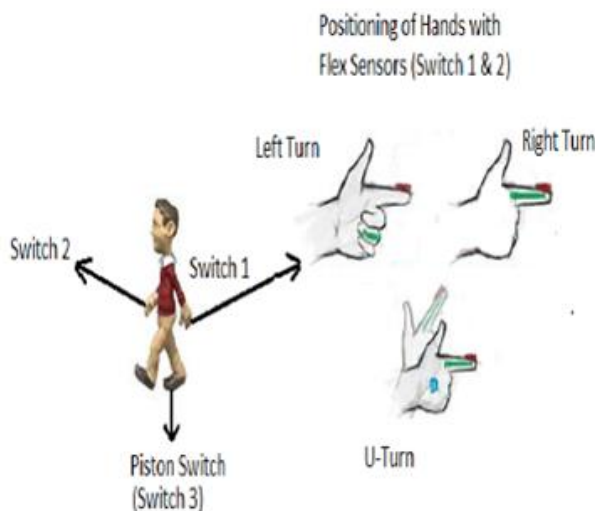

Fig :Dimensional diagram of flex sensor

The above figure shows that the motor can achieve 12V though the 74AC14 logic chip is only powered by 5V. This is due to the logic chip output which feeds into the resistor of the transistor, but not directly effect the motor. The elements like resistor, transistor, and diodes help to isolate the logic voltages from the motor voltages.



V. DIRECTION CONTROLLING

To control the direction of the Bot for moving left and right flex sensors are used .the flex sensors are placed on index fingers of both the hands . When the index finger of right hand is opened wide the Bot moves to the right side and when the index finger of left hand is opened wide the Bot moves to the left side .

The person has to indicate the Bot when he is switching to any direction. Accordingly the Bot with some precalculated delay will turn towards the particular direction indicated.

Flex sensors are those sensors that cause change in the resistance value depending on the variable bending in the sensor. They convert this change in sensor due to bending to electrical resistance –the more the bend the more the resistance value._ It has life cycle which is greater than 1 million. It works efficiently in the Temperature Range which varies between -35°C to +80°C. It provides Resistance Tolerance near about ±30%. It has Bending Resistance which is ranging between 60K to 110K Ohms.

VI. OBSTACLE AVOIDANCE

To use the bot in a real application, the Bot should not only follow a marathoner, but also avoid other objects and people for safety purpose. Obstacle avoiding algorithm for a Bot that moves at a human running speed should consider the motion of the Bot and the objects in the environment [19],[20] .Therefore, to ensure safety, we developed an obstacle avoidance algorithm that takes into account the velocity of obstacles relative to the bot. For the marathoner following task, we assumed that the marathoner runs on a flat paved road or a jogging track.

VII. CONTROL ALGORITHM

1. Target setup
2. Human detection
3. Data collection from sensors
4. Follows the human
5. Check for obstacles
6. Avoid the obstacle based on sensor detection
7. Continues to follow human

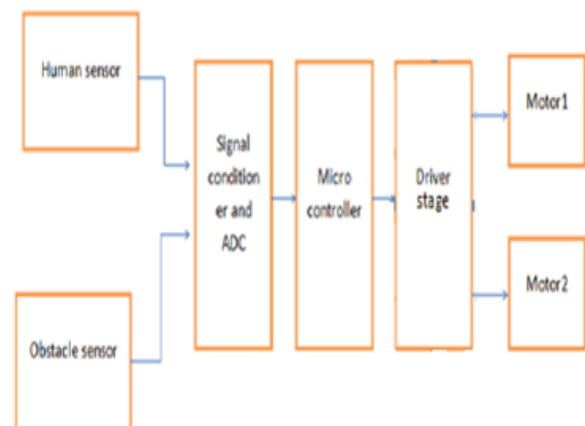

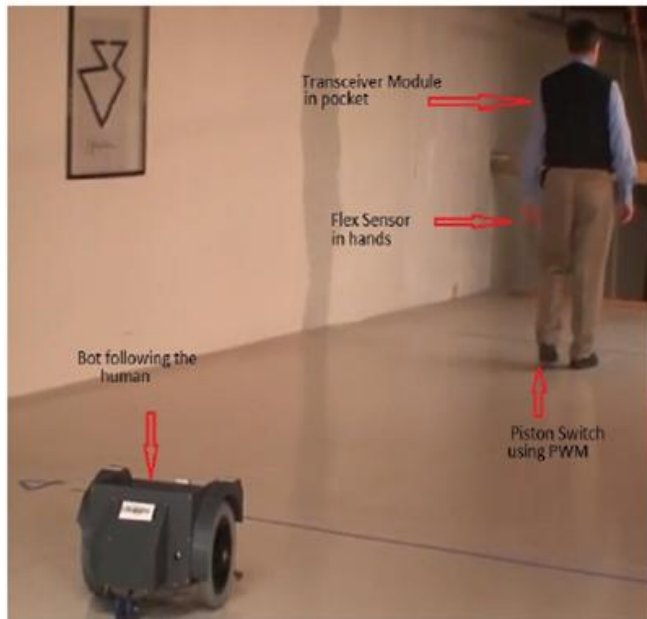

IX. CONCLUSION

We investigated a marathoner Bot system moving at a human running speed. The first contribution is from the transceiver model which helps to follow the human in an unstructured environment. The second contribution is the implementation of a definite radius, which helps the BOT to avoid moving obstacles by considering the relative velocity between the BOT and the nearest obstacle. The last contribution is the integration of the core technologies like PWM and flex sensors mentioned above and applying them to the Bot. We tested the marathoner Bot by making it follow a marathoner and it showed positive results with proper speed control, direction control and obstacle avoiding. Our future work involves upgrading the mechanical strength of our Bot to carry more luggage and upgrading the software algorithms for enhanced safety and making it fully automatic.

X. REFERENCES

[1] Marathon World. (2012). [Online]. Available: <http://www.marathonworld.Com>

[2]] I. J. Cox and S. L. Hingorani, —An efficient implementation of Reid’s multiple hypothesis tracking algorithm and its evaluation for the purpose of visual tracking,|| IEEE Trans. Pattern Anal. Mach. Intell., vol. 18, no. 2, pp. 138–150, Feb. 1996.

[3]] J. K. Aggarwal and Q. Cai, —Human motion analysis: A review,|| in Proc. IEEE Proc. Nonrigid Articulated Motion Workshop, 1997, pp. 90–102. JUNG et al.: DEVELOPMENT OF A LASER RANGE FINDER-BASED HUMAN TRACKING AND CONTROL ALGORITHM 1975

[4] J. Mac Cormick and A. Blake, —A probabilistic exclusion principle for tracking multiple objects,|| in Proc. 7th IEEE Int. Conf. Comput. Vision, 1999, pp. 572–578.

[5] C. Rasmussen and G. D. Hager, “Probabilistic data association methods for tracking complex visual objects,|| IEEE Trans. Pattern Anal. Mach. Intell., vol. 23, no. 6., pp. 560–576, Jun. 2001.

[6] B. Jung and G. S. Sukhatme, —Detecting moving objects using a single camera on a mobile robot in an outdoor environment,|| in Proc. 8th Conf. Intell. Auton. Syst., 2004, pp. 980–987.

[7] B. Kluge, C. Kohler, and E. Prassler, —Fast and robust tracking of multiple moving objects with a laser range finder,|| in Proc. IEEE Int. Conf. Robot. Autom., 2001, pp. 1683–1688.

[8] A. Fod, A. Howard, and M. A. J. Mataric, —A laser-based people tracker,|| in Proc. IEEE Int. Conf. Robot. Autom., 2002, pp. 3024–3029.

[9] H. Zhao and R. Shibasaki, —A novel system for tracking pedestrians using multiple single-row laser-range scanners,|| IEEE Trans. Syst., Man Cybern., A, Syst. Humans, vol. 35, no. 2, pp. 283–291, Mar. 2005.

[10] J. H. Lee, T. Tsubouchi, K. Yamamoto, and S. Egawa, —People tracking using a robot in motion with laser range finder,|| in Proc. IEEE/RSJ Int. Conf. Intell. Robots Syst., 2006, pp. 2492–6392.

[11] K. O. Arras, O. M. Mozos, and W. Burgard, —Using boosted features for the detection of people in 2D range data,|| in Proc. IEEE Int. Conf. Robot. Autom., 2007, pp. 3402–3407.

[12] R. Urtasun, D. J. Fleet, and P. Fua, —3D People tracking with Gaussian process dynamical models,|| in

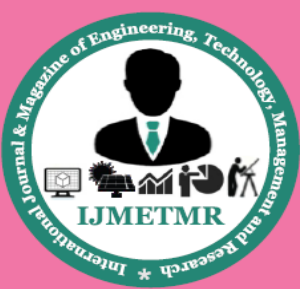

Proc IEEE Comput. Soc. Conf. Comput. Vision
Pattern Recognit., 2006, pp. 238–245.

[13] L. Spinello, M. Luber, and K. O. Arras,
—Tracking people in 3D using a bottom-up top-down
detector, in Proc. IEEE Int. Conf. Robot. Autom.,
2011, pp. 1304–1310.

[14] C. Wongun, C. Pantofaru, and S. Savarese,
—Detecting and tracking people using an RGB-D
camera via multiple detector fusion, in Proc. IEEE
Int. Conf. Comput. Vision Workshops, 2011, pp. 1076–
1083.

[15]] M. Kobilarov, G. Sukhatme, J. Hyams, and P.
Batavia, —People tracking and following with mobile
robot using an omnidirectional camera and a laser, in
Proc. IEEE Int. Conf. Robot. Autom., 2006, pp. 557–
562.

[16] K. Tanaka, M. Tanaka, H. Ohtake, and H. O.
Wang, —Shared nonlinear control in wireless-based
remote stabilization: A theoretical
approach, IEEE/ASME Trans. Mechatronics, vol. 17,
no. 3, pp. 443–453, Jun. 2012.

[17] Y. Bin, H. Chuxiong, and W. Qingfeng, —An
orthogonal global task coordinate frame for contouring
control of biaxial systems, IEEE/ASME Trans.
Mechatronics, vol. 17, no. 4, pp. 622–634, Aug.
2012.