

Effective Ways to Use Internet of Things in the Field of Medical and Smart Health Care



K.E. Vimala

M.Tech,

St. Peters Engineering College,
Hyderabad, India.



P. Madhuri

Assistant Professor,

St. Peters Engineering College,
Hyderabad, India.

Abstract:

The recent advancements in technology and the availability of the Internet make it possible to connect various devices that can communicate with each other and share data. The Internet of Things (IoT) is a new concept that allows users to connect various sensors and smart devices to collect real-time data from the environment.

The design and implementation of an IOT-based health monitoring system for emergency medical services which can demonstrate collection, integration, and interoperation of IoT data flexibly which can provide support to emergency medical services like Intensive Care Units(ICU).

Existing System

This project describes the design of a simple, low-cost microcontroller based heart rate with LCD output. Heart rate of the subject is measured from the thumb finger using IRD (Infra Red Device sensors and the rate is then averaged and displayed on a text based LCD.). The device LCD displaying the heart beat rate and counting values through sending pulses from the sensor.

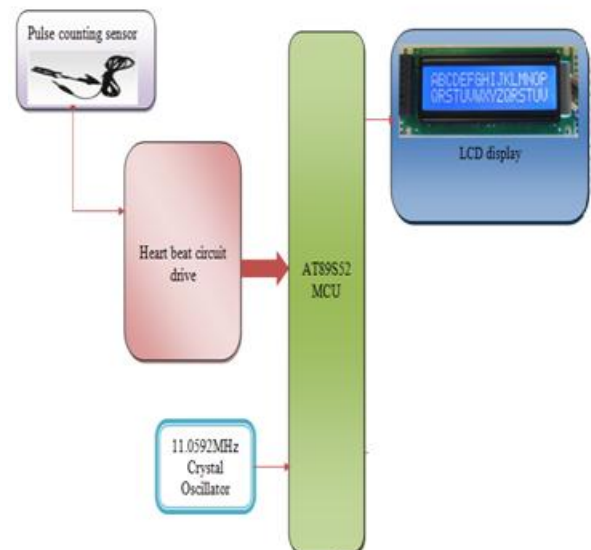

Drawback

There are no modules of BP and ECG. Remote monitoring is also not available.

Proposed System

This project describes the design of a simple, low-cost controller based patient health monitoring system. Heart rate of the subject is measured from the thumb finger using IRD (Infra Red Device sensors). This instrument employs a simple Opto electronic sensor, conveniently strapped on the finger, to give continuous indication of the pulse digits. We also have a Blood pressure sensor to have the knowledge of BP of the patient. A tilt sensor is included to know whether the patient is stable or not. ECG output can be shown in the PC.

This project uses LPC2148 as its controller. By reading the values of heart rate controller will display on LCD. Heart beat values will be taken and updated in the web server about the condition of the patient using IoT module interfaced to the controller. The proposed model enables users to improve health related risks and reduce healthcare costs by collecting, recording, analyzing and sharing large data streams in real time and efficiently.

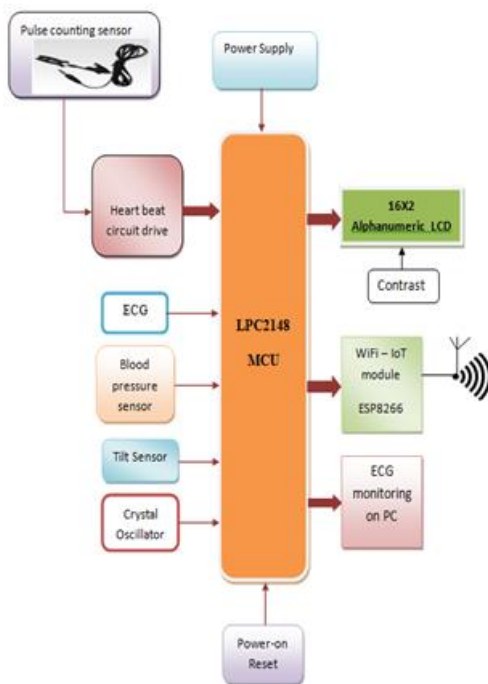

Modules used in this project

The **LPC2148** are based on a 16/32 bit ARM7TDMI-ST[™] CPU with real-time emulation and embedded trace support, together with 128/512 kilobytes of embedded high speed flash memory. A 128-bit wide memory interface and unique accelerator architecture enable 32-bit code execution at maximum clock rate. For critical code size applications, the alternative 16-bit Thumb Mode reduces code by more than 30% with minimal performance penalty. With their compact 64 pin package, low power consumption, various 32-bit timers, 4- channel 10-bit ADC, USB PORT, PWM channels and 46 GPIO lines with up to 9 external interrupt pins these microcontrollers are particularly suitable for industrial control, medical systems, access control and point-of-sale.

With a wide range of serial communications interfaces, they are also very well suited for communication gateways, protocol converters and embedded soft modems as well as many other general-purpose applications.

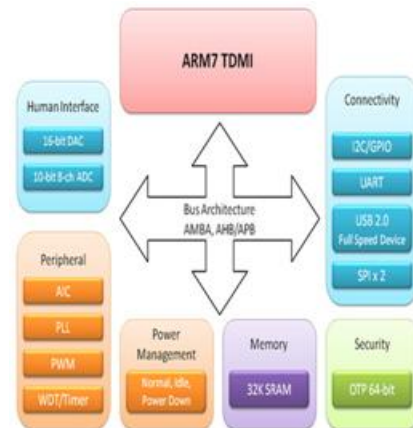

ARM PROCESSOR

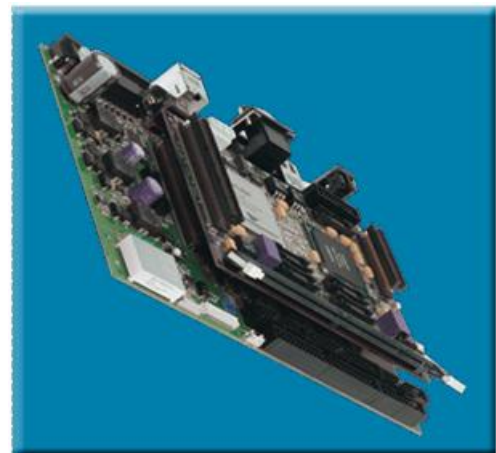

ARM7TDMI Processor Core

- Current low-end ARM core for applications like digital mobile phones
- TDMI
 - T: Thumb, 16-bit compressed instruction set
 - D: on-chip Debug support, enabling the processor to halt in response to a debug request
 - M: enhanced Multiplier, yield a full 64-bit result, high performance
 - I: Embedded ICE hardware
- Von Neumann architecture

Blood Pressure Meter

A sphygmomanometer (blood pressure meter, or blood pressure gauge (also referred to as a sphygmometer) is a device used to measure blood pressure, composed of an inflatable cuff to restrict blood flow, and a mercury or mechanical manometer to measure the pressure. It is always used in conjunction with a means to determine at what pressure blood flow is just starting, and at what pressure it is unimpeded. Manual sphygmomanometers are used in conjunction with a stethoscope. The word comes from the Greek (sphygmos, pulse), plus the scientific term manometer (pressure meter). The device was invented by Samuel Siegfried Karl Ritter von Basch in 1881. Scipione Riva-Rocci introduced a more easily used version in 1896. In 1901, Harvey Cushing modernized the device and popularized it within the medical community. A sphygmomanometer consists of an inflatable cuff, a measuring unit (the mercury manometer, or aneroid gauge), and a mechanism for inflation which may be a manually operated bulb and valve or a pump operated electrically. The usual unit of measurement of blood pressure is millimeters of mercury (mmHg) as measured directly by a manual sphygmomanometer.



Pulse Counting Sensor

Heart rate is the speed of people's emotional state, exercise intensity and objective indicator of cardiac function. But most people are very difficult to accurately measure the time and his heart rate values. If the heart rate monitor with me, heart ECG electrodes will be detected by monitoring the signal processing device, the user can at any time that your heart rate changes, changes in heart rate, self-monitoring status.

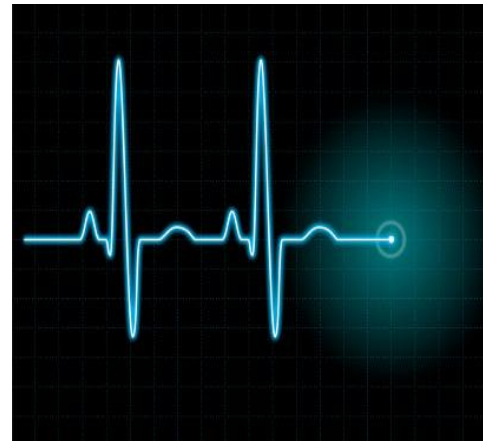

Heart rate monitor for heart rate range (60 ~ 160) / min. Circuit by adjusting the relevant components, in the (60 ~ 160) / min within the audible alarm can change the heart rate range. This heart rate range the width of the design center values $\pm 20\%$ range. If central values such as emphasis on the 100 / exceptionally, the heart rate signal range (80 ~ 120) / min, if the heart rate exceeds this range, the lower limit, the instrument does not sound, if the heart rate in the range of the instrument ECG is the sound issue.

ECG



Directly connects to dry electrode (as opposed to conventional medical wet sensors)

- One EEG channel with three contacts: EEG; REF; and GND
- Improper fit detected through “Poor Signal Quality” warning from ASIC to reset if off the head for four consecutive seconds, or if it is receiving a poor signal for seven consecutive seconds
- Advanced filtering technology with high noise immunity
- Low power consumption suitable for portable battery-driven applications
- Max power consumption 15mA @ 3.3 V
- Raw EEG data output at 512 bits per second

INTERNET OF THINGS

Internet is helping people to communicate each other using different applications

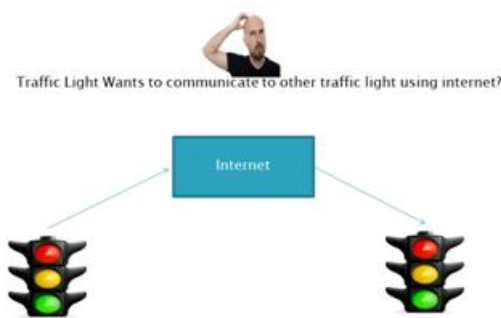

Internet of things helps the things to communicate each other using IoT module

ESP8266EX

▶ The Internet of Things (IoT) is the network of physical objects or "things" embedded with electronics, software, sensors, and network connectivity, which enables these objects to collect and exchange data.



Wi-Fi Module

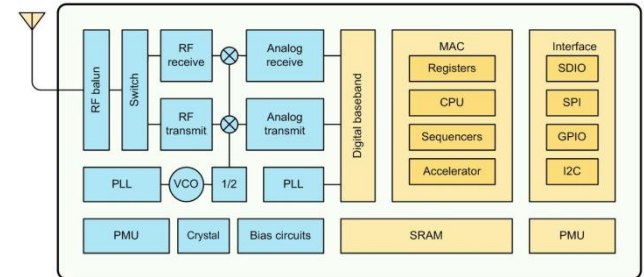

ESP8266EX offers a complete and self-contained WiFi networking solution; it can be used to host the application or to offload WiFi networking functions from another application processor. When ESP8266EX hosts the application, it boots up directly from an external flash. It has integrated cache to improve the performance of the system in such applications. Alternately, serving as a WiFi adapter, wireless internet access can be added to any micro controller-based design with simple connectivity (SPI/SDIO or I2C/UART interface).

Software Tools

Keil compiler is a software used where the machine language code is written and compiled. After compilation, the machine source code is converted into hex code which is to be dumped into the microcontroller for further processing. Keil compiler also supports C language code.

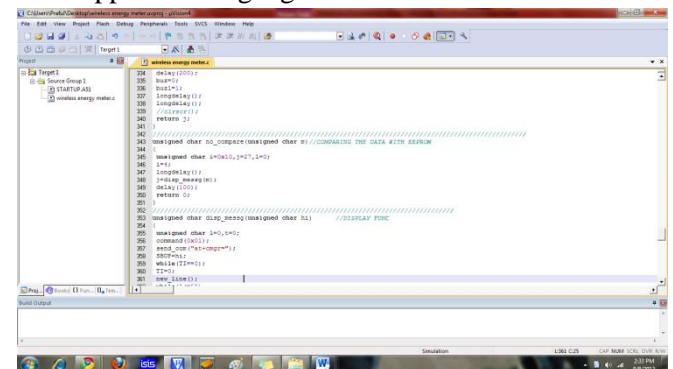

Flash Magic

Flash Magic is a tool which is used to program hex code in EEPROM of micro-controller. It is a freeware tool. It only supports the micro-controller of Philips and NXP.

It can burn a hex code into that controller which supports ISP (in system programming) feature. Flash magic supports several chips like **ARM Cortex M0, M3, M4, ARM7 and 8051**.



Advantages

- Ease of operation
- Low maintenance cost
- Fit and forget system
- No wastage of time
- Durability
- Accuracy

Applications

- Hospitals
- Remote heart rate monitoring applications
- Body temperature Monitoring
- Local monitoring applications
- Designed for Home and Clinical Applications

Future Scope

Video monitoring could be used for monitoring patients

Result of our project displaying normal heart rate



Conclusion

Here we have designed a simple, low-cost controller based wireless A Wireless Tracking System for At-home Medical Equipment during Natural Disasters

References:

- [1] Braunwald E. (Editor), Heart Disease: A Textbook of Cardiovascular Medicine, Fifth Edition, p. 108, Philadelphia, W.B. Saunders Co., 1997. ISBN 0-7216-5666-8.
- [2] Van Mieghem, C; Sabbe, M; Knockaert, D (2004). "The clinical value of the ECG in no cardiac conditions" *Chest* 125(4):156176. Doi:10.1378/chest.125.4.1561. PMID 15078775.
- [3] "2005 American Heart Association Guidelines for Cardiopulmonary Resuscitation and Emergency Cardiovascular Care -Part 8: Stabilization of the Patient With Acute Coronary Syndromes." *Circulation* 2005; 112: IV-89-IV-110.
- [4] A. R. Houghton and D. Gray., "Making sense of the ECG", Hodder Arnold Publishing's 2003.
- [5] Forerunner 201/301 User Guide, web site: <http://www.grmin.com>.
- [6] Pulsar heart rate monitors, web site: <http://www.heartratemonitor.co.uk>.
- [7] David A. Bell, "Operational amplifiers and linear ICs", 2nd Edition, Oxford University Press, 1997.
- [8] Kenneth.J.Ayala,"The 8051 Microcontroller Architecture programming and Applications", 2nd Edition.
- [9] Janicegillispie Mazidi, Muhammad Ali Mazidi,"The 8051Microcontroller and Embedded System", 2nd Edition, Person Education 2009.
- [10] Webster John G.," Medical Instrumentation. Application and Design", 3rd Edition Wiley, 1998.
- [11] Ramakant A. Gayakwad, "Op-amps and linear integrated circuits", 2nd Edition Prentice Hall, 2000.



[12] ECG Measurement System -Chia-Hung Chen,
Shi-Gun Pan, Peter Kinget.

[13] Daniel Paulus / Thomas Meier,"ECG-Amplifier",
MB Jass 2009.

[14] G.M.Patil, K.Subbarao, V.D.Mytri, A.D. Raj
kumar, D.N.Reddy and K. "Embedded Microcontroller
based Digital Telemonitoring System for ECG", J.
Instrum.Soc. India 37(2) 134-149.

[15] Dr. P. K. Dash, "Electrocardiogram Monitoring",
Indian J.Anaesth. 2002; 46 (4): 251-256.