

## **Interconnection of PV and PMSG based Wind Energy Conversion System to Grid**

**A.D.Padma**

**M.Tech Student Scholar,  
Department of Electrical & Electronics Engineering,  
Scient Institute of Technology,  
Ibrahimpatnam, RR.dist.Telangana, India.**

**Mr.M.Ugender Reddy**

**Assistant Professor,  
Department of Electrical & Electronics Engineering,  
Scient Institute of Technology,  
Ibrahimpatnam, RR.dist.Telangana, India.**

### **Abstract:**

This paper proposes a hybrid renewable energy conversion system uses a power converter topology with permanent magnet synchronous generator integrated with stand alone and grid connected operations. The configuration consists of a diode rectifier, a buck converter and a voltage source inverter (VSI). The advantage of using diode rectifier is that it provides a low cost solution to convert ac power into dc. A PMSG feeds an isolated load through a closed loop boost converter. The output voltage and frequency of the PMSG is variable in nature due to non uniform wind velocities and is not synchronized with the grid frequency. In order to condition and feed it to grid we need power electronic interface. In this system the PMSG output is converted to variable DC using a diode full bridge rectifier and converted to constant DC using a closed loop boost converter. The variable ac output is rectified by a diode rectifier and maintained constant by a boost converter. The converter output is fed to three phase inverter which employs a sine PWM technique, the output of which is fed to the load. The power converters and together with independent control systems can effectively improve the output voltage and frequency of the wind PMSG feeding an isolated load. The whole system is simulated by using MATLAB/ Simulink.

### **Key words:**

Three phase diode bridge rectifier, Photo voltaic system, Fuel cell system, Permanent magnet synchronous generator (PMSG) .

### **I.INTRODUCTION:**

In recent years, due to the fast depleting conventional energy resources and the concerns over climatic changes, the renewable energy sources are gaining popularity around the globe.

Among the available renewable energy sources, the wind energy and the solar energy are the most mature technologies for power generation. The main advantage of renewable energy is that it is clean and inexhaustible. But the major disadvantage is that it is interim in nature and depends on seasonal pattern [1]. Therefore it is difficult to operate the power system only with renewable energy due to their characteristic difference and their uncertainty of availability. The potential of renewable energy sources is fully extracted by interfacing them to the existing grid. The main drawback of Wind is its irregularity in occurrence and how to maximize the energy generation from wind. The wind energy can be harnessed by a wind energy conversion system (WECS), composed of a wind turbine, an electric generator, a power electronic converter and the corresponding control system.

Various WECS structures could be realized from the several categories of available components. However, the main objective of every structure is same that is conversion of Wind energy at varying wind velocities into the grid frequency of electricity. With special reference to the speed, two main classes are recognized for the generators of wind power application that are constant and variable speed generators. The constant speed wind turbines and induction generators were often used, in the early stages of wind power development. Some of the disadvantages of fixed speed generators are the low efficiencies, poor power quality, high mechanical stress including a runtime issue that is maximum coefficient of performance could be obtained only at a particular Wind speed.

Now a day's variable speed operations became more attractive because of the development of power electronics and falling cost of component and technology as well [2]. By running the wind turbine generator in variable speed, variable frequency mode, and the maximum power could be extracted at low and medium wind speeds. Among all kinds of wind energy conversion systems (WECSs), a

variable speed wind turbine (WT) equipped with a multi pole permanent magnet synchronous generator (PMSG) is found to very attractive and suitable for the application in large wind farms. With gearless construction of such PMSG, advantages like low maintenance, reduced losses and costs, high efficiency and good controllability could be derived [3]. This paper presents an efficient hybrid renewable energy conversion system using PMSG and power electronic converters connected to grid. In this system the PMSG output is converted to variable DC using a diode full bridge rectifier and converted to constant DC using a closed loop boost converter. This constant DC output is converted to AC using a Sine PWM three phase inverter and it is fed to the load.

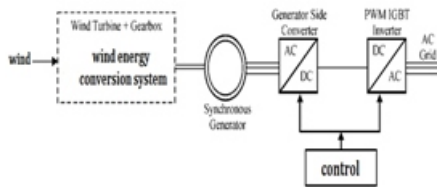
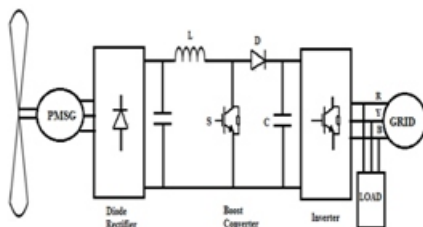

**Fig. 1. Proposed Wind Energy Conversion System**

## II. DESCRIPTION OF THE PROPOSED SYSTEM:

### A. Block diagram of the proposed system:

The wind turbine is the prime mover of the Permanent magnet synchronous generator. As the wind velocity is non uniform in nature, the output of PMSG will be fluctuating. Therefore it cannot be interfaced directly to the load. The output of PMSG is converted to DC using a full bridge rectifier and the variable DC is converted to constant DC by a closed loop Boost converter. This constant DC output is converted to AC using an inverter. This inverter is operated with Sine PWM technique and fed to the load.



**Fig.2. Block diagram of the system.**

### B. Permanent Magnet Synchronous Generator:

The PMSG is a Synchronous Machine, where the DC excitation circuit is replaced by permanent magnets, by eliminating the brushes.

PMSG has a simple design, robust, smaller physical size, a low moment of inertia which means a higher reliability and power density per volume ratio as it has permanent magnets instead of brushes and the slip rings. Also by having permanent magnets in the rotor circuit, the electrical losses in the rotor are eliminated. The PMSG are becoming an interesting solution for wind turbine applications.[4] However, the disadvantages of the permanent magnet excitation are high costs for permanent magnet materials and a fixed excitation, which cannot be changed according to the operational point. The Permanent magnet synchronous generators are being used in many small generating systems, particularly wind power system. The PMSG is typically constructed with magnets attached to the rotor and a three phase winding in the stator core. PMSG do not require an additional DC supply for the excitation circuit [5]. Furthermore the mechanical friction is low in comparison to other machines because there is no brush gear and does not require a gear box. These are lighter and therefore high power to weight ratio. Unlike Induction generators these do not require reactive magnetizing current for excitation. However PMSG have these advantages, the negative side is that the permanent magnets required for PMSG are quite expensive, at high temperatures the magnets get demagnetized.

### C. Three phase diode rectifier:

The diode rectifier is the most simple, cheap, and rugged topology used in power electronic applications. The most disadvantage of this diode rectifier is its disability to work in bi-directional power flow. The variable output dc voltage from three-phase diode bridge rectifier can be obtained. Fig.3. Three phase diode bridge rectifier.

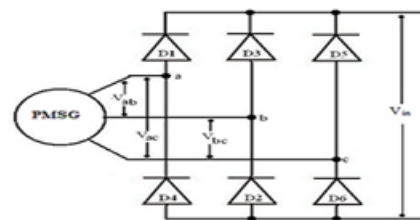

**Fig.3. Three phase diode bridge rectifier**

### D. Boost converter:

A boost converter (step-up converter) is a power converter with an output DC voltage greater than its input DC voltage.

It is a class of switching-mode power supply (SMPS) containing at least two semiconductor switches (a diode and a transistor or a MOSFET or an IGBT or a BJT) and at least one energy storage element. Fig.4. Basic schematic diagram of boost converter A process that changes one DC voltage to a different DC voltage is called DC to DC conversion. A boost converter is a DC to DC converter (Fig. 4) with an output voltage greater than the source voltage.

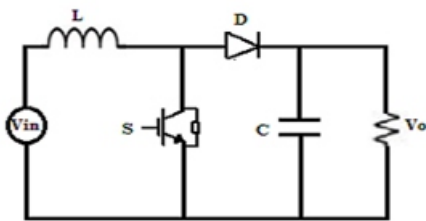

Fig.4. Basic schematic diagram of boost converter

A boost converter is sometimes called a step-up converter since it “steps up” the source voltage. The output voltage of the boost converter is given by

$$\frac{V_o}{V_{in}} = \frac{1}{(1-d)} \quad (1)$$

$V_{in}$  = input voltage of boost converter  
 $V_o$  = output voltage of boost converter  
 $d$  = duty cycle

### E. Closed Loop Boost converter:

The closed system of boost converter is obtained by using a Voltage mode PWM Scheme. The block diagram of which is shown in the figure 5. In this technique the output of the boost converter is kept constant by using the duty ratio as the control variable.

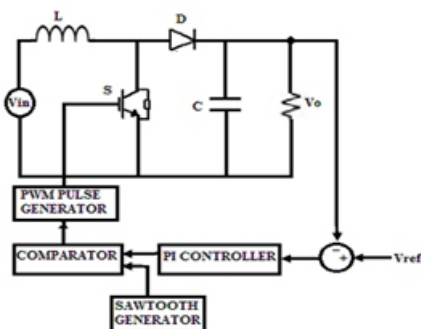

Fig.5. Closed loop boost converter

The error amplifier compares the output voltage  $V_o$  with the reference voltage and generates the error signal. This error signal is given as the input to the PI controller. The output of the PI controller is compared with the saw-tooth signal and the pulses are generated [6],[7]. The output pulses are functions of duty cycle. The boost converter operate in Continuous conduction mode for  $L > L_b$ , where

$$L_b = \frac{(1-d)^2 dR}{2f} \quad (2)$$

The value of the filter capacitor required is more to limit the output voltage ripple. The minimum value of filter capacitor needed is given by

$$C_{min} = \frac{dV_o}{V_r R f} \quad (3)$$

Where  $d$  is the duty ratio  
 $f$  is the switching frequency  
 $R$  is the load resistor  
 $V_r$  is the ripple voltage

Using the above design equations, the boost converter is designed for the proposed application with  $V_{in} = 200$  V;  $V_o = 500$  V;  $d = 0.6$ ;  $f = 5$  kHz;  $R = 250\Omega$ ;  $V_r = 1\%$ ; The values of  $L_b$  obtained is  $L_b = 2.4$  mH; It is rounded off to 3 mH;  $C_{min} = 0.48$   $\mu$ F; It is rounded off to 10 $\mu$ F; With these values of  $L$ ,  $C$  and  $d$ , the transfer function of the boost converter is derived using state space averaging scheme. The transfer function derived is

$$\frac{X_1(s)}{U_1(s)} = \frac{13.33e^{-6}}{s^2 + 400s + 5.33e^6} \quad (4)$$

$X_1(s)$  is the  $s$  domain representation of the output voltage and  $U_1(s)$  is the  $s$  domain representation of the input voltage of the boost converter. With the derived transfer function the PI controller was designed using Ziegler Nichols tuning method [8]. In this method of tuning the step response of the system transfer function is obtained, which is a S shaped curve. On the curve the point of inflection is noted and a tangential line is drawn.

The point at which this tangent touches the time axis gives the value of  $L$ , the point at which it touches the projection of the steady state value is noted and the corresponding time is noted. The difference value between this value of time and  $L$  is taken as  $T$ . The  $K_p$  and  $K_i$  values of the controller are decided using the following equations.



$$\begin{aligned}
 K_p &= 0.9 \frac{T}{L} \\
 T_i &= \frac{L}{0.3} \\
 K_i &= \frac{K_p}{T_i}
 \end{aligned}
 \tag{5}$$

The values obtained for the given transfer function are  $K_p=0.0008$ ;  $K_i=0.008$ .

### F. Three phase inverter:

An inverter is a circuit that converts DC to AC. Pulse Width Modulation (PWM) is a switching technique that is used to decrease the total harmonic distortion in the inverter circuit. The output of the boost converter is fed to a three phase inverter which converts the constant DC to constant AC having a frequency of 50 Hz. The objective in pulse-width modulated three-phase inverters is to shape and control the three-phase output voltages in magnitude and frequency with an essentially constant input voltage  $V_o$ . To obtain balanced three-phase output voltages in a three-phase PWM inverter, the triangular voltage waveform is compared with three sinusoidal control voltages that are 120 deg out of phase. The schematic diagram of a three phase inverter is shown in the figure.

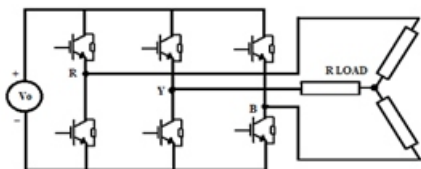

**Fig.5. Three phase inverter**

There are six switches which are operated in a sequence based on the pulses generated by Sine PWM technique. The switches are operated in 120 degree conduction mode. In this mode each transistor conducts for 120 degree. Only two transistors remain ON at any instant of time. The output of the three phase inverter is given to the R load. For realizing Sine PWM, a high frequency carrier wave is compared with a sinusoidal reference wave of desired frequency. The intersection of the two waves determines the switching instants and commutation of the modulated pulse.  $A_c$  is the peak value of the triangular carrier wave and  $A_r$  is the peak value of the modulating signal. The carrier and the reference waves are mixed in a comparator. When the sinusoidal wave has magnitude higher than the triangular wave, the comparator output is high, otherwise it is low. The comparator output is processed in such a manner that the output voltage wave of the inverter has a pulse width agreement with the comparator output pulse width.

### IV. HYBRID ENERGY CONVERSION SYSTEM:

Electricity can be produced by conventional energy sources or by non-conventional energy sources. The conventional energy sources (Oil, Gas, and Coal) are finite and it generates pollution. As the environmental pollution increases, the current policies search for more efficient power generating systems, employing the existing resources in the best way. The alternative energy sources like wind, fuel cell, solar, tidal, etc. available abundant in nature. They have the advantages of sustainability, renewability and pollution reduction.

They can also bring economic benefits to many regional areas that are located away from cities. In recent years, the hybrid generation system has become significant because of the complementary characteristics among the new and renewable energy resources. The fuel cell and solar energy systems are highly unreliable due to their unpredictable nature. When a source is unavailable or insufficient in meeting the load demands, the other energy source can compensate for the difference. So, hybrid system with the combination of solar-fuel cell with backup system is an attractive method to power in remote rural areas.

When neither the fuel cell nor the solar systems are producing, power can be supplied by the batteries and/or a generator powered by conventional fuels, like diesel. If the batteries are low, the diesel generator can provide power and recharge the batteries[9]. The use of a maximum power point tracking technique(MPPT) algorithm is necessary to extract as much power as possible from the solar when its irradiation changes.

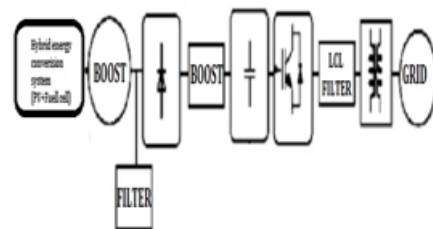

**Fig.6. Hybrid energy conversion system connected to grid**

## IV.SIMULATION RESULTS:

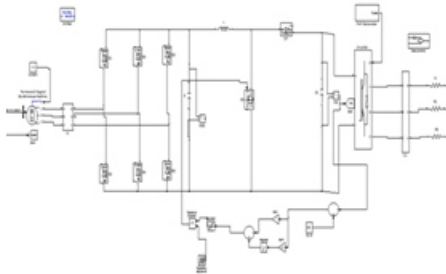

Fig.7. Simulink circuit for proposed system

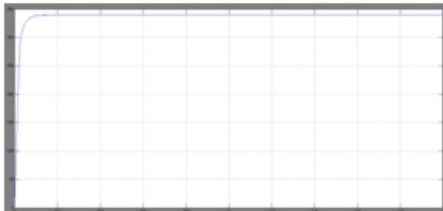

Fig.8.Simulation results for speed of PMSG under constant speed

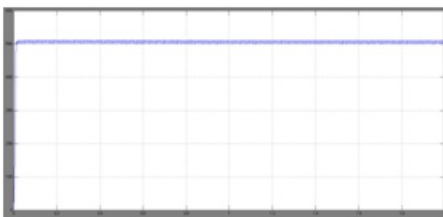

Fig.9. Simulation results for output voltage of boost converter

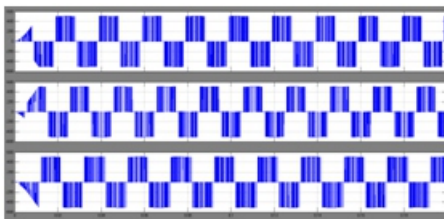

Fig.10. Output voltage in three phases at the load



Fig.11. simulation result for speed of PMSG under variation speed

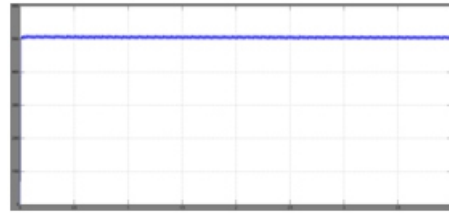

Fig.12. simulation result for output voltage of boost converter

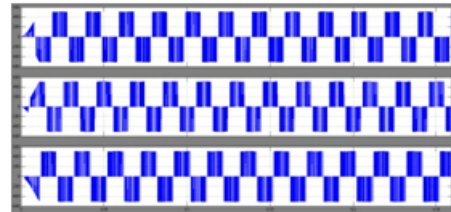

Fig.13. Output voltage in three phases at the load

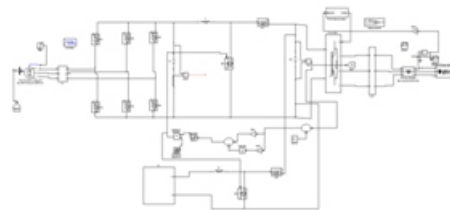

Fig.14. Simulink circuit for hybrid renewable energy sources interacted to grid

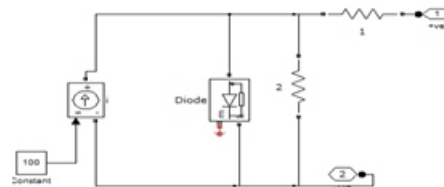

Fig.15. Simulink design for photovoltaic cell

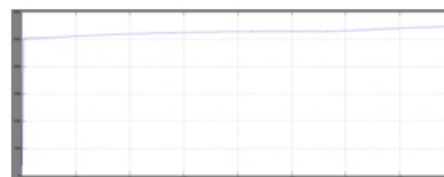

Fig.16. Simulation results for output voltage of boost converter

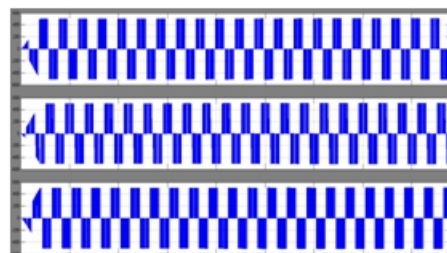
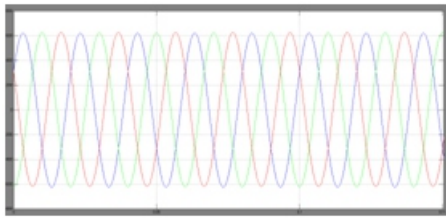

Fig.17. Output voltage in three phases at the load



**Fig.18.Simulation results for grid voltages.**

## V. CONCLUSION:

In this paper, the power electronic topology comprising of diode rectifier, DC to DC boost converter and inverter for a variable hybrid (Pv+Fuel cell) energy conversion system with PMSG for a standalone application is presented. The state space averaging technique employed for obtaining transfer function of the boost converter and the subsequent design of PI controller using Ziegler Nichol's technique for the dc-dc boost converter for maintaining the required dc link voltage constant is given in detail. The analysis and dynamic response with the designed controller is carried out for varying wind speed and load and the simulation results are given to validate the design. Further work can be extended to control the output of inverter in order to maintain the frequency and satisfy the requirements of the grid and to synchronize it with the grid.

## REFERENCES:

- [1] Sannino.A, "Global power systems for sustainable development", IEEE General Meeting, Denver, CO, Jun 2004.
- [2] Haque, M.E., Negnevitsky, M. and Muttaqi, K.M., "A novel control strategy for a variable-speed wind turbine with a permanent-magnet synchronous generator," IEEE Transactions on Industry Applications, , vol. 46, no. 1, pp. 331- 339, Jan/Feb. 2010.

[3] Kumar, V., Joshi, R.R. and Bansal, R.C., —Optimal control of matrix converter based WECS for performance enhancement and efficiency optimization,|| IEEE Transaction of Energy Conversion, vol. 24, no. 1, pp. 264-273, March. 2009.

[4] Pahlevaninezhad, M., Eren, S., Bakhshai, A. and Jain,—A model reference adaptive controller for a wind energy conversion system based on a permanent magnet synchronous generator fed by a matrix converter,|| In proceedings of 35th annual conference of the IEEE Industrial Electronics Society, pp.65-70,2010.

[5] Control and Interfacing of a Grid-Connected Small scale Wind Turbine Generator. Haining Wang, Chem Nayar,Senior member ,IEEE, Jianhui Su, and Ming Ding. IEEE Transactions on energy conversion, Vol.26,No 2, June 2011.

[6] Power Switching converters , Simon Ang, Alejandro Oliva

[7] Power Electronics Hand book , M.H.Rashid, Academic Press, 2001

[8] Modern Control Engineering, Fifth edition, Katsuhiko Ogata, PHI Learning Private Limited, 2011.

[9] B.Mangu, K.Kiran Kumar and B.G.Fernandes, "Efficiency improvement of Solar-Win based Dual input converter for telecom power supply", EEIC, 11th International Conference, pp.914-919, 2012.