

Implementation of Fuzzy Based Ac/Dc Grid Side Voltage Source Converter Utilized in Wind Power Generation Systems.

Devanand.Pillala

M.Tech Student,
Dept. of EEE
Gokul Group Of Institutions
Bobbili, A.P, India.

R.Srinivas Rao

Assistant Professor
Dept. of EEE
Gokul Group Of Institutions
Bobbili, A.P, India.

Abstract

The AC/DC grid side voltage source converter dominance features are used to associate with grid and wind power system. Grid side voltage source converter plays a substantial role for the overall grid performance. To influence the grid side dc voltage and system power factor we are used Voltage oriented controlled PI and Phase Locked Loop (PLL) according to the decoupled control theory. The dominance scheme and mathematical models of grid side converter are examined accordingly wind power generation system. MatLab Sim Power System utilized to evaluate the overall features and the dominance operation of grid side converter. The grid side converter controller and the grew dominance mechanism is executable or not for grid-side converter accordingly wind power generation system is asserted in MatLab SimPower System. The new fuzzy system will result in high reliability, low cost and better utilization of resources available.

Index Terms— Fuzzy Controller, Voltage oriented controlled PI, Grid side voltage source converter, wind power generation system, Mamdani's fuzzy inference method.

1.INTRODUCTION

1. Day By Day Energy Requirements Are Increasing And Electrical Utility Is Concerned About Meeting The Growing Energy Demand. Almost 70percent Of The Energy Requirements Are Satisfied By Fossil Fuels. Since They Are On The Path Of Extinction And It Is Associated With Air Pollution, Global Warming And Increase In Cost, It Has Become Necessary To Utilized Renewable Sources For Satisfying Our Energy Requirements. Wind Energy Is The Fastest

Growing And Most Promising Renewable Energy Source Among Them Due To Economically Viable. In India, The Total Installed Capacity Of Wind Power Generation Is 8754 Mw In The Year 2008.By The End Of 2012, The Total Installed Capacity Is Going To Be Reached To 12000 Mw According To Ministry Of New And Renewable Energy, India And Total Installed Capacity Of Wind Energy Is Estimated To Be More Than 160 Gw [Wwea] All Around The World. The First Production Of Electrical Energy With Wind Power Was Done In 1887 By Charles Brush In Cleveland, Ohio [2-3]. During Last Two Decades, The High Penetration Of Wind Turbines In The Power System Has Been Closely Related To The Advancement Of The Wind Turbine Technology And The Way Of How To Control. Wind Energy Has Been Intensively Analyzed In Late Years In Many Different Countries, Which Resulted In Several Different Forms Like Fixed Speed System With A Squirrel Cage Induction Generator (Scig), The Variable Speed System With Permanent Magnet Synchronous Generator (Pmsg) And The Variable Speed System With A Doubly Fed Induction Generator (Dfig) To Improve The Efficiency, Power Rating, Cost Benefit Effectiveness Etc..[1]. Among All Kinds Of Wind Energy Conversion Systems (Wecss), A Variable Speed Wind Turbine (Wt) Equipped With A Multi Pole Permanent Magnet Synchronous Generator (Pmsg) Is Found To Be Very Attractive And Suitable For Application In Large Wind Farms. The Features Is Majorly Carried Out By Suitably Assuring The Power Electronic Devices That Connect Wind Power Systems With The Grid. The Present Literature We Are Using Two Back-To-Back Ac/Dc Voltage Source Converters

With A Dc-Link Is Very Common In Today's Executions Purr Suppose The Grid Through A Back To-Back Dc-Link Is Connected To The Rotor In D Fig Wind Applications. In The Current Scenario Rotor Side Converter Is Cause For The Dominance Of The Active And Reactive Power Commuted Between The Stator And The Grid, Here Dc Voltage Regulation Is Done At A Certain Desired Level And For The Reactive Power Regulation At Unity Power Factor Operations Done By The Grid Side Converter (Gsc). The Developed Same Dc Link Is Used Squirrel Cage Induction Generators Or Permanent Magnet Synchronous Generators [1-4]. We Are Very Familiar With Wind Power Generation System With Back To Back Voltage Source Converter Control Mechanism Is Very Complex. The Entire Model In The Paper Is Grew On The Synchronously Rotating, Voltage Oriented, And Dq Reference Frame. Because At Steady-State All The Sinusoidal Quantities Are Transformed Into Dc Quantities [1]. This paper investigates ways to improve the control and operation of grid-side vsc is incurred. Also investigates how the grid current, dc-link voltage, dc-link voltage with grid sag and swell, active power, reactive power, direct-axis voltage of grid, quadrature-axis voltage of grid are how improved by using fuzzy logic controller.

II. Fuzzy Controller

We are using fuzzy logic controller and hide the PI controller. In PI controller have fixed parameters and it's very difficult to control and problems with PI controller are not solved in recent years. In the present decades of years number of applications of fuzzy logic are drastically changed. Also, fuzzy logic is appropriate for nonlinear control because it does not use complex mathematical equations. The behavior of a FLC depends on the shape of membership functions. In this paper a fuzzy logic control scheme (Fig.5) is proposed for improve the control and operation of grid-side VSC is incurred. Here we are using Mamdani's fuzzy inference method is the most commonly seen fuzzy methodology. Mamdani's method was among the first control systems built using fuzzy set theory [5].

III. 3-PHASE GRID MODEL

Assume that the grid is a symmetrical three-phase voltage source. So its voltage and Current equations can be defined as follows respectively:

$$\begin{cases} V_a = V_m \cdot \cos(\omega t) \\ V_b = V_m \cdot \cos\left(\omega t - \frac{2\pi}{3}\right) \\ V_c = V_m \cdot \cos\left(\omega t - \frac{4\pi}{3}\right) \end{cases} \quad (1)$$

$$\begin{cases} i_{ag} = I_m \cdot \cos(\omega t) \\ i_{bg} = I_m \cdot \cos\left(\omega t - \frac{2\pi}{3}\right) \\ i_{cg} = I_m \cdot \cos\left(\omega t - \frac{4\pi}{3}\right) \end{cases} \quad (2)$$

IV. Posturing of 3- VSC Expressed in ABC Reference Frame

The grid side voltage source converter is connected to the grid through an R-L filter as shown in fig(1). where as in DC side consists of capacitor in parallel to the resistance. Let us define the switching function of IGBT Sk(k=a,b,c) as the switch function of phase, k. Based on the principle in bridges any two switches cannot be on at the same time,

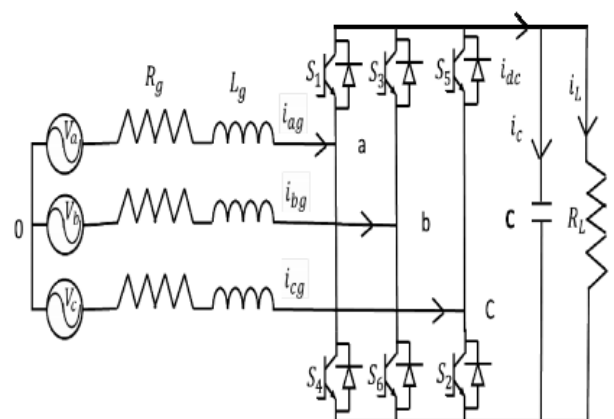

Fig.1 grid side VSC

Based on the above discussion the equations can be written as

$$S_k = \begin{cases} 1 & \text{upper IGBT on} \\ 0 & \text{upper IGBT off} \end{cases} \quad (3)$$

The instantaneous values of the current can be obtained by using Kirchoff's laws

$$\begin{cases} L_g \frac{di_{ag}}{dt} = V_a - R_g i_{ag} - V_{(a,0)} \\ L_g \frac{di_{bg}}{dt} = V_b - R_g i_{bg} - V_{(b,0)} \\ L_g \frac{di_{cg}}{dt} = V_c - R_g i_{cg} - V_{(c,0)} \end{cases} \quad (4)$$

Here the voltages are obtained with reference to power neutral point 0, then A.C side VSC voltages are $V(a,0)$, $V(b,0)$, $V(c,0)$ are obtained (5)

$$\begin{cases} V_{(a,0)} = V_{(a,N)} + V_{(N,0)} \\ V_{(b,0)} = V_{(b,N)} + V_{(N,0)} \\ V_{(c,0)} = V_{(c,N)} + V_{(N,0)} \end{cases} \quad (5)$$

For a balanced 3- ϕ system

$$V_{(a,0)} + V_{(b,0)} + V_{(c,0)} = 0 \quad (6)$$

Substituting equation (5) into (6) this will give (7) and can be deduced as

$$V_{(N,0)} = -\frac{V_{(a,N)} + V_{(b,N)} + V_{(c,N)}}{3} \quad (7)$$

Considering phase-a, when the upper IGBT is on and lower IGBT is off, $S_a = 1$ and $V(a,N) = V_{dc}$. Similarly, when the upper IGBT is off and lower IGBT is on, $S_a = 0$ and $V(a,N) = 0$. Therefore, based on the above characteristic, $V(a,N) = S_a \cdot V_{dc}$.

Similarly for phase-b and phase-c represents in (8)

$$\begin{cases} V_{(a,N)} = S_a V_{dc} \\ V_{(b,N)} = S_b V_{dc} \\ V_{(c,N)} = S_c V_{dc} \\ V_{(N,0)} = -\frac{1}{3}(S_a + S_b + S_c)V_{dc} \end{cases} \quad (8)$$

Obtaining (9) by substituting (5) and (8) into (4)

$$\begin{cases} L_g \frac{di_{ag}}{dt} = V_a - R_g i_{ag} - V_{dc} \left(S_a - \frac{1}{3} \sum_{k=a,b,c} S_k \right) \\ L_g \frac{di_{bg}}{dt} = V_b - R_g i_{bg} - V_{dc} \left(S_b - \frac{1}{3} \sum_{k=a,b,c} S_k \right) \\ L_g \frac{di_{cg}}{dt} = V_c - R_g i_{cg} - V_{dc} \left(S_c - \frac{1}{3} \sum_{k=a,b,c} S_k \right) \end{cases} \quad (9)$$

Here we are assuming for a balanced 3- ϕ system power switch resistance could be neglected.

Hence,

The relationship between AC side and DC side is given as follows:

$$\sum_{k=a,b,c} i_{kg}(t) V_{kN}(t) = i_{dc}(t) V_{dc} \quad (10)$$

By combining (8) with (10) and it gives (11)

$$i_{dc}(t) = i_{ag}(t) S_a + i_{bg}(t) S_b + i_{cg}(t) S_c \quad (11)$$

Apply Kirchoff's law

At the positive node of the DC link capacitor, as follows

$$\begin{cases} i_c = C \frac{dV_{dc}}{dt} \\ i_{dc} = i_c + i_L \\ i_{dc} = S_a i_{ag} + S_b i_{bg} + S_c i_{cg} \\ i_L = \frac{V_{dc}}{R_L} \end{cases} \quad (12)$$

Equation (12) can be modified as follows

$$C \frac{dV_{dc}}{dt} = S_a i_{ag} + S_b i_{bg} + S_c i_{cg} - \frac{V_{dc}}{R_L} \quad (13)$$

We are much known for a balanced 3- \emptyset system

$$V_a + V_b + V_c = 0 \quad (14)$$

$$i_{ag} + i_{bg} + i_{cg} = 0 \quad (15)$$

\therefore (9) Along with (13) through (15) constitute the 3- \emptyset voltage source converter model expressed in the ABC reference frame, and rewritten as follows

$$\begin{cases} C \frac{dV_{dc}}{dt} = \sum_{k=a,b,c} S_k i_{kg} - i_L \\ L_g \frac{di_{kg}}{dt} + R_g i_{kg} = V_k - V_{dc} \left(S_k - \frac{1}{3} \sum_{j=a,b,c} S_j \right), k = a, b, c \\ \sum_{k=a,b,c} V_k = \sum_{k=a,b,c} i_{kg} = 0 \end{cases} \quad (16)$$

V GRID SYNCHRONIZATION METHOD

Here we are having an idea about synchronization it means that output voltage phase angle of the three phase system has to follow their respective grid voltage phase angle and, as a consequence, the reference currents will be in phase to their corresponding voltages.

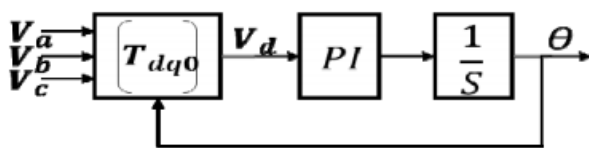

Fig.2 The configuration of three phase PLL

By using PLL principle we are developed independent synchronization. From the fig (2)

$$\text{Where } [T_{dq0}] = \frac{2}{3} \begin{bmatrix} \cos\theta & \cos\left(\theta - \frac{2\pi}{3}\right) & \cos\left(\theta - \frac{4\pi}{3}\right) \\ -\sin\theta & -\sin\left(\theta - \frac{2\pi}{3}\right) & -\sin\left(\theta - \frac{4\pi}{3}\right) \\ \frac{1}{2} & \frac{1}{2} & \frac{1}{2} \end{bmatrix} \quad (17)$$

$\theta = \omega t$, in (1)

VI POSTURING OF 3-VSC REPRESENTATION IN DQ SYNCHRONOUS REFERENCE FRAME

The above discussion gives VSC parameters represent in ABC frame. In that it has straight meaning and in that all are time variant, which will be very complex for design. Hence, we are conclude that ABC model to dq model which rotates at synchronous speed.

Hence all the parameters and components transformed to DC values. Applying the transformation matrix (17) in (16) and eliminating the zero-sequence components due to a balanced three-phase system, the VSC model expressed in the dq synchronous reference frame can be deduced and given as in

$$\begin{cases} C \frac{dV_{dc}}{dt} = \frac{3}{2} (i_{dg} S_d + i_{qg} S_q) - i_L \\ L_g \frac{di_{dg}}{dt} - \omega L_g i_{qg} + R_g i_{dg} = V_d - V_{d1} \\ L_g \frac{di_{qg}}{dt} + \omega L_g i_{dg} + R_g i_{qg} = V_q - V_{q1} \end{cases} \quad (18)$$

Where, $V_{d1} = V_{dc} S_d$ and $V_{q1} = V_{dc} S_q$.

The active and reactive power of a grid-side converter expressed in the dq synchronous reference frame are given as follows:

$$P_g = \frac{3}{2} (V_d i_{dg} + V_q i_{qg}) \quad (19)$$

$$Q_g = \frac{3}{2} (V_q i_{dg} - V_d i_{qg}) \quad (20)$$

VII GRID SIDE VSC DESIGNED BY USING FUZZY CONTROL

Fuzzy Logic Controller (FLC) is based on fuzzy logic controller and constitutes a way of converting linguistic control strategy into an automatic by generating a rule base which controls the behavior of the system. Rule based fuzzy logic controllers are useful when the system dynamics are not well known or when they contain significant non-linearities, such as the un-stationary wind contains large turbulence [6]. The fuzzy logic controller is used by replacing PI controller. Better performance can be observed using

fuzzy logic controller for power quality improvement [8]. It is a tool which deals with uncertainty and provides a technique to deal with imprecision. The fuzzy theory provides a mechanism for representing linguistic constructs such as many, low, medium and high. In fuzzy logic basic control is determined by a set of linguistic rules. The Fuzzy Logic Controller with Rule viewer block implements a fuzzy inference system (FIS) with the Rule Viewer in Simulink [7].

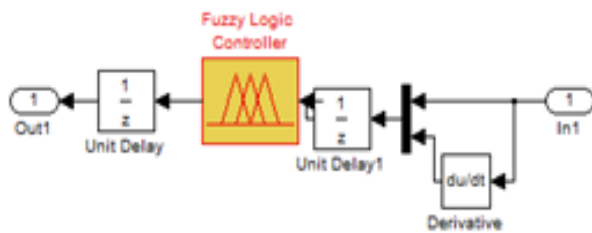

FIG(3): Structure of Control Mechanism for Grid Side Converter

Triangular-shaped membership function

Syntax = $\text{trimf}(x,[a \ b \ c])$ Compactly written as $f(x,a,b,c)=\max\left(\min\left(\frac{x-a}{b-a}, \frac{c-x}{c-b}\right), 0\right)$

The parameters a and c locate the “feet” of the triangle and the parameter b locates the peak [7].

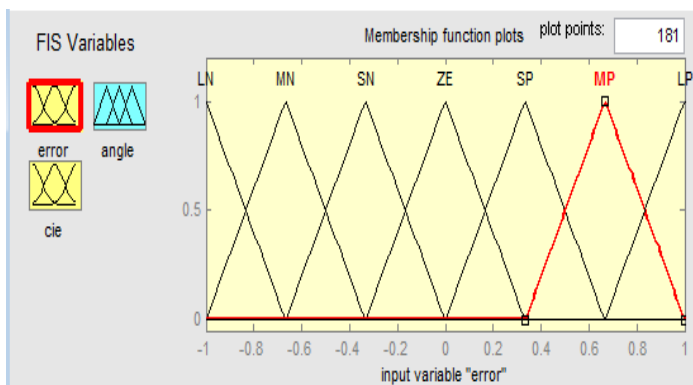

FIG (4): Input Membership Function of Fuzzy Logic Controller

VIII MATLAB/SIMULINKRESULTS

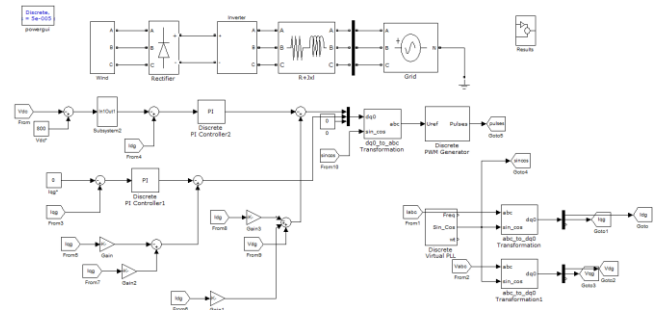

Fig (5): The block diagram of the proposed fuzzy based AC/DC GVSC Used in Wind power generation System

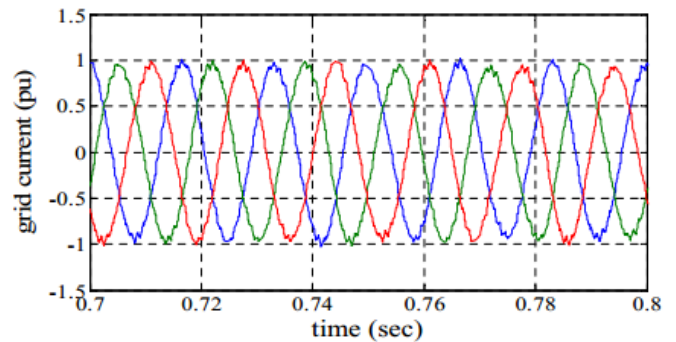

Fig (6) grid current

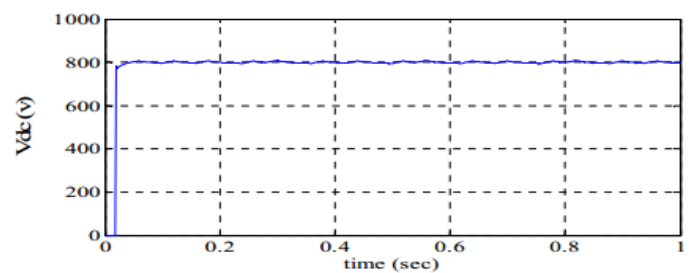

Fig (7) dc link voltage

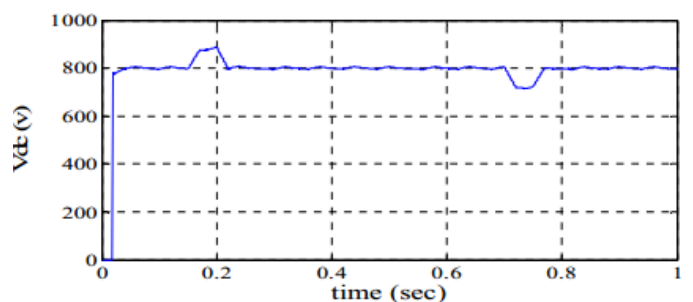

Fig (8) dc-link voltage with grid sag and swell

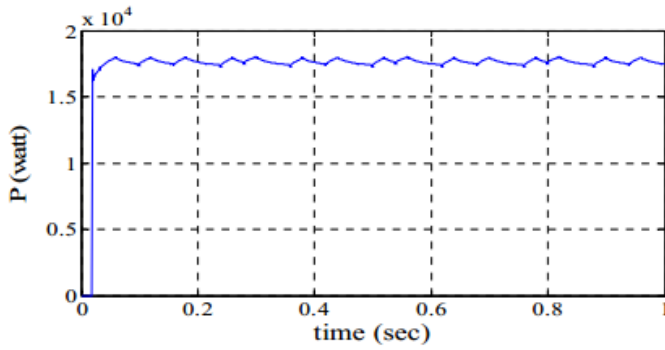

Fig (9) active power

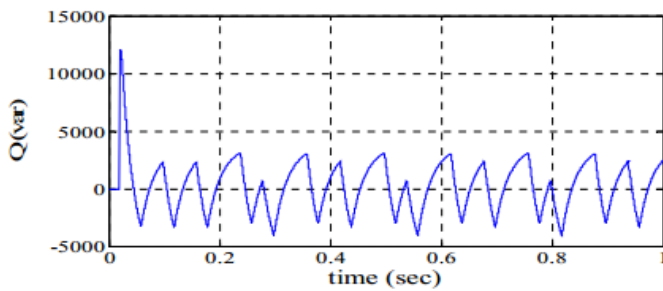

Fig (10) reactive power

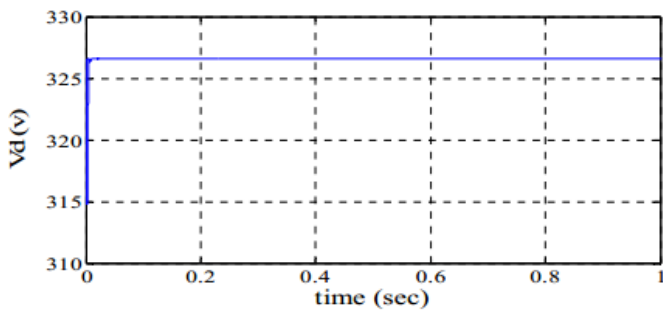

Fig (11) direct-axis voltage of grid

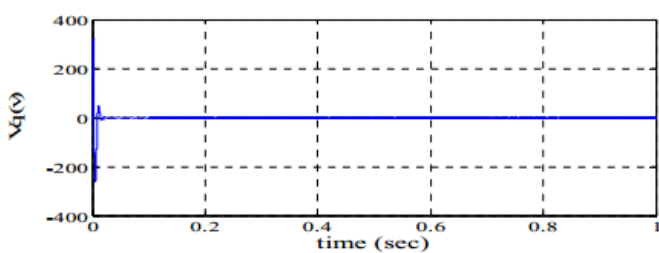

Fig (12) Quadrature-axis voltage of grid

After the fuzzy rules the following results will occurred

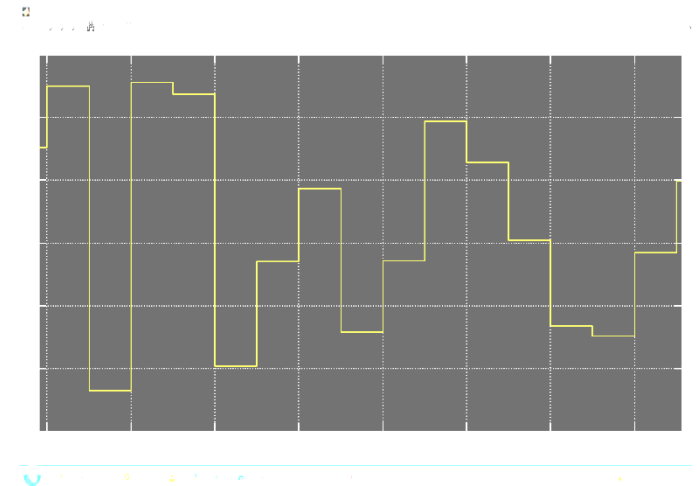

Fig (13) reactive power

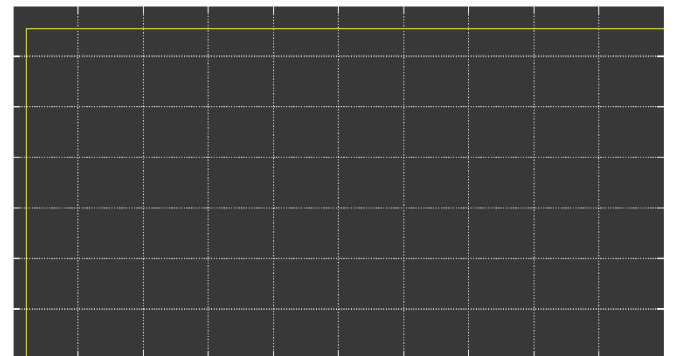

Fig (14) active power

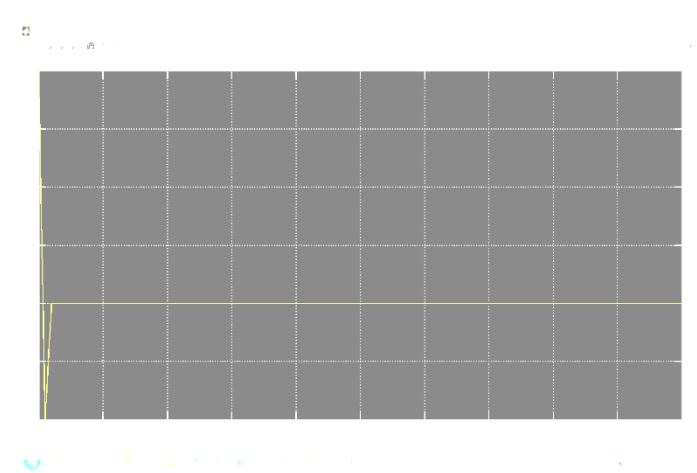

Fig (15) quadrature-axis voltage of grid

IX CONCLUSION

The detailed modeling and control of grid side VSC has been carried out for a wind power generation system. A configuration of a grid side VSC in the dc link has been proposed with a control strategy to maintain the grid power constant. The simulation results shows the proposed system is how the performance will vary of Grid current, dc-link voltage, dc-link voltage with grid sag and swell, active power, reactive power, direct-axis voltage of grid, quadrature-axis voltage of grid are how improved by using fuzzy logic controller.

REFERENCES

- [1] Y. Lei, A. Mullane, G. Lightbody, and R. Yacamini, "Modeling of the wind turbine with a doubly-fed induction generator for grid integration studies," IEEE Trans. Energy Conversion, vol. 21, no. 1, pp. 257-264, Mar. 2006.
- [2] Yifan Tang and Longya Xu, "A flexible active and reactive power control strategy for a variable speed constant frequency generating system," IEEE Trans. On Power Electronics, vol. 10, no. 4, pp. 472-478, July 1995.
- [3] I. Boldea, "Variable Speed Generators," CRC Press, Taylor and Francis Group, New-York, 2006.
- [4] A. Ostadi, A. Yazdani, and R. K. Varma, "Modeling and Stability Analysis of a DFIG-Based Wind-Power Generator Interfaced With a Series-Compensated Line," IEEE Trans. on Power Delivery, vol. 24, no. 3, pp. 1504-1514, July 2009.
- [5] T. Ackermann. Wind Power in Power Systems. Hoboken, NJ: Wiley, 2005.
- [6] P. T. Krein, J. Bentsman, R. M. Bass and B. L. Lesieutre, "On the use of Averaging for the Analysis of Power Electronic Systems", IEEE Trans. Power Electron., vol. 5, pp. 182-190, Apr. 1990.
- [7] Quazene, L., and Mcpherson,g., "Analysis of the isolated induction generator", IEEE Trans., 1983, PAS-102, pp. 2793-98.
- [8] T.-S. Lee, "Lagrangian Modeling and Passivity-Based Control of Three-Phase AC/DC Voltage-Source Converters", IEEE Trans. Ind. Electron., vol. 51, pp. 892-902, Aug. 2004.
- [9] R. Pena, J.C. Clare, and G.M. Asher, "Doubly Fed Induction Generator using back-to-back PWM converters and its application to variable-speed Wind-Energy Generation", Proc. IEE- Elect. Power Appl., vol. 143, no. 3, pp. 231-241, May 1996.
- [10] Xiaoxu Fan, Yuegang Lv, Yan Bai and Daping Xu. "Hybrid System Modeling and Analysis for Power Grid Side Converter Modulated by SVPWM Technology of the Double-fed Induction Wind Power Generator", Fourth International Conference on Natural Computation, pp. 143-148, October 2008.
- [11] Jae-Ho Choi, Hyong-Cheol Kim and Joo-Sik Kwak, "Indirect Current Control Scheme in PWM Voltage-Sourced Converter", Proceedings of the Power Conversion Conference, pp. 277-282, Nagaoka, August 1997.
- [12] Vladimir Blasko and Vikram Kaura, "A New Mathematical Model and Control of a Three-Phase AC-DC Voltage Source Converter", IEEE Transactions on Power Electronics, Vol. 12, No. 1, pp. 116-123, January 1997.
- [13] Bong-Hwan Kwon, Jang-Hyoun Youm and Jee-Woo Lim, "A Line-Voltage-Sensorless Synchronous Rectifier" IEEE Trans. on Power Electronics, Vol. 14, No. 5, pp. 966-972, September 1999.
- [14] Yan Guo, Xiao Wang, Howard C. Lee and Boon-Teck Ooi, "Pole-Placement Control of Voltage-Regulated PWM Rectifiers Through Real-Time Multiprocessing", IEEE Transactions on Industrial Engineering, Vol. 41, No. 2, pp. 224-230, April 1994.
- [15] Juan W. Dixon and Boon-Teck Ooi, "Indirect Current Control of a Unity Power Factor sinusoidal Current Boost Type Three-phase Rectifier", IEEE Transactions on Industrial Electronics, Vol. 35, No. 4, pp. 508-515, November 1988.