

A Predictive Current Control Based Shunt Active Power Filter



Gurram Mounika
M.Tech Student
Department of EPS
Anasuyadevi Engineering College.



P. Vidyasagar
Associate Professor
Department of EEE
Anasuyadevi Engineering College.

Abstract:

The non-linear loads are connected at the point of common coupling generates the harmonics, which may deteriorate the power quality. The active power filter has been proved to be an effective method to mitigate harmonic currents generated by the non-linear loads as well as to compensate reactive power. The methods of harmonic current compensation play a crucial part in the performance of active power filter. Traditionally, active power filters have been controlled using pre-tuned controllers, such as PI-type or adaptive, for the control of current as well as the dc-voltage loops. PI controllers must be designed based on the equivalent linear model.

Predictive controllers use the nonlinear model, which is closer to real operating conditions in order to improve the performance and life of the power switches of voltage source inverter (VSI), reduces its switching frequency. An active power filter implemented with a 4-leg voltage source inverter using a predictive control scheme is presented in this paper. Predictive current control algorithm is based on the system model. The compensation performance of the proposed active power filter and the associated control scheme under steady state and transient operating conditions is demonstrated through simulations using MATLAB/SIMULINK.

Keywords: SAPF, 4-Leg VSI, PI, Predictive Current Control, SRF-PLL, PWM.

I. INTRODUCTION

The electrical energy consumption behavior is random and unpredictable, therefore it may be single- or three-phase, balanced or unbalanced and linear or nonlinear [1]. Nonlinear load contains harmonics to reduce the harmonics uses the filters. Filters are two types passive, active. Passive power filters can filter frequency only the frequencies they were previously tuned for their operation can be limited to a certain load. Resonance problem will be accruing because of the interaction between the passive filters and other loads with unpredictable results [2]. To come out of these disadvantages recent efforts are concentrated in the development of active power filters. An active power filter is connected in parallel at the point of common coupling to compensate current harmonics, current unbalance, and reactive power generated by the non-linear loads [3]. The principle of the shunt active power filter (SAPF) is to produce harmonic currents equal in magnitude but opposite in-phase to those harmonics that are present in the grid. SAPF can compensate reactive power and can also mitigate harmonics and distortions. $I(\text{comp}) = I(\text{load}) - I(\text{source})$. Conventional active power filter implemented with a three-phase three leg topology. In three leg topology the zero sequence currents in the load cannot be compensated and hence the zero sequence currents flow in the neutral wire (Between the system and load). The zero sequence currents thus return to the ac distribution system. If the load is non-linear and contain harmonics then these harmonics also enter ac system thus degrading the power quality. In

three leg inverter, if the load requires a neutral point connection a simple approach is to use the dc link capacitor split in two and ties the neutral point to the midpoint of two capacitors. In this case the unbalanced loads will cause the neutral currents that flow through the fourth wire distorting the output voltage. Another drawback is the need for excessively large dc link capacitors [3]. To overcome these drawbacks go for 4-Leg VSI. In this paper 4-Leg VSI using predictive control scheme for effective harmonic compensation.

II. PROPOSED SYSTEM

The four-leg PWM converter topology is shown in Figure 1 the converter topology is similar to the conventional three-phase converter with the fourth leg connected to the neutral wire of the system. The four-leg increases states of switches from 8(23) to 16 (24), improving control flexibility and output voltage quality and is suitable for current unbalanced compensation

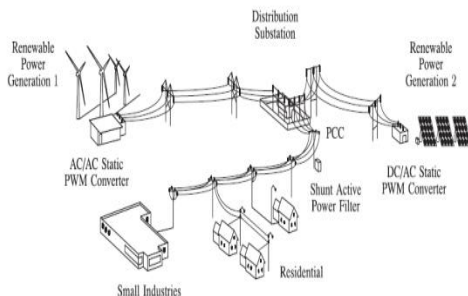

Fig. 1. Stand-alone hybrid power generation system with a shunt active power filter.

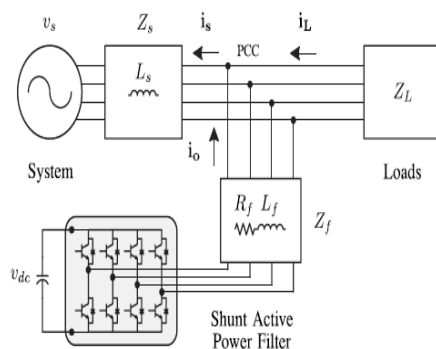

Fig. 2. Three-phase equivalent circuit of the proposed shunt active power filter.

FOUR-LEG CONVERTER MODEL

The voltage in any leg x of the converter, measured from the neutral point (n), can be expressed in terms of switching states as follows

$$v_{un} = S_u - S_n v_{dc} \quad (1)$$

The mathematical model of the filter derived from the equivalent circuit shown in Figure 1

$$v_o = v_{un} - R_{eq} i_o - L_{eq} \frac{di_o}{dt} \quad (2)$$

Where in Eq. (2) Req and Leq are the 4-Leg VSI output parameters used in thevenin impedance (Zeq) at the converter output terminals. Therefore the equivalent impedance is determined by a series connection of the ripple filter impedance Z and a parallel arrangement between the system equivalent impedance Zs and the load impedance ZL as shown in Figure 2.

$$Z_{eq} = \frac{Z_s Z_L}{Z_s + Z_L} + Z_f \approx Z_s + Z_f \quad (3)$$

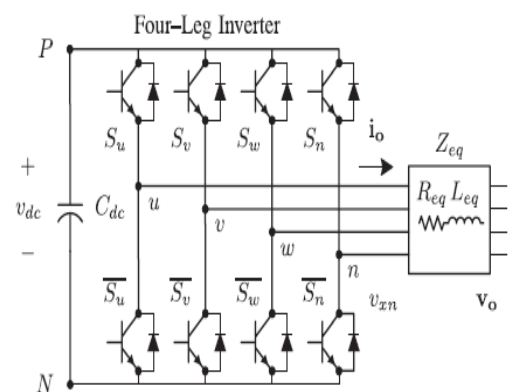

Fig. 3. Two-level four-leg PWM-VSI topology.

For this model, it is assumed that $Z_s \gg Z_L$ that the resistive part of the system's equivalent impedance is neglected, and that the series reactance is in the range of 3–7% p.u., which is an acceptable approximation of the real system. Finally in Eq. (3) $R_{eq} = R_f$ and $L_{eq} = L_f + L_s$.

III. PROPOSED CONTROL SYSTEM

Proposed Predictive Control Method

The proposed predictive control strategy is based on the fact that only a finite number of possible states of switches can be generated by a static power converter and that models of the system can be used to predict the behavior of the variables for each state of switching. Then selected the appropriate state of switching can be applied to next interval state. This selection criteria is expressed as a quality function that will be evaluated for the predicted values of the variables to be controlled. The main characteristic of predictive control is the use of the system model to predict the future behavior of the variables to be controlled. This information is given to the controller to select the optimum switching state that will be applied to the power converter according to obtained optimization criteria. The predictive control algorithm is easy to implement and to understand.

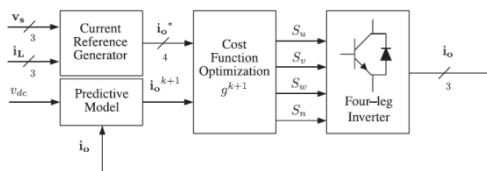

Figure 3: Predictive current control block diagram
Current Reference Generator:

This unit is designed to generate the required current reference that is used to compensate the undesirable load currents. Here, the dc converter voltage, load currents and the system voltages are measured, while the source neutral current and neutral load current are generated directly from these signals.

3.1 Prediction Model The converter model is used to predict the output converter current. Here the controller operates in discrete time, such that the controller and the system model must be represented in a discrete time domain. The model consists of recursive matrix equations that represent this prediction system. This means that for a given sampling time T_s , that the converter switching states and control variables at instant kT_s , such that it is

possible to predict the next states at any instant $[k + 1]T_s$. The algorithm calculates all 16 values associated with the possible combinations that the state variables can achieve. The prediction model is used to predict the output converter current.

dq-Base Current Reference Generator Modeling A dq-based current reference generator scheme is used to obtain the active power filter current reference signals. The dq-base scheme has fast accurate, response and signal tracking capability.

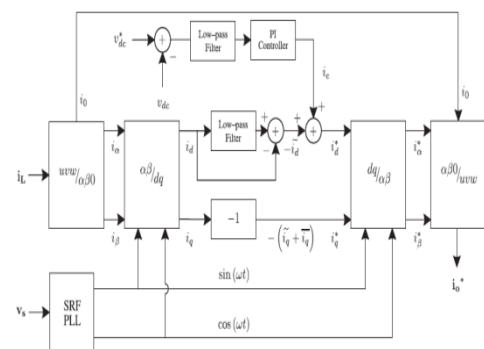
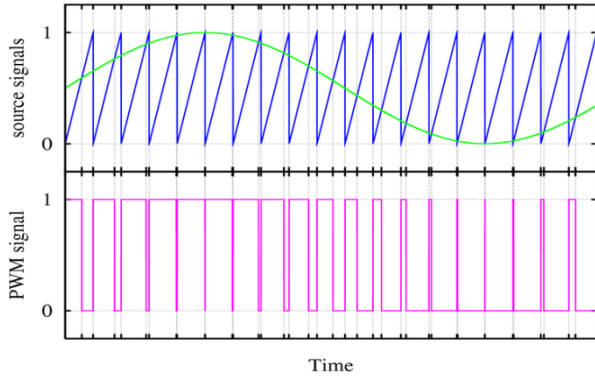

Figure 4: dq-based current reference generator block diagram .

dq- based current reference generator scheme characteristic avoids voltage fluctuations that deteriorate the current reference signal performance of compensation. The reference current signals are obtained from the corresponding load currents as shown in Figure 4. The dq-based scheme operates in rotating reference theory. The currents measured must be multiplied by the $\sin(\omega t)$ and $\cos(\omega t)$ signals. By using dq-transformation, the d-axis current component is synchronized with the corresponding phase-to-neutral system voltage, and the q-axis current component is phase-shifted by 90° . The $\sin(\omega t)$ and $\cos(\omega t)$ synchronized reference signals are obtained from a synchronous reference frame (SRF). The SRF-PLL generates a pure sinusoidal waveform even when the system voltage is severely distorted. Tracking errors are eliminated.

In this PWM block added after hysteresis current control to generate pulses

PWM Generation – Analog



- When sine is greater than sawtooth PWM is high.
- When sine is less than sawtooth PWM is low.
- PWM toggles when sine equals sawtooth

PWM Generation – Digital

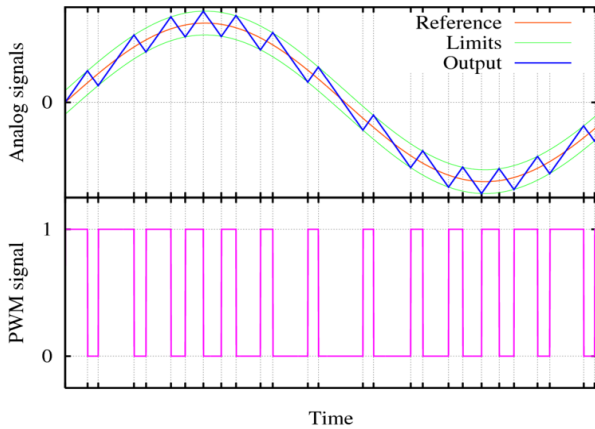

- Output is integrated. Limit signals which are offset from a reference. When output signal reaches limit, PWM state changed.

IV. SIMULATION RESULTS

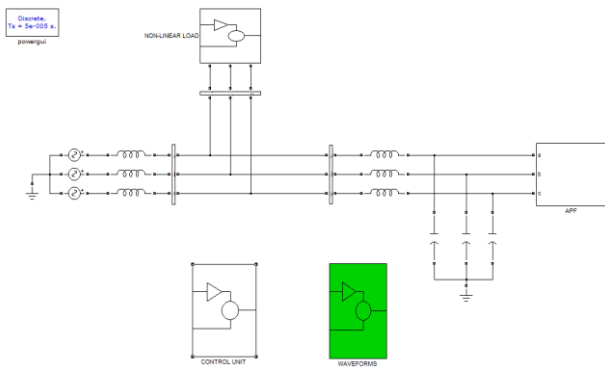

Fig.5 Simulation Circuit

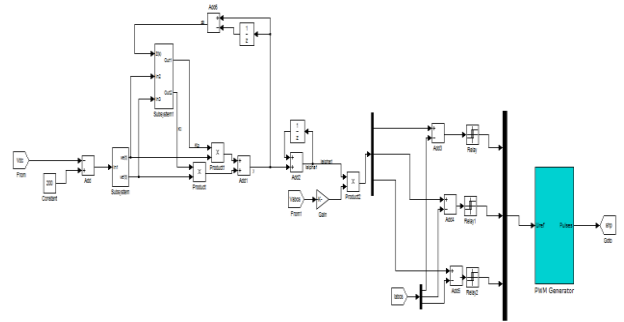

Fig.6 CONTROL UNIT

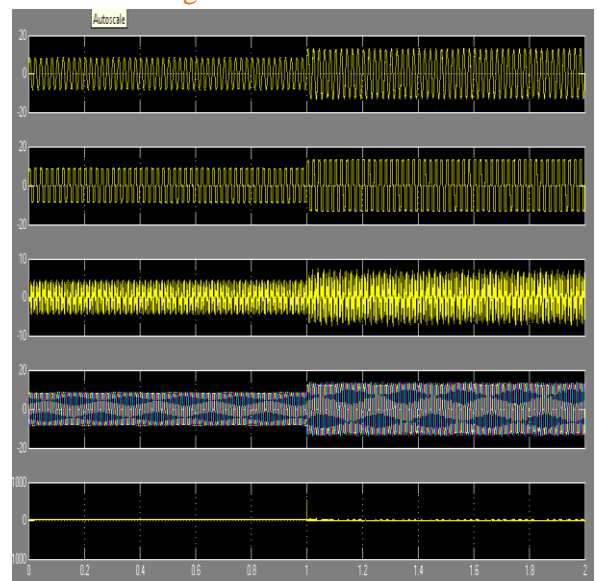

Fig.7 ISa,ILa,inv,ISabc,Vdc

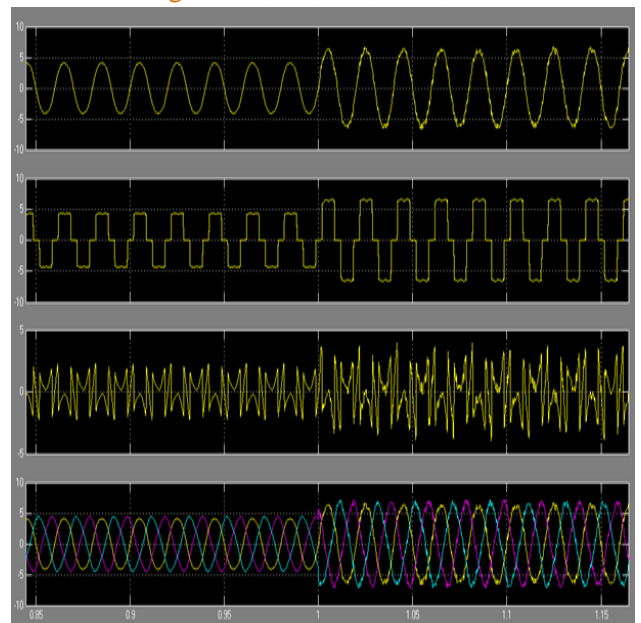

Fig.8 ISa,ILa,inv,ISabc(zoomed waveforms)

V.CONCLUSION

The proposed SAPF control scheme advantages are related to its simplicity, implementation and modeling. The use of a predictive control algorithm for the converter current loop proved to be an effective solution for improving current quality of the distribution system. The system tracking capability and transient response is improved. The predictive current controller is a stable and robust solution. The proposed algorithm mitigates the system harmonic currents and reactive power compensation simulated results have been shows the compensation effectiveness of the proposed active power filter References

References

- [1] J. Rocabert, A. Luna, F. Blaabjerg, and P. Rodriguez, "Control of power converters in AC microgrids," *IEEE Trans. Power Electron.*, vol. 27, no. 11, pp. 4734–4749, Nov. 2012.
- [2] Abhijit A Dutta, Manisha Sabley, B.S.Sudame and A.N.Kadu, "Harmonic Compensation in Power System using Active Power Filters" *Int. Journal of Multidisciplinary and Current research*, vol. 2, pp. 188-192, , Nov/Dec 2013 .
- [3] Shweta R Malluramath , V.M.Chougala, "Improving the Power Quality by Four Leg VSI" *International Journal of Engineering Trends and Technology (IJETT)* , Vol.4, pp. 8031-8034, May5, 2013.
- [4] N. Prabhakar and M. Mishra, "Dynamic hysteresis current control to minimize switching for three-phase four-leg VSI topology to compensate nonlinear load," *IEEE Trans. Power Electron.*, vol. 25, no. 8, pp. 1935–1942, Aug. 2010.
- [5] V. Khadkikar, A. Chandra, and B. Singh, "Digital signal processor implementation and performance evaluation of split capacitor, four-leg and three h-bridge-based three-phase four-wire shunt active filters," *Power Electron., IET*, vol. 4, no. 4, pp. 463–470, Apr. 2011.
- [6] F. Wang, J. Duarte, and M. Hendrix, "Grid-interfacing converter systems with enhanced voltage quality for microgrid application; concept and implementation," *IEEE Trans. Power Electron.*, vol. 26, no. 12, pp. 3501–3513, Dec. 2011.
- [7] X.Wei, "Study on digital pi control of current loop in active power filter," in *Proc. 2010 Int. Conf. Electr. Control Eng.*, Jun. 2010, pp. 4287–4290.
- [8] R. de Araujo Ribeiro, C. de Azevedo, and R. de Sousa, "A robust adaptive control strategy of active power filters for power-factor correction, harmonic compensation, and balancing of nonlinear loads," *IEEE Trans. Power Electron.*, vol. 27, no. 2, pp. 718–730, Feb. 2012.
- [9] J. Rodriguez, J. Pontt, C. Silva, P. Correa, P. Lezana, P. Cortes, and U. Ammann, "Predictive current control of a voltage source inverter," *IEEE Trans. Ind. Electron.*, vol. 54, no. 1, pp. 495–503, Feb. 2007.
- [10] P. Cortes, G. Ortiz, J. Yuz, J. Rodriguez, S. Vazquez, and L. Franquelo, "Model predictive control of an inverter with output LC filter for UPS applications," *IEEE Trans. Ind. Electron.*, vol. 56, no. 6, pp. 1875–1883, Jun. 2009.

AUTHOR DETAILS:

Gurram Mounika, Received B.tech from Vijaya Engineering college ,Khammam ,Telangana in 2012 ,currently pursuing M.tech in Electrical power systems at Anasuyadevi Institute of Technology & Science ,Gudur, Bibinagar (M),Nalgonda (Dst), Telangana. Area of interest in Electrical inspection field .Had an experience of 2 years as a Quality control executive.

P.Vidyasagar, Obtained his B.tech (EEE) degree from vidyabharathi institute of technology ,jangaon ,



ISSN No: 2348-4845

International Journal & Magazine of Engineering, Technology, Management and Research

A Peer Reviewed Open Access International Journal

Warangal (Dst), Telangana . M.tch (Power Electronics) from Aurora's engineering college ,Bhongir in 2014 .He worked as Assistant Professor in VidyaBharati Institute of Technology jangaon and Asst professor at Sri Indu college of engineering &technology ,Ibrahimpattanam . He has been working as Associate Professor in dept of EEE at anasuyadevi Institute of technology & science since 2014 . He is having 5 years' teaching experience.