

## Power Quality Improvement in Low-Voltage Distribution Grids Using Voltage Regulator

**Billa Sowjanya**

Department of Electrical & Electronics Engineering,  
Malineni Lakshmaiah Engineering College,  
Singaraya Konda, Prakasham, A.P 523101, India.

**Y.Ramaiah**

Department of Electrical & Electronics Engineering,  
Malineni Lakshmaiah Engineering College,  
Singaraya Konda, Prakasham, A.P 523101, India.

### ABSTRACT:

*This paper here a voltage-controlled DSTATCOM-based voltage regulator for low voltage allocation grids. The voltage regulator is intended to momentarily meet the grid code, postponing unplanned investments while an ultimate explanation could be planned to resolve regulation concerns. The power stage is poised of a three-phase four-wire Voltage Source Inverter (VSI) and a second order low-pass filter. The control approach has three output voltage loops with active damping and two dc bus voltage loops. In accumulation, two loops are incorporated to the projected control approach: the idea of Minimum Power Point Tracking (mPPT) and the frequency loop. The mPPT allows the voltage regulator to operate at the Minimum Power Point (mPP), avoiding the circulation of unnecessary reactive compensation. The frequency loop allows the voltage regulator to be independent of the grid voltage information, especially the grid angle, using only the information available at the Point of Common Coupling (PCC).*

*Experimental results show the regulation capacity, the features of the mPPT algorithm for linear and nonlinear loads and the frequency stability.*

### I. Introduction:

The end of low voltage distribution grids may occurrence poor voltage regulation. According to Brazilian grid code [, power companies have constrained deadlines (15 to 90 days) to restore the voltage levels at the Point of Common Coupling (PCC) if the voltages are outside the admissible levels. The time needed for permanent solutions, like grid restructuring or capacitor banks installation, to be operational may exceed the

deadlines. In the case of failure to meet the deadlines, the power company has to refund every customer in the distribution grid during the time that the poor voltage regulation persisted.

Aiming to prevent refunds, a voltage regulator can be utilized as a temporary solution. The voltage regulator must have fast voltage regulation, reduced weight and easy installation. Using the proposed solution, the grid Power quality is re-established and the PCC voltage is restored in a short period of time. In the meantime, the permanent solution can be planned and installed in an appropriate time frame. Once the definite solution is implemented, the voltage regulator can be disconnected from the grid and connected to another grid with similar problems.

In real applications, poor voltage regulation occurs when the PCC is far from the main grid transformer and the distance between the PCC and the transformer can easily be further than 100 meters. Access to grid voltage information can be difficult to obtain. To meet the voltage regulation requirement, a voltage-controlled DSTATCOM-based voltage regulator is proposed with shunt connection to PCC [2]–[9], as shown in Fig. 1. The shunt connection avoids power supply interruption while the voltage regulator is installed or disconnected. The proposed DSTATCOM allows the power company to postpone investments and enhances the flexibility of grid management.

**Cite this article as:** Billa Sowjanya & Y.Ramaiah, "Power Quality Improvement in Low-Voltage Distribution Grids Using Voltage Regulator", International Journal & Magazine of Engineering, Technology, Management and Research, Volume 5 Issue 12, 2018, Page 1-6.

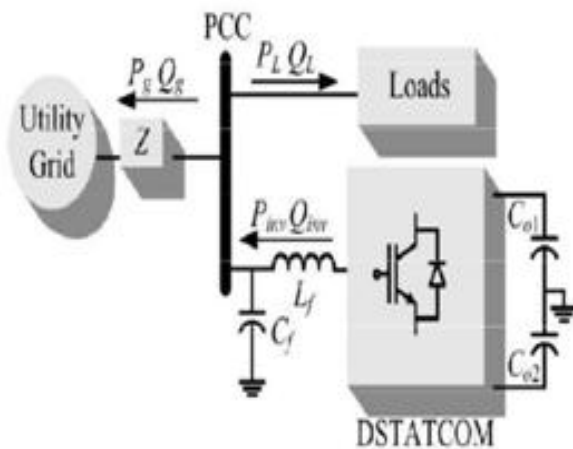

**Fig. 1. Low voltage distribution grid under analysis with the voltage regulator**

Voltage-controlled DSTATCOM can preserve the PCC voltages balanced even under grid or load unbalances. The PCC voltage is directly controlled by the DSTATCOM and abrupt load variations have no important impact in the PCC voltage waveforms. In addition, the voltage-controlled DSTATCOM decouples the grid and the loads, serving as a low impedance path for harmonic distortions due the voltage source actions. Current harmonic distortions from the loads have small impact in the grid and vice versa. The grid current quality, therefore, is exclusively given by the grid voltage quality.

According to [3], angular position reference is required for the voltage-controlled DSTATCOM to work properly. Before the DSTATCOM starts its operation, synchronization circuits generate the angular position to the voltage regulator. Once the operation begins, the voltage-controlled voltage regulator replaces the PCC voltage and the grid voltage frequency and angle are no longer available. PCC voltage frequency and angle are then determined by the voltage regulator. For a real application, due to the distance between the transformer and the PCC, only the PCC voltage should be measured to compose the voltage reference of the DSTATCOM.

In past years, the PCC voltage amplitude (VPCC) for responsive remuneration strategies was normally

received as the ostensible network voltage, i.e. 1.00 p.u. In any case, Brazilian lattice code decides a most extreme (1.05 p.u.) and a base (0.92 p.u.) voltage amplitude for low voltage appropriation matrices. The PCC amplitude can be seen as a level of opportunity and the prepared power can be decreased with a reasonable control circle. In this exertion, [8] proposes another technique to decide the reasonable PCC terminal voltage for decrease of the DSTATCOM control rating. The strategy is figured by the coveted source current, intending to accomplish the solidarity control factor at the lattice. In any case, this strategy requires data about the source current, network opposition and reactance. In [9] the creators propose another strategy to decide appropriate VPCC utilizing the positive grouping segments of the heap current to figure the PCC voltage.

In the two cases, extra data is required, expanding the procedure multifaceted nature, number of sensors and the cost of the arrangement. To keep up the simple establishment highlight and sensible costs, it is advantageous to set the PCC voltage, in which the prepared power is insignificant, without checking any heap or lattice data and utilizing just inside signs of the DSTATCOM, for example, the PCC voltages and DSTATCOM yield streams.

This paper introduces a voltage-controlled DSTATCOM-based voltage controller for low voltage appropriation lattices, utilizing a three-stage four-wire VSI with a LC low-pass yield channel, as appeared in Operation standards of the voltage-controlled DSTATCOM and the control procedure are displayed.

Also, two circles are incorporated to the proposed control technique: the idea of least power point following (mPPT) and the recurrence circle [11]. The mPPT maintains a strategic distance from superfluous receptive remuneration, expanding the pay capacity. The recurrence circle beats the functional trouble of synchronization by redressing the recurrence of the voltage reference.

## **II. BASIC CONCEPTS OF DSTATCOM**

A distribution static compensator is a voltage source converter based power electronic device. Usually, this device is supported by short term energy stored in a dc capacitor. The DSTATCOM filters load current such that it meets the specifications for utility connection. The DSTATCOM can fulfill the following points.

- The result of poor load power factor such that the current drawn from the supply has a near unity power factor.
- The result of harmonic contents in loads such that current drawn from the supply is sinusoidal.
- The result of unbalanced loads such that the current drawn from the supply is balanced.
- The dc offset in loads such that the current drawn from the supply has no offset.

One of the main features of DSTATCOM is the generation of the reference compensator currents. The compensator, when it tracks these reference currents, injects three-phase currents in the ac system to cancel out disturbances caused by the load. Therefore, the generation of reference currents from the measurements of local variables has fascinated wide attention [5]. These methods carry an inherent assumption that the source is stiff (i.e., the voltage at the point of common coupling is tightly regulated and cannot be influenced by the currents injected by the shunt device). This however is not a valid assumption and the concert of the compensator will reduce considerably with high impedance ac supplies.

The operation of VSI is supported by a dc storage capacitor with appropriate dc the transient response of the voltage across it. The transient response of the DSTATCOM is very significant while compensating AC and DC loads [15].

A static synchronous compensator (STATCOM) is one of the most operative solutions to regulate the line voltage. The STATCOM consists of a voltage source converter connected in shunt with the power system and permits to control a leading or lagging reactive power by means of correcting its ac voltage. A STATCOM for

installation on a distribution power system called DSTATCOM, has been researched to clear voltage fluctuations and voltage flickers. A shunt active filter intended for installation on a power distribution system, with emphasis on voltage regulation capability. Theoretical investigation as well as computer simulation provides the dynamic performance of harmonic damping and voltage regulation. As a result, harmonic damping has the capability to improve the stability of voltage regulation.

Thus, modification of the feedback gains makes it possible to decrease voltage fluctuation in transient states, when the active filter has the function of combined harmonic damping and voltage regulation. The simulation results are shown to verify the effectiveness of the active filter capable of both harmonic damping and voltage regulation.

The grid frequency has small frequencies deviations around the nominal value and many loads can operate under such deviations. However, voltage-controlled DSTATCOM synthesizes the PCC voltage with a constant frequency. Large differences between the grid and PCC frequencies, associated with long frequency deviations, may lead to disconnection of the DSTATCOM.

A distribution static compensator (DSTATCOM) is implemented for controlling a distributed power generating system using a proposed composite observer based control technique. The proposed control technique is employed for the fundamental components extraction of distorted load currents. These extracted components are used in the estimation of reference source currents to generate gating signals of DSTATCOM. The proposed control technique is implemented for the mitigation of reactive power, distortion in term of harmonics, and load balancing under linear/nonlinear loads. The performance of DSTATCOM is observed satisfactory for these consumer loads with regulated generator voltage at point of common coupling and self-supported dc link of voltage-source converter of DSTATCOM.



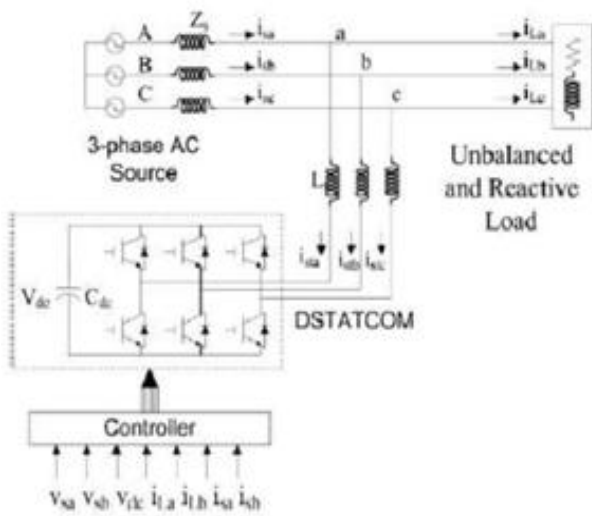

**Fig.2. Basic Circuit Diagram of the DSTATCOM System.**

### III. Proposed Control Strategy Minimum Power Point Tracker

The voltage amplitude to be regulated at PCC changes the power flow between the grid, load and DSTATCOM, as demonstrated in Section II. Suitable VPCC makes the processed apparent power be minimal.

When the VPCC is between the desired voltage limits, the mPPT minimizes the converter apparent power and no reactive power at the grid frequency is processed. Apparent power minimization means current minimization, which lower the losses and extends the equipment life cycle. For the mPPT analysis, apparent power is chosen to be minimized instead of reactive power due to: (i) active power in DSTATCOMs is a small fraction of the apparent power; (ii) the harmonic currents from the grid and load are also processed; (iii) the converter power rating and the losses are given by the apparent power; and (iv) apparent power is easier to calculate in comparison to extracting the reactive power at the grid frequency from distorted current waveforms.

The reduction of voltage regulator apparent power can be performed by tracking algorithms. An example of tracking algorithm is the Maximum Power Point Tracker (MPPT), which is widely used in PV systems.

Among several MPPT algorithms, the Perturb & Observe (P&O) method was chosen to compose the mPPT algorithm due to its simplicity, low computational effort and a small number of sensors, although it has slow transient response and operates around a Maximum Power Point (MPpt), which can be a local or a global MPP.

Two parameters must be set to the P&O algorithm: perturbation amplitude and sample time. The perturbation amplitude defines the convergence time to reach the MPP and the amplitude of the oscillations in steady state. The sample period must be greater than the response time of the system to avoid instabilities. One interesting feature of the P&O method is its independency of PV arrays parameters. This feature makes the P&O not restricted to PV systems. The P&O-based mPPT algorithm presents the same features of the P&O algorithm applied to MPPT, but is designed to achieve the Minimum Power Point (mPP) instead of MPP.

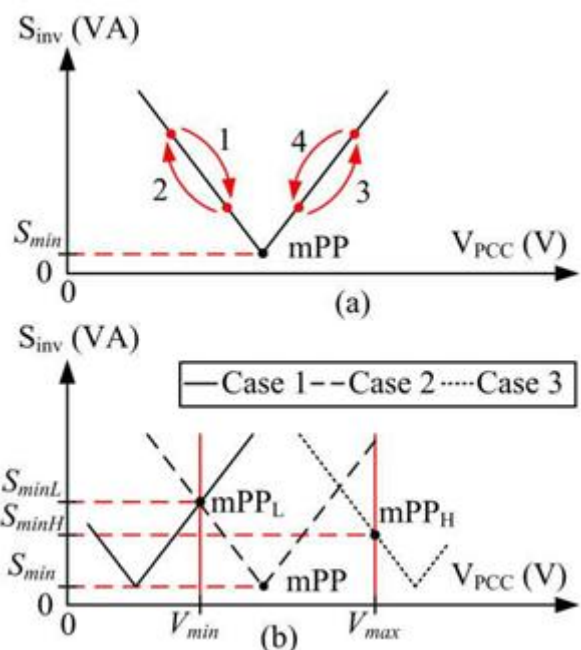

**Fig. 3. (a) P&O-based mPPT derivation (b) Example of the mPPT algorithm with voltage constraints**

The mPPT can be derived examine. The indication 1 characterize an amplify of VPCC and the indication 4

characterize a diminish of VPCC which escort to decrease of the  $S_{inv}$ . In these cases, the next perturbation will preserve the perturbation signal (positive for marker 1 and negative for marker and the mPPT will converge to the mPP. On the other hand, the marker 2 represents a decrease of VPCC and the marker 3 represents an increase of VPCC diverging from mPP. Therefore, the direction of the next perturbation must be positive for marker 2 and negative for marker 3.

The mPPT algorithm is summarized in. Comparing the perturbation logic of the P&O mPPT with the conventional P&O MPPT algorithm, one can conclude that the P&O-based mPPT can be obtained by simply changing the perturbation signal of the conventional P&O MPPT. The processed power at the mPP was intentionally considered as  $S_{min}$ , the minimal power to be processed. DSTATCOM losses and harmonic distortions contributions to the apparent power cannot be minimized to zero.

The amplitude loop is composed of the P&O-based mPPT algorithm and has voltage constraints to meet, which are imposed by the Brazilian grid code. The voltage constraints are not considered in and directly affect the apparent processed power. There are three different cases when voltage constraints are present as depicted in Fig. 3 (b). In case 1,  $S_{min}$  requires a VPCC below the minimum allowable PCC voltage ( $V_{min}$ ). The mPPT goes toward the mPP, but VPCC cannot be lower than  $V_{min}$ . VPCC is kept at  $V_{min}$  and the voltage regulator supplies reactive power to maintain the VPCC regulated. Therefore, the mPP in case 1 will be at mPPL and the processed power is represented by  $S_{minL}$ . The Case 3 shows a similar outcome to case 1 with VPCC kept at the maximum allowable PCC voltage ( $V_{max}$ ). The converter operates at mPPH and process reactive power equal to  $S_{minH}$ .

In case 2, the mPP occurs with VPCC between  $V_{max}$  and  $V_{min}$ . The mPPT tracks the mPP and the converter process  $S_{min}$ , the active power to compensate the losses and the harmonic distortion from the grid and load.

**IV Simulation Results:  
Proposed circuit**

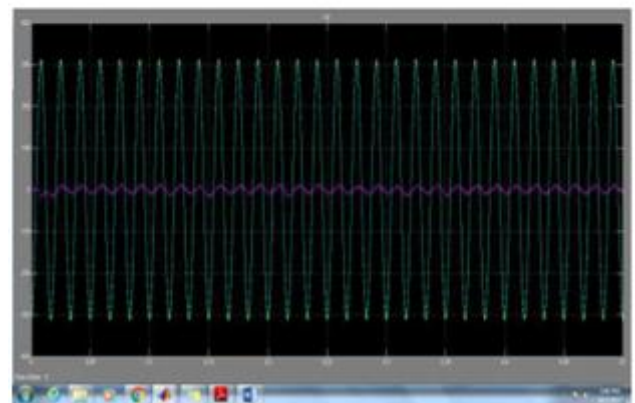
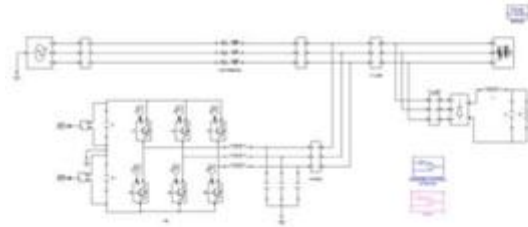
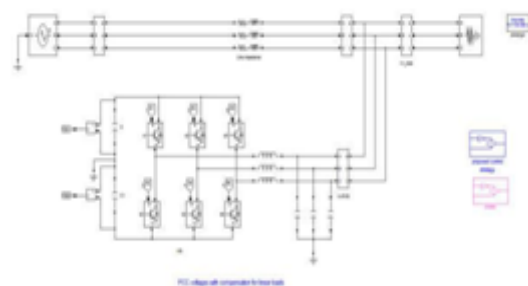
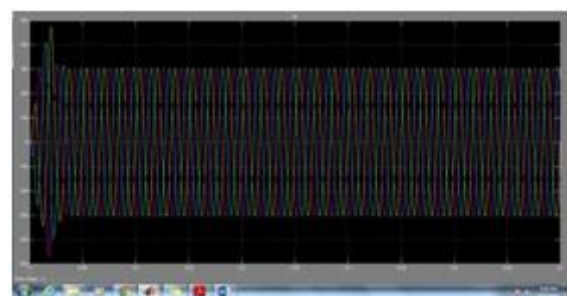

Fig. Total dc bus voltage, PCC voltage, grid voltage and voltage regulator current waveforms of a-phase with mPPT enabled with grid swell



Proposed circuit with compensation for linear loads



**LINEAR\_DSTATCOM\_WITHCOM**  
PCC voltages with compensation for linear loads

## V. Conclusion:

This paper presents a three phase DSTATCOM as a voltage regulator and its control strategy, composed of the conventional loops, output voltage and dc bus regulation loops, including the voltage amplitude and the frequency loops.

Simulation results express the voltage regulation ability, supplying three balanced voltages at the PCC, even under nonlinear loads. The projected amplitude loop was able to diminish the voltage regulator process apparent power about 51 % with nonlinear load and even more with linear load (80%). The mPPT algorithm tracked the minimum power point within the allowable voltage range when reactive power compensation is not necessary. With grid voltage sag and swell, the amplitude loop meets the grid code. The mPPT can also be implemented in current-controlled DSTATCOMs, achieving similar results.

The frequency loop kept the compensation angle within the analog limits, increasing the autonomy of the voltage regulator, and the dc bus voltage regulated at nominal value, thus minimizing the dc bus voltage steady state error. Simultaneous operation of the mPPT and the frequency loop was verified. The proposed voltage regulator is a shunt connected solution, which is tied to low voltage distribution grids without any power interruption to the loads, without any grid voltage and impedance information, and provides balanced and low-THD voltages to the customers.

## REFERENCES

- [1] ANEEL National Electric Power Distribution System Procedures – PRODIST, Module 8: Energy Quality. Revision 07, 2014.
- [2] M. Mishra, A. Ghosh and A. Joshi, "Operation of a DSTATCOM in voltage control mode," IEEE Trans. Power Del., vol. 18, no. 1, pp. 258-264, Jan. 2003.
- [3] G. Ledwich and A. Ghosh, "A flexible DSTATCOM operating in voltage or current control mode," IEE Proc.-

Gener., Transmiss. Distrib., vol. 149, n. 2, pp. 215-224, Mar. 2002.

[4] T. P. Enderle, G. da Silva, C. Fischer, R. C. Beltrame, L. Schuch, V. F. Montagner and C. Rech, "D-STATCOM applied to single-phase distribution networks: Modeling and control," in Proc. IEEE Ind. Electron. Soc. Annu. Conf., Oct. 2012, pp. 321 - 326.

[5] C. Kumar and M. Mishra, "Energy conservation and power quality improvement with voltage controlled DSTATCOM," in Proc. Annu. IEEE India Conf., Dec. 2013 pp. 1-6.

[6] R. T. Hock, Y. R. De Novaes and A. L. Batschauer, "A voltage regulator based in a voltage-controlled DSTATCOM with minimum power point tracker," in Proc. IEEE Energy Convers. Congr. Expo., Sep. 2014, pp. 3694-3701.

[7] B. Singh, R. Saha, A. Chandra and K. Al-Haddad, "Static synchronous compensators (STATCOM): a review," IET Power Electron., vol. 2, no. 4, pp. 297-324, Jul. 2009.

[8] C. Kumar and M. Mishra, "A Multifunctional DSTATCOM Operating Under Stiff Source," IEEE Trans. Ind. Electron., vol. 61, no. 7, pp. 3131-3136, Jul. 2014.

[9] C. Kumar and M. Mishra, "A Voltage-Controlled DSTATCOM for Power-Quality Improvement," IEEE Trans. Power Del., vol. 29, no. 3, pp. 1499-1507, Jun. 2014.

[10] S.-H. Ko, S. Lee, H. Dehbonei and C. Nayar, "Application of voltage- and current-controlled voltage source inverters for distributed generation systems," IEEE Trans. Energy Conv., vol. 21, no. 3, pp. 782-792, Sep. 2006.