

Power Flow Control in Distribution Network of Hybrid Power System



M Lakshminarayana

M.Tech (Electrical Power Systems),
Department of EEE,
Adams Engineering College,
Paloncha, Telangana, India.



Medi Murali Krishna

Assistant Professor,
Department of EEE,
Adams Engineering College,
Paloncha, Telangana, India.



Kurivindala Ravi

Assistant Professor,
Department of EEE,
Sreenidhi Institute of Science Technology,
Hyderabad, Telangana, India.



Chilaka Udaya Kumar

Assistant Professor,
Department of EEE,
Anubose Institute of Technology,
Paloncha, Telangana, India.

Abstract:

Wind power generation studies of slow phenomena using a detailed model can be difficult to perform with a conventional offline simulation program. Due to the computational power and high-speed input and output, a real-time simulator is capable of conducting repetitive simulations of wind profiles in a short period of time. This paper discusses methods to overcome the challenges of real-time simulation of wind systems, characterized by their complexity and high-frequency switching.

A hybrid flow-battery super capacitor energy storage system (ESS), coupled in a wind turbine generator to smooth wind power, is studied by real-time simulation. This distributed controller is based on Multi Agent-System (MAS) technology. Fuzzy logic is used as a basic controller. The simulation results of the detailed wind system model show that the hybrid ESS has a lower battery cost, higher battery Longevity and improved overall efficiency over its reference ESS. Simulation is carried out using MATLAB software.

Keywords:

Fuzzy Logic, Distributed power, Hybrid Power System, power control, wind generator, Multi Agent-System (MAS).

I. INTRODUCTION:

Wind is abundant almost in any part of the world. Its existence in nature caused by uneven heating on the surface of the earth as well as the earth's rotation means that the wind resources will always be available. The conventional ways of generating electricity using non renewable resources such as coal, natural gas, oil and so on, have great impacts on the environment as it contributes vast quantities of carbon dioxide to the earth's atmosphere which in turn will cause the temperature of the earth's surface to increase, known as the green house effect. Hence, with the advances in science and technology, ways of generating electricity using renewable energy resources such as the wind are developed. Now a days, the cost of wind power that is connected to the grid is as cheap as the cost of generating electricity using coal and oil.

Thus, the increasing popularity of green electricity means the demand of electricity produced by using non renewable energy is also increased accordingly.

A. Features of wind power systems:

There are some distinctive energy end use features of wind power systems

- Most wind power sites are in remote rural, island or marine areas. Energy requirements in such places are distinctive and do not require the high electrical power.
- A power system with mixed quality supplies can be a good match with total energy end use i.e. the supply of cheap variable voltage power for heating and expensive fixed voltage electricity for lights and motors.
- Rural grid systems are likely to be weak (low voltage 33 KV). Interfacing a Wind Energy Conversion System (WECS) in weak grids is difficult and detrimental to the workers' safety.

There are always periods without wind. Thus, WECS must be linked energy storage or parallel generating system if supplies are to be maintained.

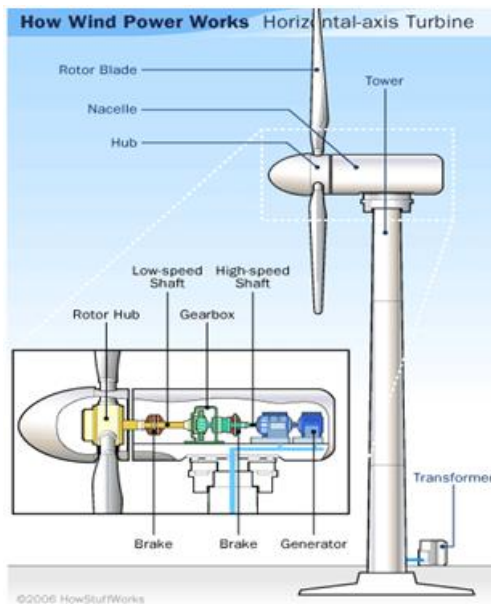

Fig. 1 Horizontal axis Turbine

However, classical wind energy conversion systems work like passive generators. Because of the intermittent and fluctuant wind speed, they cannot offer any ancillary services to the electrical system in a microgrid application, where stable active- and

reactive-power requirements should be attributed to the generators.

B. Power from the Wind:

Kinetic energy from the wind is used to turn the generator inside the wind turbine to produce electricity. There are several factors that contribute to the efficiency of the wind turbine in extracting the power from the wind. Firstly, the wind speed is one of the important factors in determining how much power can be extracted from the wind. This is because the power produced from the wind turbine is a function of the cubed of the wind speed. Thus, the wind speed if doubled, the power produced will be increased by eight times the original power. Then, location of the wind farm plays an important role in order for the wind turbine to extract the most available power from the wind.

The next important factor of the wind turbine is the rotor blade. The rotor blades length of the wind turbine is one of the important aspects of the wind turbine since the power produced from the wind is also proportional to the swept area of the rotor blades i.e. the square of the diameter of the swept area. Hence, by doubling the diameter of the swept area, the power produced will be fourfold increased. It is required for the rotor blades to be strong and light and durable. As the blade length increases, these qualities of the rotor blades become more elusive. But with the recent advances in fibreglass and carbon-fibre technology, the production of lightweight and strong rotor blades between 20 to 30 meters long is possible. Wind turbines with the size of these rotor blades are capable to produce up to 1 megawatt of power. The relationship between the powers produced by the wind source and the velocity of the wind and the rotor blades swept diameter is shown below.

$$P_{\text{wind}} = \frac{\pi}{8} \rho D^2 v_{\text{wind}}^3$$

The derivation to this formula can be looked. It should be noted that some books derived the formula in terms of the swept area of the rotor blades (A) and the air density is denoted as ρ .

Wind power has the following advantages over the traditional power plants.

- Improving price competitiveness,
- Modular installation,
- Rapid construction,
- Complementary generation,
- Improved system reliability, and
- Non-polluting.

C. Power Management

Power management is a feature of some electrical appliances, especially copiers, computers and computer peripherals such as monitors and printers, that turns off the power or switches the system to a low-power state when inactive. In computing this is known as PC power management and is built around a standard called ACPI. This supersedes APM. All recent (consumer) computers have ACPI support.

D. Motivation of Power Management:

PC power management for computer systems is desired for many reasons, particularly:

- Reduce overall energy consumption
- Prolong battery life for portable and embedded systems
- Reduce cooling requirements
- Reduce noise.
- Reduce operating costs for energy and cooling.

Lower power consumption also means lower heat dissipation, which increases system stability, and less energy use, which saves money and reduces the impact on the environment.

E. Hybrid Power Systems

Electrical energy requirements for many remote applications are too large to allow the cost-effective use of stand-alone or autonomous PV systems. In these cases, it may prove more feasible to combine several different types of power sources to form what is known as a "hybrid" system. To date, PV has been effectively combined with other types of power generators such as wind, hydro, thermoelectric, petroleum-fuelled and even hydrogen. The selection process for hybrid power source types at a given site can include a combination of many factors including site topography, seasonal availability of energy sources, cost of source implementation, cost of energy storage and delivery, total site energy requirements, etc.

Hydrogen technologies, combining fuel cells (FCs) and electrolyzers (ELs) with hydrogen tanks are interesting for long term energy storage because of the inherent high mass-energy density. In the case of wind energy surplus, the EL converts the excess energy into H₂ by electrochemical reaction. The produced H₂ can be stored in the hydrogen tank for future reutilization. In the case of wind energy deficit, the stored electrolytic H₂ can be reused to generate electricity by an FC to meet the energy demand of the grid. Thus, hydrogen, as an energy carrier, contributes directly to the reduction of dependence on imported fossil fuel. In this paper, each device is assumed to be interfaced through an electrical converter. Thereby, the agents are the controllers that determine the amount of power and energy exchanged by the element with the rest of the system.

II. FUZZY LOGIC

In recent years, the number and variety of applications of fuzzy logic have increased significantly. The applications range from consumer products such as cameras, camcorders, washing machines, and microwave ovens to industrial process control, medical instrumentation, decision-support systems, and portfolio selection. To understand why use of fuzzy logic has grown, you must first understand what is meant by fuzzy logic. Fuzzy logic has two different meanings. In a narrow sense, fuzzy logic is a logical system, which is an extension of multivalve logic. However, in a wider sense fuzzy logic (FL) is almost synonymous with the theory of fuzzy sets, a theory which relates to classes of objects with unsharp boundaries in which membership is a matter of degree. In this perspective, fuzzy logic in its narrow sense is a branch of fl. Even in its more narrow definition, fuzzy logic differs both in concept and substance from traditional multivalve logical systems.

1) Why use fuzzy logic?

Fuzzy logic is a convenient way to map an input space to an output space. Mapping input to output is the starting point for everything. Consider the following examples:

- With information about how good your service was at a restaurant, a fuzzy logic system can tell you what the tip should be.

- With your specification of how hot you want the water, a fuzzy logic system can adjust the faucet valve to the right setting.
- With information about how far away the subject of your photograph is, a fuzzy logic system can focus the lens for you.
- With information about how fast the car is going and how hard the motor is working, a fuzzy logic system can shift gears for you.

2) Building a Fuzzy Inference system

We can use Fuzzy Logic Toolbox software with MATLAB technical computing software as a tool for solving problems with fuzzy logic. Fuzzy logic is a fascinating area of research because it does a good job of trading off between significance and precision—something that humans have been managing for a very long time. Fuzzy inference is a method that interprets the values in the input vector and, based on user defined rules, assigns values to the output vector. Using the GUI editors and viewers in the Fuzzy Logic Toolbox, you can build the rules set, define the membership functions, and analyse the behaviour of a fuzzy inference system (FIS). The following editors and viewers are provided.

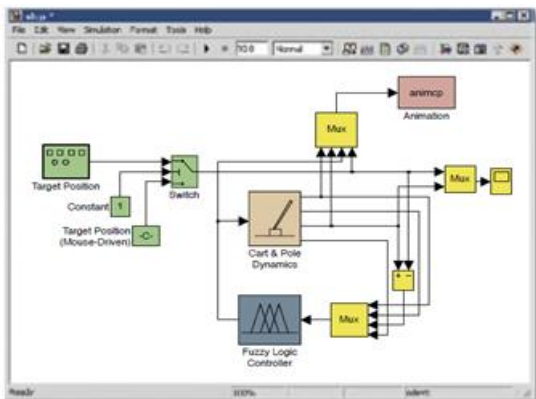

Fig. 2 Fuzzy Inference System

III. MULTI AGENT SYSTEM(MAS) THEORY

MAS theory is an emerging field that evolved from the distributed artificial intelligence (DAI) in the 1970s and 1980s. Since MAS theory represents the major stream of research in DAI, the two fields are often confused. MAS technology has been successfully applied in many fields like telecommunication, manufacturing, transportation, etc. Although MAS research is widespread, there is no precise definition about what an agent is.

Despite of the vague definition of agents, MAS theory generally specifies that they have the following main characteristics.

- Agents have a certain level of autonomy, which means that they can make decisions without a central controller.
- Agents are capable of acting in their environment, which means that they are able to perceive the changes in the environment in which they are immersed and then respond to those changes with their own actions whenever necessary.
- Agents have proactive ability, which means that they have their own goals and do not just act in response to changes that have occurred in their environments.
- Agents have social ability, which means that agents can communicate with one another.
- Agents have partial or no representation of the environment.

Based on these main features, the technology of intelligent agents and MASs is expected to alter radically the way in which complex, distributed, and open systems are conceptualized and implemented. Very intelligent agents are not necessarily needed; they can have a very simple individual behaviour. The most known example based on this paradigm is a colony of ants. Each ant, taken as an agent, does not have a very complex behaviour with an advanced reflection but the whole colony demonstrates an intelligent behaviour through adaptation and flexibility.

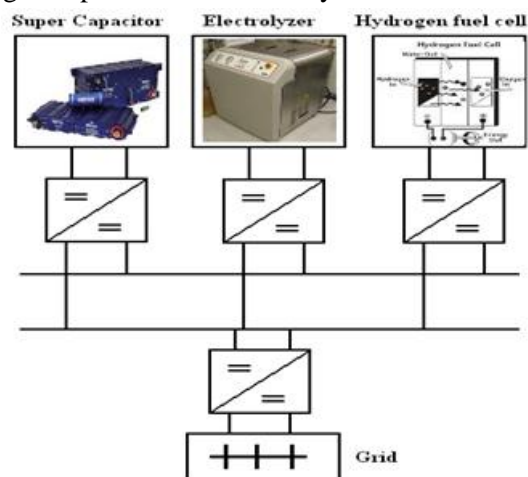

Fig. 3 Hybrid Power System Electrical Layout.

Therefore, the intelligent behaviour can emerge from the cooperation of very simple agents.

Due to the distributed, open, and complex nature of HES, the technology of MAS appears as a natural solution for the energy management purpose in HES. The agents act both competitively and cooperatively for achieving a global performance of the system; such performance can be defined by the following goals:

- a. to always supply the load;
- b. to minimize the operational cost ;
- c. to maximize the global efficiency.

In this paper, each device is assumed to be interfaced through an electrical converter.

Thereby, the agents are the controllers that determine the amount of power and energy exchanged by the element with the rest of the system.

i. Agents

“Agentification” is the approach used to understand the system as a collection of different elements called the agents. Agents are the controllers of the dc/dc converters. Unlike classical controllers, they have additional capabilities which make them “agents.” They decide on their own the power exchanged with the dc bus, which means that the information is not provided by a central controller. They can communicate, which means they know information coming from other agents and they also share information, for instance, about their capacity, their current state, and so on. It should be noticed that an agent is not obliged to share everything, and it does not have necessarily a complete representation of the other agents.

ii. Environment

An MAS is a set of agents which interact in a common environment. Consequently, the MAS approach implies to define an environment shared by the agents. For instance, in the application of lunar-explorer robots (where robots are agents), the environment is the moon. In the studied HES shown in Fig. 1, all the elements are linked through the dc bus that consists of a large SC. Therefore, the dc bus appears as the common environment shared by all the elements constituting the MAS. For practical purpose, the environment is the state of charge (SOC) of the SC. This information is accessible by all the agents, and they can act in this environment.

iii. “Blackboard” for Communications

Communication and sharing information is important to reach a global coordination. However, this communication is not necessarily direct between two agents. It can be performed using the principle of “blackboard.” Agents write their messages on a blackboard which can be read by all the agents as when someone leaves a message on the door of the fridge. In a more abstract concept of communication, agents would only modify their environment to communicate like ants leave Pheromones on the soil. The blackboard principle for communications was selected because it appeared to be promptly implemented and very efficient for this purpose. The blackboard contains all the information required by the agents to take their decision. Information is written by agents themselves. It helps agents to rise the level of knowledge that they have of their own environment and of the other agents. This is the core of the MAS technology, since the goal is to control a very complicated system with minimum data exchange and minimum computational demands.

iv. Production Agent

The Production agent has one goal for this purpose the Hydrogen technologies, combining fuel cells (FCs) and electrolyzers (ELs) with hydrogen tanks are interesting for long term energy storage because of the inherent high mass–energy density. In the case of wind energy surplus, the EL converts the excess energy into H₂ by electrochemical reaction. The produced H₂ can be stored in the hydrogen tank for future reutilization. In the case of wind energy deficit, the stored electrolytic H₂ can be reused to generate electricity by an FC to meet the energy demand of the grid.

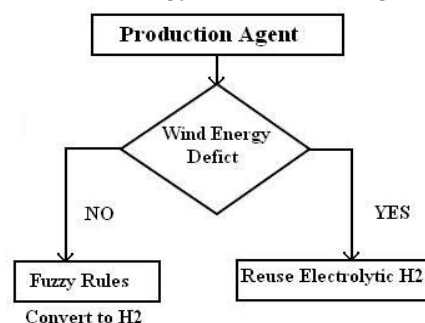

Fig. 4 Production Agent Behaviour

v. Load Agent

As the production agent, the load agent has two goals. First is to keep a constant voltage to the load, which can be performed using classic controller. The other one is to inform on the current load power using the blackboard.

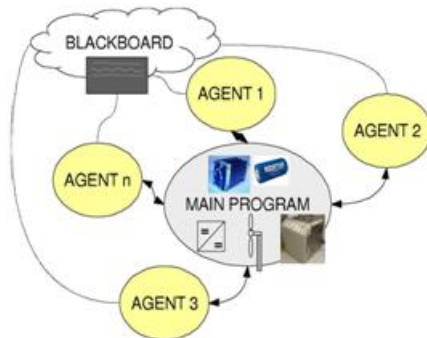

Fig. 5 Structure of the System

IV. HYBRID POWER SYSTEM AND CONTROL SYSTEM

A. Structure of HPS

In this paper, we use a dc-coupled structure in order to decouple the grid voltages and frequencies from other sources. All sources are connected to a main dc bus before being connected to the grid through a main inverter (Fig. 2). Each source is electrically connected with a power-electronic converter in order to get possibilities for power control actions. Moreover, this HPS structure and its global control system can also be used for other combinations of sources.

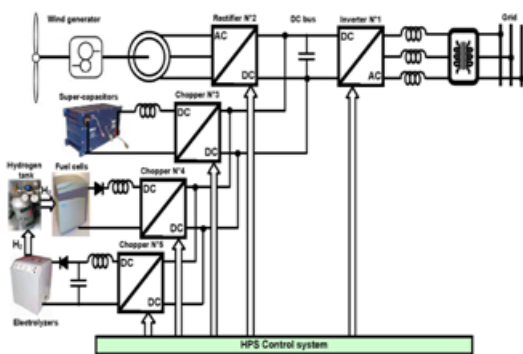

Fig.2. Structure of the studied wind/hydrogen/SC HPS.

B. Structure of Control System

Power converters introduce some control inputs for power conversion. In this case, the structure of the control system can be divided into different levels (Fig. 3).

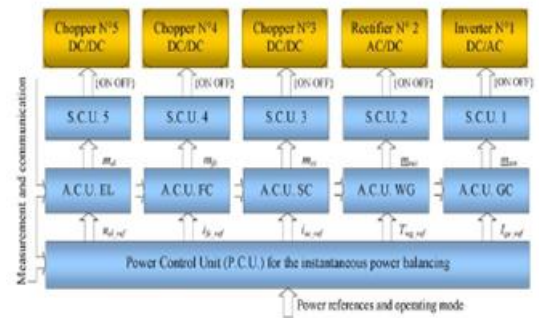

Fig. 6 Hierarchical control structure of the HPS]

The **switching control unit (SCU)** is designed for each power converter. In an SCU, the drivers with optocouplers generate the transistor's ON/OFF signals from the ideal states of the switching function {0, 1}, and the modulation technique (e.g., pulse width modulation) determines the switching functions from the modulation functions (m). The **automatic control unit (ACU)** is designed for each energy source and its power conversion system. In an ACU, the control algorithms calculate the modulation functions (m) for each power converter through the regulation of some physical quantities according to their reference values. The **power control unit (PCU)** is designed to perform the instantaneous power balancing of the entire HPS in order to satisfy the grid requirements. These requirements are real- and reactive-power references, which are obtained from the secondary control center and from references of droop controllers. In a PCU, some power-balancing algorithms are implemented to coordinate the power flows of different energy sources. The different power-balancing algorithms correspond to a number of possible operating modes of the HPS and can be gathered.

C. ACU

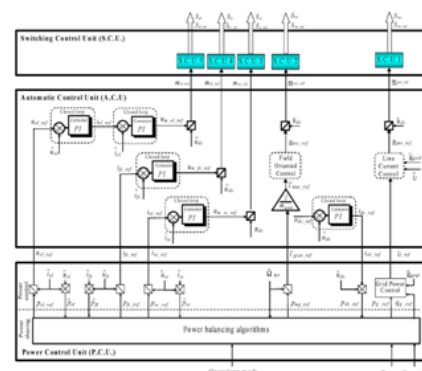

Fig. 7 Modelling and control of the HPS by the Energetic Macroscopic Representation.

The control schemes in the ACUs are shown in Fig. 4 with block diagrams.

- 1) The **EL power conversion system** is controlled by setting the terminal voltage (u_{el}) equal to a prescribed reference (u_{el_ref}) through the dc chopper N°5. The EL stack is considered as an equivalent current source (i_{el}).
- 2) The **FC power conversion system** is controlled with a reference of the FC current (i_{fc_ref}) through the dc chopper N°4. The FC stack is considered as an equivalent voltage source (u_{fc}).
- 3) The **SC power conversion system** is controlled with a current reference (i_{sc_ref}) through the dc chopper N°3. The SC bank is considered as an equivalent voltage source (u_{sc}).
- 4) The **wind energy conversion system** is controlled with a reference of the gear torque (T_{gear_ref}) by the three-phase rectifier N°2.
- 5) The **grid connection system** consists of a dc-bus capacitor and a grid power conversion system. The grid power conversion system is controlled with line-current references (i_{l_ref}) by the three-phase inverter N°1, because the grid transformer is considered as an equivalent voltage source (u_{grid}).

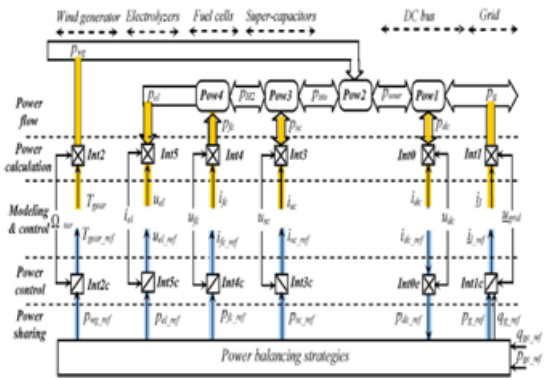

Fig. 8 Multilevel representation of the power modeling and control of the HPS.

b) Power Control Level:

The power exchanges with various sources are controlled only via the related five references (u_{el_ref} , i_{fc_ref} , i_{sc_ref} , T_{gear_ref} , and i_{l_ref} in Fig. 8).

TABLE:I SUMMARY OF EQUATIONS FOR POWER CALCULATION

	Power calculation	Power control
DC	Int0: $p_{dc} = u_{dc} i_{dc}$	Int0c: $p_{dc_ref} = u_{dc} i_{dc_ref}$
GC	Int1: $\begin{cases} p_g = u_{13} i_1 + u_{23} i_2 \\ q_g = \sqrt{3}(u_{13} i_1 - u_{23} i_2) \end{cases}$	Int1c: $\begin{cases} i_{1_ref} = \frac{(2u_{13} - u_{23})p_{g_ref} + \sqrt{3}u_{23}q_{g_ref}}{2u_{13}^2 - 2u_{13}u_{23} + 2u_{23}^2} \\ i_{2_ref} = \frac{(2u_{23} - u_{13})p_{g_ref} - \sqrt{3}u_{13}q_{g_ref}}{2u_{13}^2 - 2u_{13}u_{23} + 2u_{23}^2} \end{cases}$
WG	Int2: $p_{wg} = \Omega_{gear} T_{gear}$	Int2c: $T_{gear_ref} = p_{wg_ref} / \Omega_{gear}$
SC	Int3: $p_{sc} = u_{sc} i_{sc}$	Int3c: $i_{sc_ref} = p_{sc_ref} / u_{sc}$
FC	Int4: $p_{fc} = i_{fc} u_{fc}$	Int4c: $i_{fc_ref} = p_{fc_ref} / u_{fc}$
EL	Int5: $p_{el} = i_{el} u_{el}$	Int5c: $u_{el_ref} = p_{el_ref} / i_{el}$

Therefore, the expressions of the powers should be deduced in order to obtain these power references (Table I). Only the sources' powers and the exchanged power with the dc-bus capacitor are taken into account here. For the energy storage systems, the powers are calculated by multiplying the measured currents and the measured voltages (Int3, Int4, and Int5 in Table I). The references of the controllable variables are obtained by dividing the power reference with the measured current or the measured voltages (Int3c, Int4c, and Int5c in Table I). For the wind energy conversion system, a maximal-power-point-tracking (MPPT) strategy is used to extract the maximum power of the available wind energy according to a nonlinear characteristic in function of the speed.

The dc-bus voltage is described as

$$C_{dc} \frac{du_{dc}}{dt} = i_{dc} \dots \dots \dots (1)$$

In order to control the dc-bus voltage, a voltage controller must be used. The output of the voltage controller is a current reference i_{dc_ref} .

D. PCU

a) Layout of PCU:

The power modelling of the HPS can be divided into two levels: the **power calculation level** and the **power flow level** (Fig. 8). Thus, the PCU is also divided into two levels: the **power control level** and the **power sharing level**. The PCU enables one to calculate references for the ACU from power references. The power sharing level coordinates the power flow exchanges among the different energy sources with different power-balancing strategies. They are presented here in detail with the help of the Multilevel Representation (Fig. 5), which was developed by Peng Li in 2008.

It receives the measured rotational speed (Ω_{tur}) and sets a desired power reference (p_{wg_ref}) (Int2 and Int2c in Table I). The output of the dc-bus voltage control loop is the current reference (idc_ref) of the dc-bus capacitor, and its product with the measured dc-bus voltage gives the power reference (p_{dc_ref}) for the dc-bus voltage regulation (Int0e). The powers, which are exchanged with the grid, can be calculated with the “two-wattmeter” method (Int1 and Int1c in Table I). In order to focus on the power exchanges with the different sources around the dc bus, the instantaneously exchanged power with the choke, the losses in the filters, and the losses in the power converters are neglected.

c) Power Sharing Level:

The power sharing level is used to implement the power balancing strategies in order to coordinate the various sources in the HPS (Fig. 5). It plays a very important role in the control system, because the power exchanges lead directly to the stability of the HPS and impact the dc-bus voltage (u_{dc}).

$$\frac{dE_{dc}}{dt} = C_{dc}u_{dc} \frac{du_{dc}}{dt} = p_{dc} = p_{wg} + p_{sc} + p_{fc} - p_{el} - p_g \dots\dots\dots (2)$$

With

- E_{dc} stored energy in the dc-bus capacitor;
- p_{dc} resulted power into the dc-bus capacitor;
- p_{wg} generated power from the WG;
- p_{fc} generated power from the FC;
- p_{sc} exchanged power with the SC;
- p_{el} consumed power by the EL;
- p_g delivered power into the grid from the dc bus.

According to the power exchange, the power flows inside this HPS are modelled with four equations.

$$Pow1 : p_g = p_{sour} - p_{dc} \dots\dots\dots (3)$$

$$Pow2 : p_{sour} = p_{sto} + p_{wg} \dots\dots\dots (4)$$

$$Pow3 : p_{sto} = p_{H2} + p_{sc} \dots\dots\dots (5)$$

$$Pow4 : p_{H2} = p_{fc} - p_{el} \dots\dots\dots (6)$$

With

- p_{sour} “source” total power arriving at the dc bus;
- p_{sto} “storage” total power arriving at the dc bus;
- p_{H2} “hydrogen” total power arriving at the dc bus.

In this wind/hydrogen/SC HPS, five power-electronic converters are used to regulate the power transfer with

each source. According to a chosen power flow, the following two power balancing strategies can be implemented.

- 1) The **grid-following strategy** uses the line-current loop to regulate the dc-bus voltage.
- 2) The **source-following strategy** uses the line-current loop to control the grid active power, and the dc-bus voltage is regulated with the WG and storage units.

V. MAT LAB DESIGN OF CASE STUDY AND RESULTS

The proposed MAS has been implemented using MATLAB software. Usually, object-oriented languages, like C++ or Java, are used to develop MAS. An agent-oriented language does not exist, and object-oriented language is preferred because it has some similarities with the agent approach. However, MATLAB has been used because it is widely applied in electrical and power engineering to control applications, and it features a very convenient fuzzy-logic toolbox.

i. Block diagram of source following:

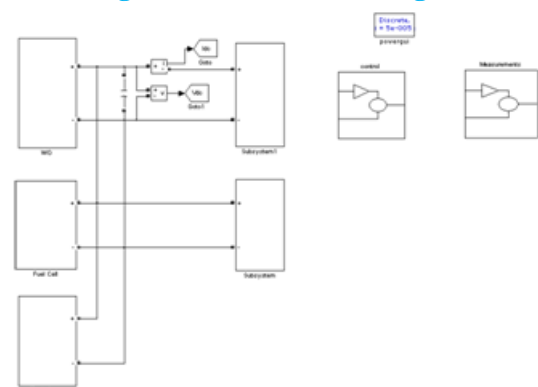

Fig. 9 Block diagram for Source following

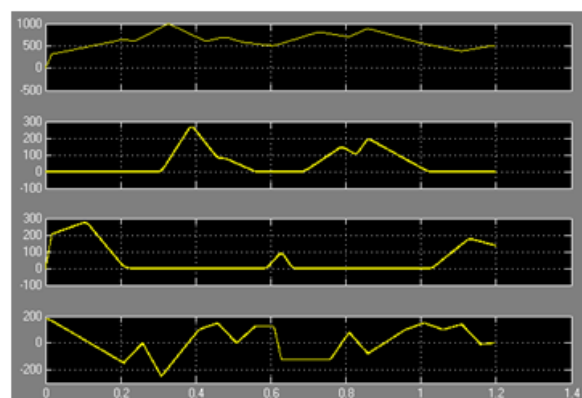

Fig. 10 Power profile for different sources

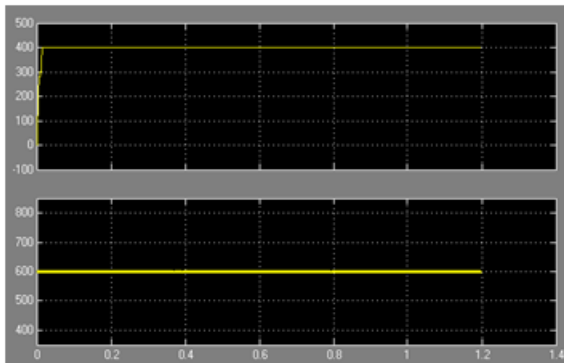

Fig. 11 Output waveforms of Dc bus voltage V and grid active power P_g

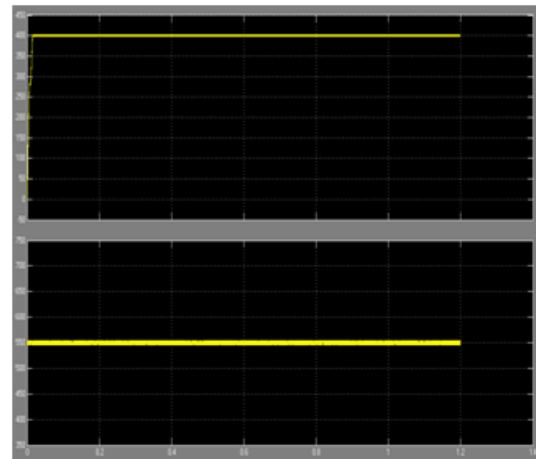

Fig. 13 Output waveforms of Dc bus voltage V and grid active power P_g

ii. Block diagram of grid following:

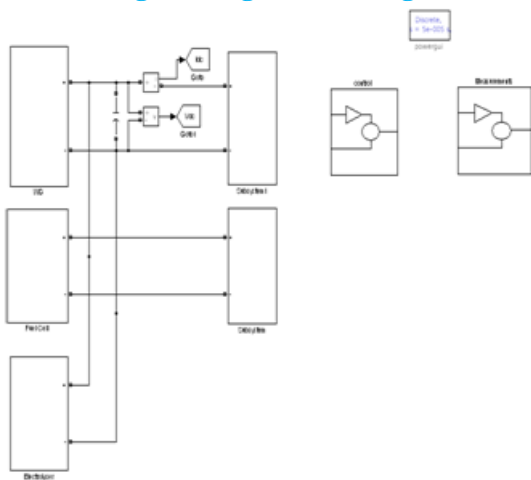

Fig. 11 Block diagram for Source following

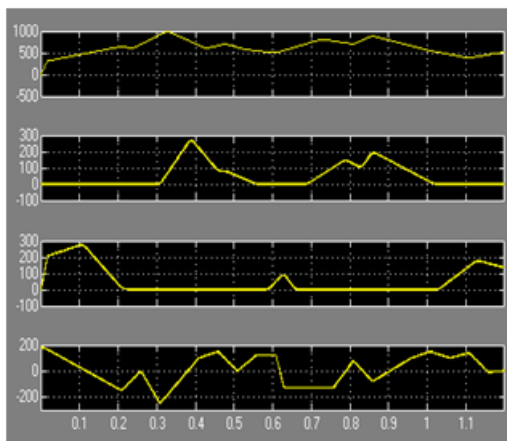

Fig. 12 Power profile for different sources

VI. CONCLUSIONS

In this paper, The MAS approach and the agents' behaviors have been detailed. The system reaction has been observed through a simulation model, and it has been demonstrated that the proposed EMS is able to adapt its response even for changing configurations. A dc-coupled HPS has been studied with the three kinds of energy sources: 1) a WG as a renewable energy generation system; 2) SCs as a fast-dynamic energy storage system; and 3) FCs with ELs and hydrogen tank as a long term energy storage system. The structure of the control system is divided into three levels: 1) SCU; 2) ACU; and 3) PCU. Two power-balancing strategies have been presented and compared for the PCU: the grid-following strategy and the source following strategy. For both of them, the dc-bus voltage and the grid power can be well regulated. The experimental tests have shown that the source-following strategy has better performance on the grid power regulation than the grid-following strategy with Fuzzy Logic.

REFERENCES:

[1] Tao Zhou and Bruno François, Senior Member, IEEE "Energy Management and Power Control of a Hybrid Active Wind Generator for Distributed Power Generation and Grid Integration" IEEE Transactions On Industrial Electronics, Vol. 58, No. 1, January 2011.

[2] Jérémy Lagorse, Marcelo G. Simões, Senior Member, IEEE, and Abdellatif Miraoui "A Multiagent

Fuzzy-Logic-Based Energy Management of Hybrid Systems “IEEE Transactions On Industry Applications, Vol. 45, No. 6, November/December 2009.

[3] W. Li, G. Joos, and J. Belanger, “Real-time simulation of a wind turbine generator coupled with a battery super capacitor energy storage system,” IEEE Trans. Ind. Electron., vol. 57, no. 4, pp. 1137–1145, Apr. 2010.

[4] G. Delille and B. Francois, “A review of some technical and economic features of energy storage technologies for distribution systems integration,” Ecol. Eng. Environ. Prot., vol. 1, pp. 40–49, 2009.

[5] C. Abbey and G. Joos, “Super capacitor energy storage for wind energy applications,” IEEE Trans. Ind. Electron., vol. 43, no. 3, pp. 769–776, May 2007.

[6] G. Taljan, M. Fowler, C. Cañizares, and G. Verbić, “Hydrogen storage for mixed wind-nuclear power plants in the context of a Hydrogen Economy,” Hydrogen Energy, vol. 33, no. 17, pp. 4463–4475, Sep. 2008.

[7] M. Little, M. Thomson, and D. Infield, “Electrical integration of renewable energy into stand-alone power supplies incorporating hydrogen storage,” Hydrogen Energy, vol. 32, no. 10, pp. 1582–1588, Jul. 2007.

[8] T. Zhou, D. Lu, H. Fakham, and B. Francois, “Power flow control in different time scales for a wind/hydrogen/super-capacitors based active hybrid power system,” in Proc. EPE-PEMC, Poznan, Poland, Sep. 2008, pp. 2205–2210.

[9] F. Baalbergen, P. Bauer, and J. A. Ferreira, “Energy storage and power management for typical 4Q-load,” IEEE Trans. Ind. Electron., vol. 56, no. 5, pp. 1485–1498, May 2009.

[10] D. Ipsakis, S. Voutetakis, P. Seferlis, F. Stergiopoulos, and C. Elmasides, “Power management strategies for a stand-alone power system using renewable energy sources and hydrogen storage,”

Hydro. Energy, vol. 4, no. 16, pp. 7081–7095, Aug. 2009.

[11] U.S. Department of Energy, Energy Efficiency and Renewable Energy, Wind & Hydropower Technologies Program, Wind Energy Research Area.

[12][Online]. Available:<http://www.eere.energy.gov/>

[13][Online]. Available: <http://www.eurobserv-er.org/>