

## **An Efficient IC Layout Design of Decoders and Its Applications**

**Dr. Arvind Kundu****HOD,****SCIENIT Institute of Technology.****T. Uday Bhaskar, M.Tech****Assistant Professor,****SCIENIT Institute of Technology.****B. Suresh****M.Tech (VLSI & ES)****SCIENIT Institute of Technology.**

### **Abstract:**

Low power issues have become an important factor in modern VLSI design. This paper discusses the design of an Integrated Circuit (IC) layout for a decoder. The decoders are designed by using Schematic and Layout editor tools DSCH3.5 and Microwind3.5. In order to produce the schematic and layout, the basic knowledge of fabrication process and IC design rules are expounded. The complete layout of the decoder was designed based on its schematic circuit, which consists of NOT gates, 2-input NAND gates, 3-input NAND gates, 4-input NAND gates, 2-input AND gates and 3-input AND gates. The layout had undergone Design Rule Check (DRC) set by the DSCH3.5 to check for any design rule error. Both layout and schematic circuit of the decoder were simulated through DSCH3.5 and Microwind3.5 to ensure they were identical with 65nm. DSCH is used as simulator to carry out the simulation work and verify the validity of the function. The simulation output indicated that results of the layout and schematic circuit for decoder were essentially identical and matches the theoretical results.

### **Index Terms:**

Decoder, schematic circuit, IC layout, DSCH3.5 and Microwind3.5, NAND gates, AND gates and simulation output.

### **I. INTRODUCTION:**

Electronic devices have been widely used in many different fields and the size of these devices has been gradually reduced.

An example of this is the mobile phone which is made smaller to enhance user's mobility and usage time. These are the contribution of integrated circuit (IC) technology. With this technology, the modern devices have been reduced to convenient sizes. Besides that, mass production of IC has lowered the cost of production and made most electronic devices affordable. Today, an IC is smaller than a coin and can hold millions of transistors. Hence, further research in the design of IC is important to enhance the production of a more efficient and viable IC. The main objective of this paper is to design an IC layout of a 7-segments decoder by Microwind3.5 and DSCH3.5. The tools are Schematic and Layout editor tools that provides service in handling IC layout, schematic drawing, textual hardware description language, and other features [1]. By using this software's, a micrometer sized IC can be easily designed due to the availability of various features that can be used to design and check the IC layout. Moreover, DSCH3.5 and Microwind3.5 also allows the schematic and layout design to be done in a systematic and efficient manner, thus saving time and reducing the production cost of the IC chip. There are different technologies to construct integrated circuits such as bipolar integrated technology, NMOS technology and CMOS technology. In this project, CMOS technology is used. The main reason in using CMOS technology is due to its scalable high noise immunity and low power consumption. Basically, CMOS technology uses both NMOS and PMOS, which means only either one of both types of transistors will be ON at a time during the operation.

Thus, CMOS IC consumes less power as power is used only when the NMOS and PMOS transistors are switching between on and off states [2].

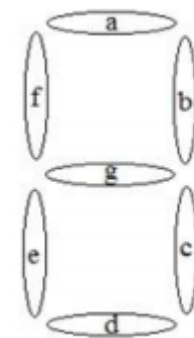
**II. LITERATURE REVIEW:**

In present scenario, power reduction is a major issue in the technology world. The low power design is major issue in high performance digital system, such as microprocessors, digital signal processors (DSPs), 7-Segments display and other applications. The chip density and higher operating speed leads to the design of very complex chips with high clock frequencies. So designing of low power VLSI circuits is a technological need in these due to the high demand for portable consumer electronics products [2]. The development of electronic technology was started with the use of vacuum tube as active component in electronic series before semiconductor transistor replaces it. The development of microelectronic technology especially for those of mono-lithical is able to produce interfaced circuit by combining all active and passive components in one chip [3]. High speed serializer/deserializers (SerDes) are now more and more widely used in communication systems for serial interconnections [4]. Decoders are used whenever an output or a group of outputs is to activated only on the occurrence of specific combination of input levels. These input levels are often provided by the outputs of a counter or register. When the decoder inputs come from a counter that is being continually pulsed, the decoder outputs will be activated sequentially, and they can be used as timing or sequencing the signals to turn devices ON or OFF at specific times. Decoders are widely used in memory systems of computers, where they respond to the address code input from the central processor to activate the memory storage location specified by the address code [1].

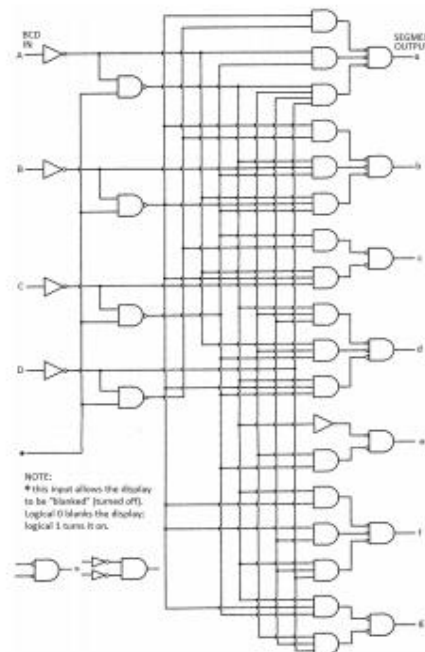
**A. 7-Segments Decoder:**

A 7-segments decoder is able to convert the logic states of inputs into seven bits of outputs and displays in 7-segments display. It is used widely in devices where its main function is to display numbers from a

digital circuitry. Examples of these devices includes calculators, displays in elevator, digital timers, digital clocks and etc. There are many types of decoders such as 2-4 decoder, 3- 8 decoder and 4-16 decoder. Since there are ten decimal numerals (0-9) to be displayed in the 7-segments display, a 4-16 decoder was used. The structure of a 7-segments display is shown in Fig. 1. It is used to display decimal numerals in seven segments and each segment is represented by an alphabet ‘a’ to ‘g’. By setting the required segments to be turned on, the desired decimal numeral can be displayed on the 7-segments display. The logic diagram of 7-segments decoder is shown in Fig. 2.



**Figure 1. Structure of a 7-segments display**



**Figure 2. The logic diagram of a 7-segments decoder [3]**

## B. IC Design rules:

IC layouts are built from three basic components which are the transistors, wires and vias. During the design of the layouts, the design rule has to be considered. Design rules govern the layout of individual components and the interaction between those components. When designing an IC, designers tend to make the components as small as possible enabling implementation of as many functions as possible onto a single chip. However, since the transistors and wires are extremely small, errors may happen during the fabrication process. Hence, design rules are created and formulated to minimise problems during fabrication process and helps to increase the yield of correct chips to a suitable level. Therefore, it is important to adhere to the design rules during layout design.

## C. Physical Verification of Design [1], [4]

Physical verification is a process where an IC layout design will be checked via DSCH3.5 and Microwind3.5 EDA tools to ensure it meets design criteria and rules. The verification process used in this project involves DRC (Design Rule Check) and ERC (Electrical Rule Check). These are important procedures in IC layout design and cannot be treated lightly.

i) Design Rule Check (DRC) DRC is a verification process that determines whether the physical layout of a chip design satisfies the Design Rules or not. It ensures that all the polygons and layers meet the manufacturing process rules that defines the limits of a manufacturing design such as the width and space rules. DRC is the first level of verification once the layout is ready. In this verification stage, the connectivity and guidelines rules will be checked as well. DRC will not only check the designs that are created by the designers, but also the design placed within the context in which it is going to be used. Therefore, the possibility of errors in the design will be greatly reduced and a high overall yield and reliability of design will be achieved.

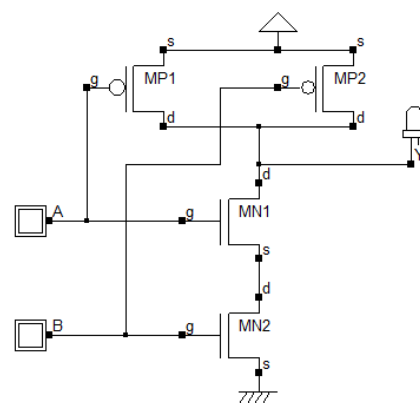
ii) Electrical Rules Check (ERC) ERC is usually used to check the errors in connectivity or device connection. It is an optional choice of checking and seldom used as an independent verification step. ERC is usually used to check for any unconnected, partly connected or redundant devices. Also, it will check for any disabled transistors, floating nodes and short circuits. ERC is very useful in accelerating debugging problems such as short circuits as can speed up the design process.

## III. Decoder IC basic Elements:

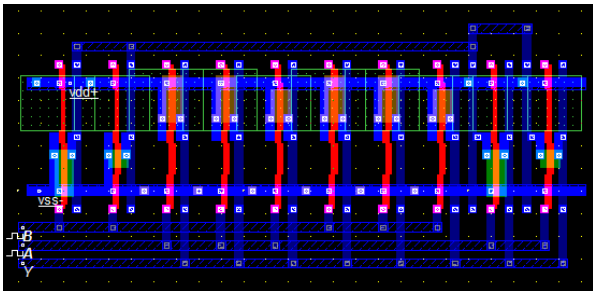
In this project, an IC layout of a decoder that displays the decimal numeral in 7-segments display was designed. It consists of NOT gates, 2-input NAND gates, 3-input NAND gates, 4-input NAND gates, 2-input AND gates and 3-input AND gates. The schematic circuits and layouts of all these gates were drawn and simulated using DSCH3.5 and Microwind3.5.

### A. 2-Input NAND Gates:

Fig. 3 and Fig. 4 shows the schematic diagram and layout design of a 2-input NAND gate DSCH3.5 and Microwind3.5.



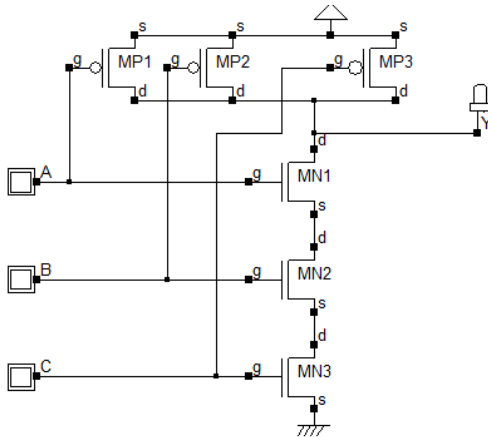
**Figure 3. Schematic diagram of a 2-input NAND gate**



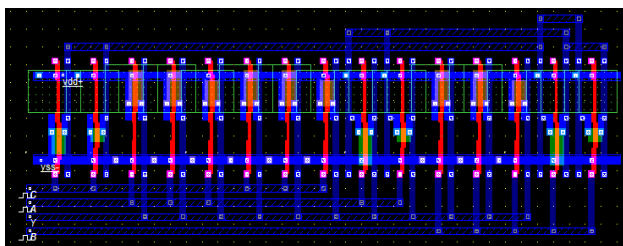
**Figure 4. Layout design of 2-input NAND gate**

**B. 3-Input NAND Gates:**

Fig. 5 and Fig. 6 show the schematic diagram and layout of a 3-input NAND gate.



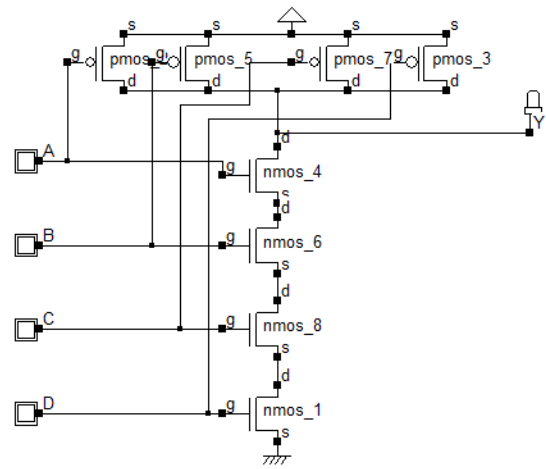
**Figure 5. Schematic diagram of a 3-input NAND gate**



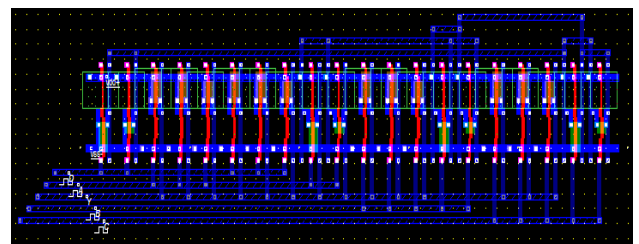
**Figure 6. Layout design of a 3-input NAND gate**

**C. 4-Input NAND Gates:**

Fig. 7 and Fig. 8 show the schematic diagram and layout of a 4-input NAND gate, respectively.



**Figure 7. Schematic diagram of 4-input NAND gate**



**Figure 8. Layout design of 4-input NAND gate**

Fig. 9 shows the 4-input NAND gate symbol and symbol input and outputs. The symbol was required and used to complete the simulation process. The input wire are named as 'a', 'b', 'c' and 'd'; whereas output wire is named as 'y'. Simulation result of the 4-input NAND gate is shown in Fig. 10. If all the inputs of the 4-input NAND gate are '1', the output will be '0'. Meanwhile, whenever there is '0' among the inputs, the output will be '1'. In addition, due to the capacitance, the fall in the waveform actually indicates a logic '0' whereas the rise in waveform indicates a logic '1'. From the waveform generated, as shown in Fig. 10, the results are match with the theoretical 4-input NAND gate. It can be deduced that the 4-input NAND gate drawn by using DSCH3.5 and Microwind3.5 operates correctly.

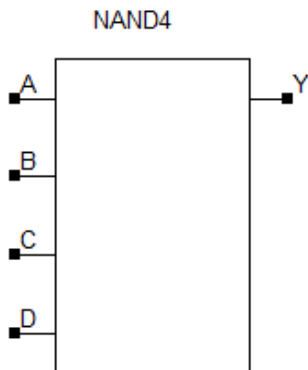


Figure 9. Icon of 4-input NAND gate and spice code

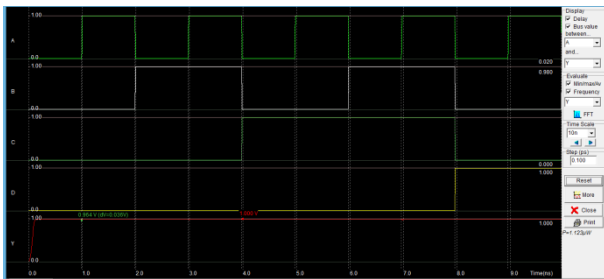


Figure 10. Simulation result of the 4-input NAND gate

#### IV. IC DESIGN METHODOLOGY:

The schematic circuit of the 7-segments decoder was drawn and debugging process had been carried out to ensure the design is error free. In this project, the layout of the 7-segments decoder was designed using DSCH3.5 and Microwind3.5 to exploit its powerful editing tools. DSCH3.5 and Microwind3.5 tools are high performance EDA tool that provides complete aids in designing the IC schematic and layout. It integrates the schematic editor, circuit simulator, schematic driven layout generator, layout editor, layout verification and parasitic extraction. Besides that, Microwind3.5 IV simulation software was also used in this project. It is a high performance simulator that provides a schematic capture and waveform viewer. It is used to simulate the outputs of both schematic circuit and layout during DRC. There are basic design rules to be followed in order to design an IC layout successfully.

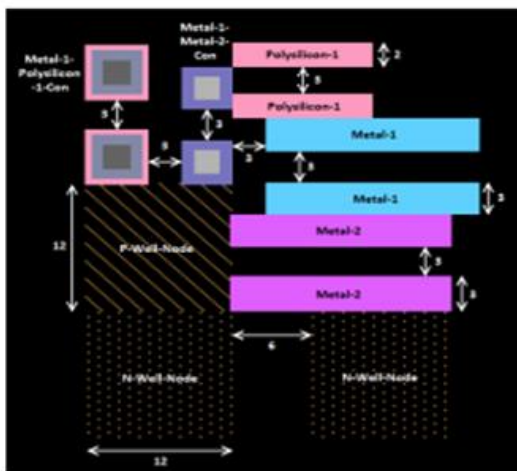
These rules uses a universal parameter,  $\lambda$ . Fig. 11 shows the basic design rules commonly used in Microwind3.5.

TABLE I. LIST OF FUNDAMENTAL RULE OF DESIGNING AN IC LAYOUT [7]

<b>Well</b>	
Minimum well size	12 $\lambda$
Between wells	6 $\lambda$
Between N-well and P-well	6 $\lambda$
Minimum well area	144 $\lambda^2$
<b>Polysilicon1</b>	
Polysilicon1 width	2 $\lambda$
Between polysilicon1s	3 $\lambda$
Between polysilicon1 and metal	N/A
Minimum polysilicon1 area	4 $\lambda^2$
<b>Polysilicon2</b>	
Polysilicon2 width	7 $\lambda$
Between polysilicon2s	3 $\lambda$
Between polysilicon2 and metal	N/A
Minimum polysilicon2 area	49 $\lambda^2$
<b>Metal1,2,3,4,5</b>	
Metal width	3 $\lambda$
Between metals	3 $\lambda$
Between metal and other metal	N/A
Minimum metal area	9 $\lambda^2$
<b>Via1,2,3,4</b>	
Via width	2 $\lambda$
Minimum via area	4 $\lambda^2$
<b>Metal6</b>	
Metal6 width	5 $\lambda$
Between metal6s	5 $\lambda$
Between metal6 and other metal	N/A
Minimum metal6 area	25 $\lambda^2$
<b>Via5</b>	
Via5 width	3 $\lambda$
Minimum via5 area	9 $\lambda^2$

Table I shows the basic design rule in a list. As shown in Fig. 11, the minimum distance between two same

metals or polysilicons must be at least  $3\lambda$ . Besides, the width of metal from 1 to 5 must be at least  $3\lambda$  wide. Notice that in Table I, some parameter's rule are labelled as 'N/A'. This is because there are not such spacing rules. In other words, the respective components can be placed overlapping each other. Also, there are rules where the parameter is  $0\lambda$ . This indicates that the respective components can be placed side by side without any space in between. There is also no minimum distance between vias or with other components listed in the table. This is because the vias available in Microwind3.5 are combined with 2 metals, covering every side of the vias. Therefore, before the vias can be placed nearer to each other, the metal surrounding it will connect each other first. The distance between the metal of vias has to obey the rules before the vias have the chance of contact. In other words, it also indicates that the minimum distance between vias or with other components can be determined through the metal's rule.

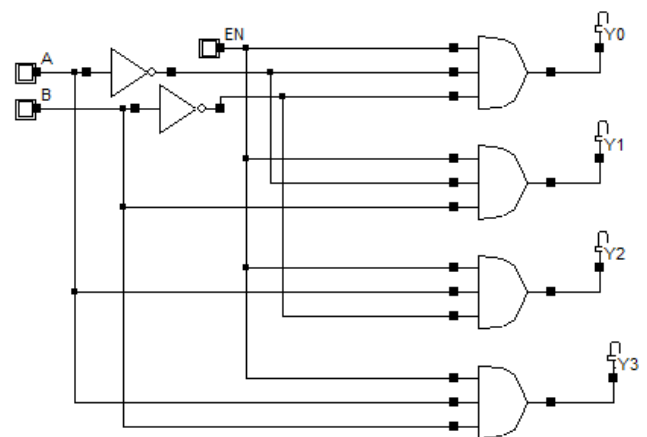


**Figure 11. Fundamental rule of designing an IC layout (All values are in lambda) [7]7-Segment Decoder**

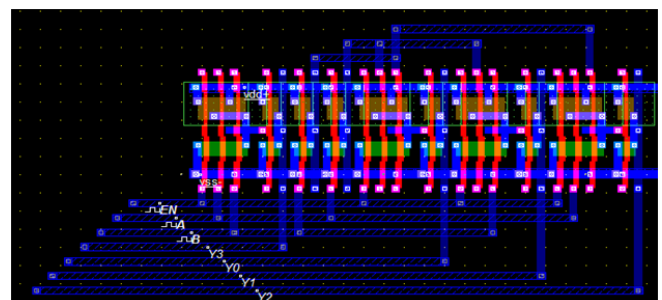
### V.LAYOUT SIMULATION:

In this section, performance analysis of decoder has been presented. Designs simulations are done using DSCH3.5 and MICROWIND3.5 tools at foundry like 65nm. Packing and particular manufacturing process including every small features have been described through the layout design rule.

The designers have used different logic layers for layout generation. There are specific layers for metal, contacts or diffusion areas, polysilicon. Design red color presents polysilicon, green color indicates n+ diffusion, light green color indicates p+ diffusion, light and dark blue color within the layout designed. All the schematic diagrams and layouts of the basic gates drawn have to go through the physical verification process before simulation. These are the essential procedures to ensure the validity outputs results of the system. The 2to4 decoder schematic circuit and its IC layout was designed using Microwind3.5 tool, as shown in Fig. 12 and Fig. 13, respectively.

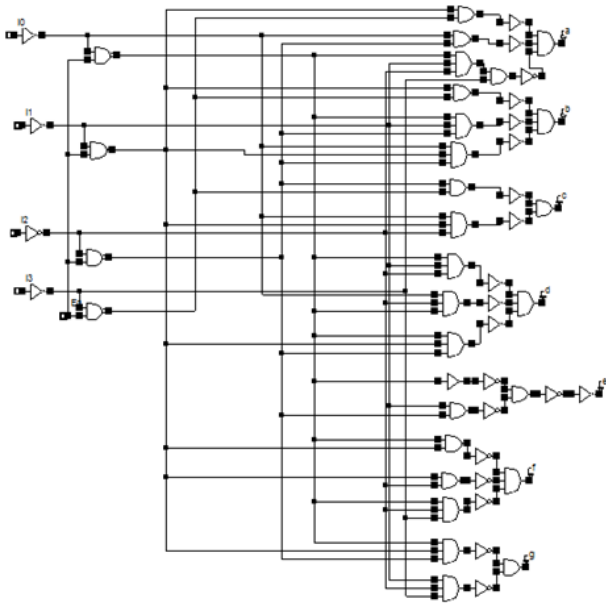


**Figure 12. Schematic diagram of 2to4 Decoder**

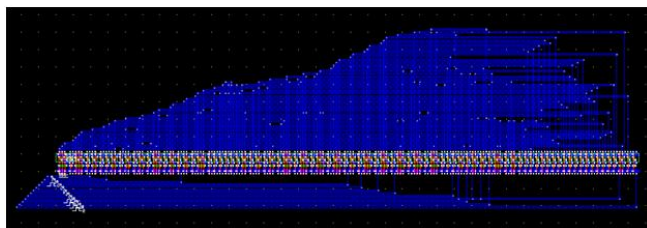


**Figure 13. Layout design of 2to4 Decoder**

Based on the logic diagram of 7-segment decoder, the schematic circuit and its IC layout was designed using Microwind3.5 tool, as shown in Fig. 14 and Fig. 15, respectively.



**Figure 14. Schematic diagram of a 7-segments decoder**

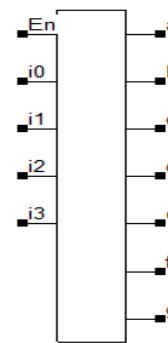


**Figure 15. IC layout design of decoder**

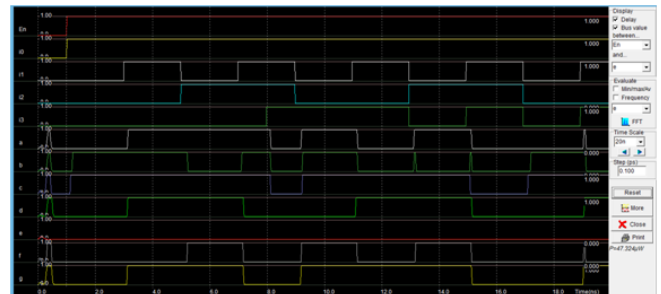
However, Fig. 16 shows the icon view of the decoder with spice code, which is ready for simulation. It shows the inputs and outputs port and also the spice code that specifies the input pulses of the decoder for simulation. There are five inputs: 'in\_0', 'in\_1', 'in\_2', 'in\_3' and 'sw', where 'in\_0' is the least significant bit and 'in\_3' is the most significant bit. Since it is a 7-segment decoder, seven outputs will be needed. These outputs are labelled as 'out\_a', 'out\_b', 'out\_c', 'out\_d', 'out\_e', 'out\_f' and 'out\_g'. Notice that there is a 'sw' input which represents the switch. When the switch is to '0', no matter what other inputs are, the outputs will always be '0'. When the switch is to '1', the outputs will be varied according to the binary combination of the inputs. Fig. 15 is the simulation waveform generated with different inputs.

It is known that as long as the 'sw' is off, the outputs will be '0'. This figure shows simulation waveform for when the 'sw' is off. In reference to the truth table of the binary-convert-decimal, as shown in Table II, the designed decoder is match with the theoretical work and said to function as expected.

SEGMENT7DISPLAY



**Figure 16. Icon of decoder and spice code**



**Figure 15. Simulation result of the 7-segments decoder**

**TABLE II. TRUTH TABLE OF BINARY-  
CONVERT-DECIMAL (BCD)**

No	INPUT				OUTPUT						
	in_3	in_2	in_1	in_0	a	b	c	d	e	f	g
0	0	0	0	0	1	1	1	1	1	1	0
1	0	0	0	1	0	1	1	1	0	0	0
2	0	0	1	0	1	1	0	1	1	0	1
3	0	0	1	1	1	1	1	1	0	0	1
4	0	1	0	0	0	1	1	0	0	1	1
5	0	1	0	1	1	0	1	1	0	1	1
6	0	1	1	0	0	0	1	1	1	1	1
7	0	1	1	1	1	1	1	0	0	0	0
8	1	0	0	0	1	1	1	1	1	1	1
9	1	0	0	1	1	1	1	1	0	1	1

#### **VI CONCLUSION:**

The design and analysis of decoder and its 7-segment display has been presented. Designs simulations are done using DSCH3.5 and MICROWIND3.5 tools at foundry like 65nm. 7-segments decoder IC is to display the numbers in 7 segments. It converts the binary input to 7 bits according to the input. The IC layout of the decoder is designed and successfully proves that the output waveforms generated matches the theoretical decoder. In addition, DSCH3.5 and Microwind3.5 tools are user friendly software's to be used in designing a layout of 7-segments decoder. It is expected that the software's are able to cope with more complex digital IC design with its suite of verification and design tools.

#### **REFERENCES:**

- [1] About DSCH3.5 and Microwind3.5 (May 2014).  
[Online]. Available:  
<http://www.microwind.net>
- [2] A. Anand Kumar, "Fundamentals of Digital Circuits" Second Edition, Prentice Hall of India, pp. 337-340, 2006.
- [3] Ranjan Kumar Singh, Rakesh Jain, "Implementation And Analysis of Power Reduction In 2 to 4 Decoder Design Using Adiabatic Logic", International Journal of Research in Engineering and Technology (IJRET) eISSN: 2319-1163, Volume-03 Issue-07, pp. 172-175, July 2014
- [4] R. J. Baker, CMOS: Circuit Design, Layout, and Simulation, John Wiley & Sons, 2010, pp. 6-12.
- [5] M. M. Forrest, Understanding Digital Computers, Radio Shack, 1987.
- [6] S. H. Teen and S. Y. Lee, "CMOS IC layout design: 7-segments counter," Lecture Notes on Photonics and Optoelectronics, vol. 1, no. 2, pp. 52-55, December 2013.

[7] A. P. Douglas and E. Kamran, Basic VLSI Design, 3rd ed., Prentice Hall, 1994, pp. 72-76.

#### **Author's Details:**

##### **Dr. Arvind Kundu**

He did B. Tech from H.P. University (SHIMLA) in Electronics & Communication. He did M. Tech from M.D. University (ROHTAK) in Electronics & Communication Engineering. He did Ph. D from Ranchi University and area of research is ADHOC Networks, EMBEDDED System, Cryptography, Message authentication Protocol, Image Processing, Routing protocol etc. He is working as HOD ECE Department at SCIENT INSTITUTE OF TECHNOLOGY, IBRAHIMPATNAM.

Er.arvindkundu@gmail.com