

Three Phase Four Leg VSI with Fuzzy Logic Control in Grid Connected Distribution System

Boda Balachandrudu

PG Scholar,

Dept EEE(EPS),

Anurag Group of Institutions,

Ghatkesar (M) Ranga Reddy (Dist.), Telagana, India.

Md Yaseen

Assistant Professor,

Dept of EEE,

Anurag Group of Institutions,

Ghatkesar (M) Ranga Reddy (Dist.), Telagana, India.

Abstract:

The non-linear loads such as power electronic equipments produce harmonics. The harmonic and reactive power cause poor power factor and distort the supply voltage at the common coupling point or customer service point. The international standards recommendation and requirements for harmonic control in electrical power systems imposed some harmonic limits [IEEE Standard,]. In order to solve this problem, it is necessary to research the alternative solution Active filters are widely employed in distribution system to suppress the harmonics and to compensate reactive power and neutral current. This paper proposes a fuzzy logic based three phase four wire four-leg shunt active power filter to suppress harmonic currents, compensate reactive power and neutral line current and balance the load currents. Modified instantaneous p-q theory is applied for calculating the compensating current. Fuzzy-logic based adaptive hysteresis band technique is applied for the current control to derive the switching signals for the voltage source inverter. The fuzzy adaptive hysteresis band current controller (HBCC) adjusts the hysteresis bandwidth according to modulation frequency, supply voltage, dc capacitor voltage and the slope of the reference compensator current wave. Computer simulations are carried out on a sample power system to demonstrate the suitability of the proposed technique

Keywords:

Active powers filter (APF), Harmonics, Power quality, Selective harmonic compensation.

I. INTRODUCTION:

The main objective of the power system is generation of electrical energy to transmit and distribute to the end-user. Many power system are internally connected into a network. If a fault exists in any one of the network, it should affect the whole power system. Transients, sagging, variations in voltage, harmonics are the some of disturbances affecting power system. The aim of this paper is to reduce the current harmonics. Basically, AC electrical power system mainly uses non-linear loads. For these types of loads, the load current and voltages are non-sinusoidal. So it is necessary to compensate the voltage and current harmonics. Non-linear loads are mainly used in adjustable-speed drives, switch mode power supply(SMPS), and un intertable power supply(UPS).

These types of loads will cause harmonic voltage drop across the network impedance, resulting in distorted voltage. Harmonics are one of the major concern in a power system. Harmonics are the non-integer multiples of the fundamental frequency. It is generated in a power system by means of non-linear loads. In order to reduce the harmonic distortion two types of filters can be used. 1) active filter 2) passive filter. A passive filter is composed of only passive elements such as inductor, capacitor and resistor. The passive filters are inexpensive. But they are ineffective due to the inability to adapt to network characteristic variations, which leads the use of active filters. An active filter is implemented when orders of harmonic currents are varying. It use active components such as MOSFET, IGBT-transistors etc.

Its structure may be either of the series or shunt type. Shunt active power filters are widely used for mitigating current harmonics. Series active filters are widely used for mitigating voltage harmonics. The drawbacks of series active filter are, they have to handle high load currents, which increase their current rating and increasing I^2R losses. It is mainly used at the load because non-linear loads inject current harmonics. It injects equal compensating currents, opposite in phase, to cancel harmonics and/or reactive currents of the non-linear load current at the point connection. More recently, voltage source inverter or current source inverter based active power filter is used. They have many advantages as compared to the previously used methods, which include potential size, weight and cost reduction, small size and light weight, low power losses, tracking of the power system frequency change, fast dynamic response to load changes and reduction of resonant problems.

In addition, APF can provide other conditioning functions such as reactive power control, load balancing and flicker mitigation. selective harmonic compensation can be used in to reduce the harmonics chosen by the designer. Many types of control schemes and controllers are available. The control algorithms are stationary reference frame theory, indirect current control method, Hysteresis current control, Band-reject filter method, and Synchronous-detection algorithm. Along with these, different soft computing techniques are used such as Artificial Neural Network (ANN), Genetic Algorithm (GA). Here linear current control scheme with PI and fuzzy logic controllers are discussed. This paper presents an alternate and effective method for controlling shunt active power filter. A fuzzy logic control based (FLCB) shunt active filter (SAF) capable of reducing harmonic distortion in power system proposed. The proposed method has advantage that the control block becomes simpler. The dc link fuzzy control has better dynamic behavior than conventional PI controller. The factors should be analyzed are total harmonic distortion (THD) and power factor(PF) improvement.

The shunt active filter control seems to be an attractive solution for harmonic current pollution problem. Here, harmonics reduction in the source current and power factor improvement are considered.

II.SHUNT ACTIVE POWER FILTER WITH NON-LINEAR LOAD:

Shunt active filter is used in the load side of the system. Because non-linear loads is to generate harmonics in the current waveform.

A. Basic Concept of Active Power Filter:

Fig.1 shows the configuration of active power filters with non-linear load. The basic operating principle of active power filter is that a non sinusoidal waveform at a bus can be corrected to sinusoidal by injecting current of proper magnitude and waveform.

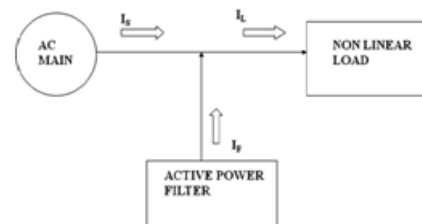

Fig1: Basic concept shunt active filter

The basic concept of APF is explained in fig

$$I_L = I_S + I_F \quad (1)$$

The load current having fundamental and harmonic content, and I_F is the harmonic compensating current.

$$I_L + I_H = I_S + I_H \quad (2)$$

Filter provide harmonic requirement of the load

$$I_L + I_H = I_S + I_H \quad (3)$$

$$I_L = I_S \quad (4)$$

Thus the supply current represents the fundamental waveform input output harmonics. Fig.2. shows the configuration of active shunt filter with non-linear load and the full bridge converter. This is almost widely used to eliminate current harmonics, reactive power compensation and balancing the unbalanced currents.

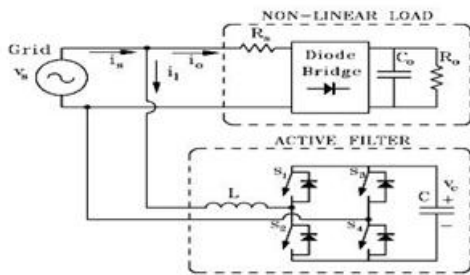

Fig2: Shunt APF with non-linear load and the full-bridge converter

B. Non-Linear Loads:

Non-linear loads are considered as the second category of loads. The application of sinusoidal voltage does not result in a sinusoidal flow applied sinusoidal voltage for non-linear devices. In this system the nonlinear load consists of a diode bridge, a series resistance (R_s), a load resistance (R_o) and a load capacitance (C_o), Induction motor load, and DC motor load.

1) CONTROL LOOPS:

This section reviews the, indirect current control method, based on the outer voltage loop and inner current loop.

A. Design of the Outer Voltage Loop:

For an indirect current control method, outer voltage loop is mainly used for capacitor voltage regulation. The capacitor is mainly used at the load side. For the design of outer voltage loop cut off frequency and phase margin is essential. Its value should be 2.5Hz and 56° based on the small signal model analysis.

B. Inner Current Loop:

For this linear current control scheme inner current loop is used for reference current tracking. Based on that reference is subtracted from the actual current, error current is produced. And then error current is compensated by PI controller.

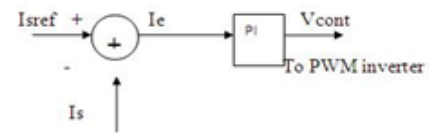

Fig3: Inner current loop

The control signal V_{cont} is the input of a pulse width-modulation. It will drives the power switches.

C. Reference Generator:

A reference generator is used to produce reference current signal by using the controller $H_1(s)$ and $H_2(s)$. Source current and reference current are subtracted. This operation is based on the closed loop Loop operation of notch filters.

The generalized integrators can be expressed as

$$H_1(s) = \frac{2\xi\omega_1\kappa_1s}{s^2 + 2\xi\omega_1s + \omega_1^2}$$

$$H_2(s) = \sum_{n=3}^h \frac{2\xi_n\omega_1\kappa_n s}{s^2 + 2\xi_n\omega_1s + (n\omega_1)^2}$$

The filter current is used in the inner current loop in order to track the load current harmonics. As an alternative the indirect method generates a sinusoidal reference signal by means of grid-voltage sensing.

IV. SAPF WITH PI CONTROLLER:

The main drawback of using repetitive current control is, there is no control action, to avoid the distortion from the grid voltage. In-order to overcome this drawback, it needs some additional algorithm.

A. Conventional Method:

The PI controller operation with shunt active filter is shown in figure.6. source voltage and source current values are given to the reference generator. It will produce I_{ref} and given to PI controller. Using PI controller error should be compensated.

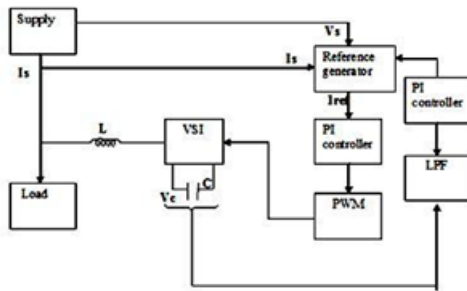

Fig4: Structure of PI controller

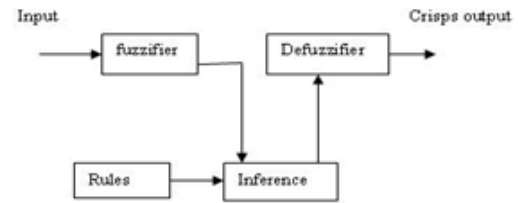

Fig5: Fuzzy controller block diagram

A low-pass filter is used to attenuate the frequencies higher than the cutoff frequency. It is sometimes called a high-cut filter, or treble cut filter when used in audio applications. A filter with low pass crossover frequency 10Hz is used. Based on the PWM signal the switches will be operated. And the signal is given to the Inverter Bridge.

[1] SAPF WITH FUZZY LOGIC CONTROLLER:

The Fuzzy Logic tool is a mathematical tool for dealing with uncertainty. It is important to observe that there is an intimate connection between Fuzziness and Complexity.

1. Fuzzy Logic Controller:

Fuzzy logic controller (FLC) are suitable for systems that are structurally difficult to model due to naturally existing non linear ties and other model complexities. This is because ,unlike a conventional controller such as PI controller, rigorous mathematical model is not required to design a good fuzzy controller. The database, consisting of membership functions. Basically membership value should lies between 0 to 1. The operations performed are fuzzification, interference mechanism and defuzzification. The interference mechanism uses a collection of linguistic rules to convert the input conditions into a fuzzified output. Finally defuzzification is used to convert the fuzzy outputs into required crisp signals.

B. Fuzzification:

Fuzzification is an important concept in the fuzzy logic theory. Fuzzification is the process where the crisp quantities are converted to fuzzy (crisp to fuzzy).By identifying some of the uncertainties present in the crisp values, we form the fuzzy values. The conversion of fuzzy values is represented by the membership functions.

C. Defuzzification:

Defuzzification means the fuzzy to crisp conversions .The fuzzy results generated cannot be used as such to the applications; hence it is necessary to convert the fuzzy quantities into crisp quantities for further processing.

D. FLC Design Methodology:

Design of fuzzy logic controller comprises the following steps.

1. Identifying the input signals to FLC.
2. Determining the number of membership function,
- and 3.Decide upon the type of membership function.

E. Membership Function:

The number of membership function determines the quality The number of membership function determines the quality of control which can be achieved using fuzzy logic controller(FLC). As the number of membership function increase, the quality of control improves at the cost of increased computational time and computer memory. Investigations are carried out considering seven membership function for each input and output signal.

e \ de	NL	NM	NS	ZE	PS	PM	PL
NL	NL	NL	NL	NL	NM	NS	ZE
NM	NL	NL	NL	NM	NS	ZE	PS
NS	NL	NL	NM	NS	ZE	PS	PM
ZE	NL	NM	NS	ZE	PS	PM	PL
PS	NM	NS	ZE	PS	PM	PL	PL
PM	NS	ZE	PS	PM	PL	PL	PL
PL	NL	NM	NS	ZE	PS	PM	PL

Table 1: Fuzzy rule Base

10. Fuzzy control scheme for APF:

In the fuzzy logic control algorithm for APF two inputs are required. The inputs are error and change in error. The two inputs were related by member functions. Basically forty nine rules are there. Based on the operation it will be used. The membership functions are expressed in negative large (NL), negative middle (NM), negative small(NS), zero(ZE), positive small(PS), positive middle(PM) and positive large(PL). Actual voltage is compared with the reference voltage, based on that error will be produced. It can be compensated by using fuzzy logic controller. Actual current is compared with the reference current, and error is compensated by fuzzy controller. Fuzzy sets support a flexible sense of membership functions.

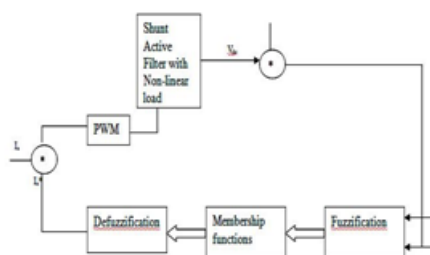

Fig6: Structure of the fuzzy for APF controller

A triangular membership function has the advantage of simplicity and easy implementation and is adopted in the application. Fuzzy inference is the process of formulating the mapping from a given input to an output using fuzzy logic. The centroid method of defuzzification is generally used, but disadvantage of this method is, it is computationally difficult for complex membership functions.

Here bisector method of defuzzification is used. The advantages of bisector method are, it is fast and generally produces good results.

VI. SIMULATION RESULTS:

The simulation is carried out with three phase four wire system with non-linear load. Here the diode rectifier is used as non-linear load. The comparisons are done for PI controller and FUZZY controller. The THD value is high because of pi controller in this circuit.

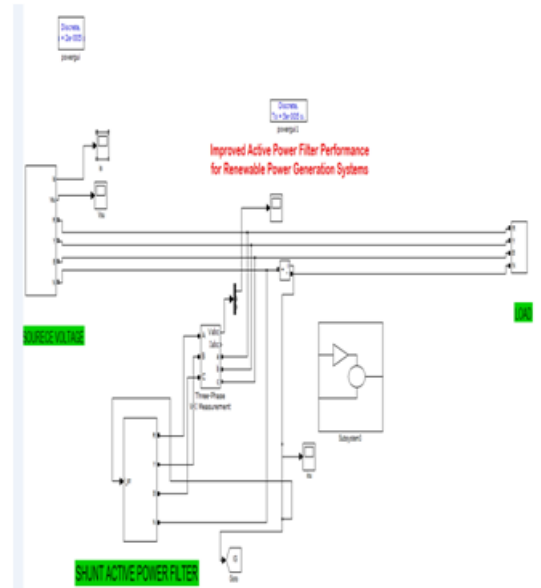

Subsystem

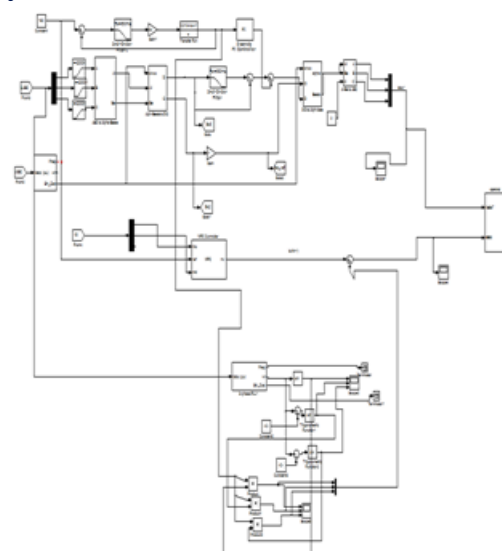

Source Voltage

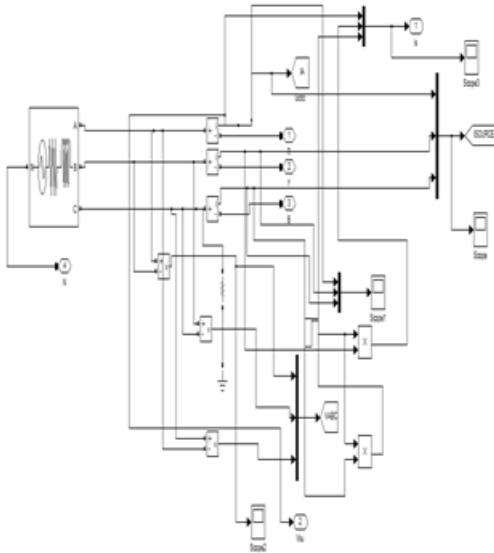

I_{ln}:

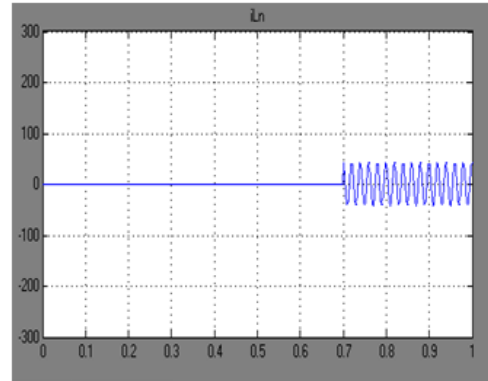

I_{sn} :

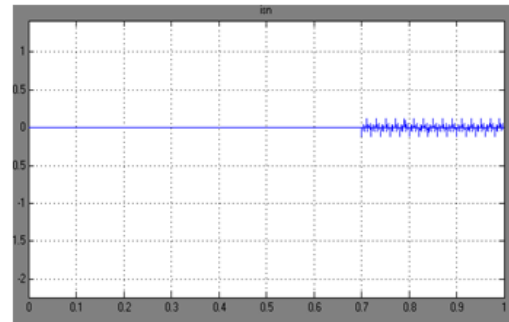

Shunt Active power filter

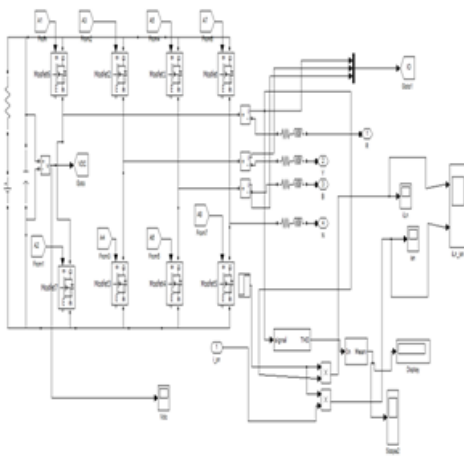

I_s:

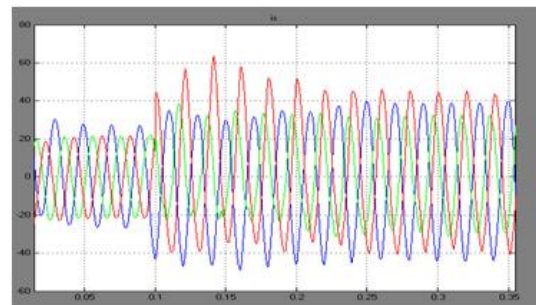

V_{su} :

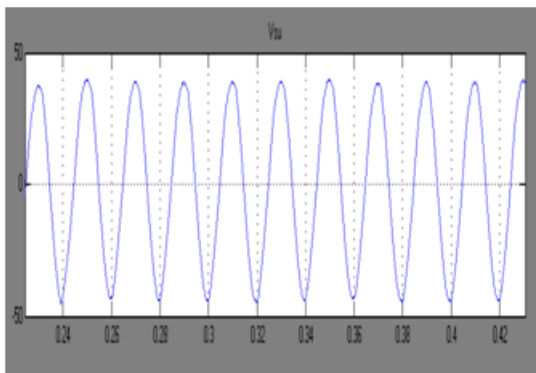

I_{ou} :

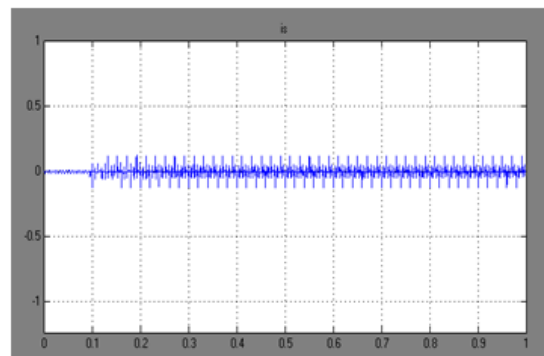

I_{lu} :

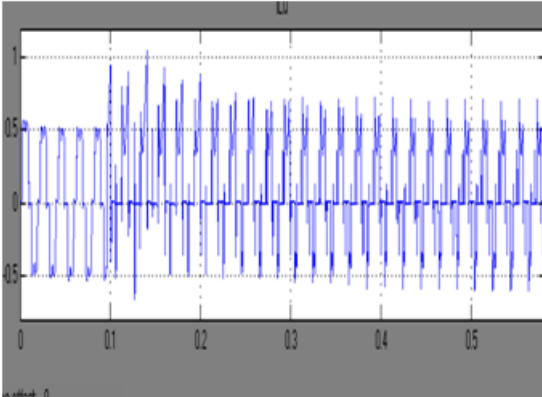

I_s

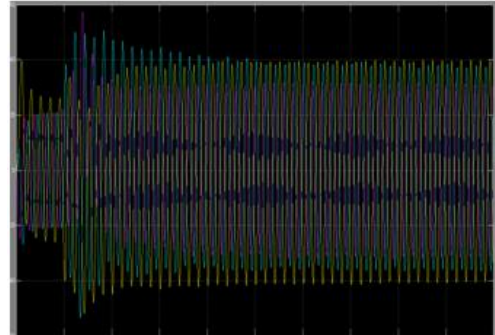

V_{su}

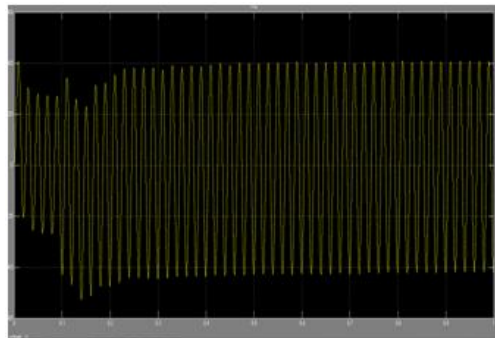

EXTENSION

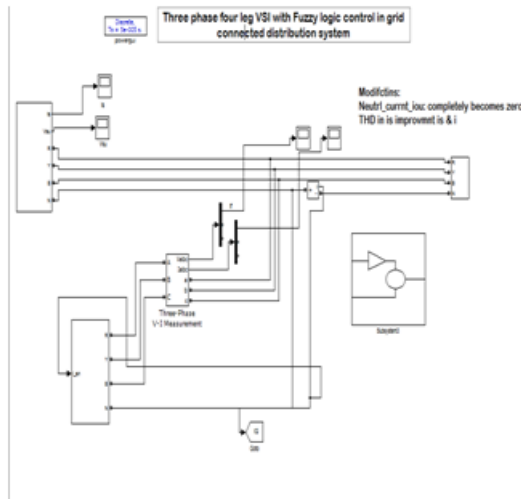

Modifications:

Neutral current I_{ou} : completely becomes zero

THD in is improvement is & i

With Fuzzy controller

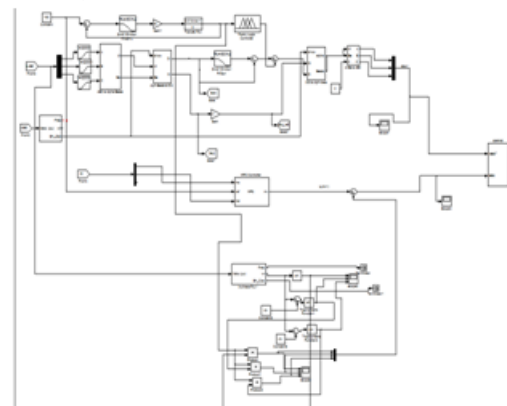

Output voltage

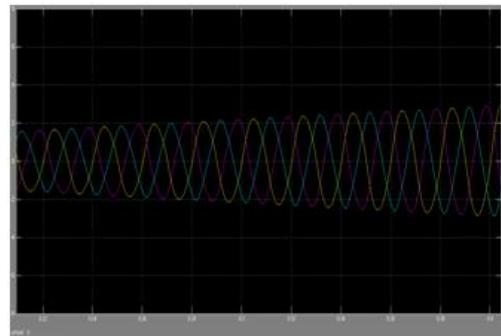

DC current :



CONCLUSION:

In the present paper two controllers are developed and verified for three phase four wire systems. Even though both of the Presented controllers are capable of compensating line current harmonics in 3 phase 4-wire systems, it can be seen that the Fuzzy logic controller has a better dynamic performance than the conventional PI controller. Hysteresis current control is used for quick response for generating gate pulses. Additionally, in contrast to the different control strategies; the d-q method is used for obtaining the reference currents in the system. This is due to the verity that the angle θ is considered directly from the main voltage which enables an operation which is frequency independent. As a result, this technique avoids large number of synchronization problems. It can also be seen that the DC voltage regulation system is a stable and steady-state error free system. Thus with fuzzy logic and the (d-q) approach, a shunt active filter can be developed. Simulation results are presented to validate the performance of the shunt active filter.

REFERENCES:

[1].H.Akagi —New trends in active filters for power conditioning, ||IEEE Trans. Ind. Appl., Vol. 32, No. 6, pp. 1312-1322, Nov./Dec.1996.

[2].F. Z. Peng, G. W. Ott Jr., D. J. Adams, —Harmonic and reactive power compensation based on the generalized instantaneous reactive power theory for three-phase four-wire systems|| IEEE Trans. Power Electron.,Vol. 13, No. 5, Nov. 1998.

[3].V. Soares, P. Verdelho, and G. Marques, —Active power filter control circuit based on the instantaneous active and reactive current id-iq method,||IEEE Power Electronics Specialists Conference, Vol. 2, pp

[4].M Suresh, A. K. Panda, S. S. Patnaik, and S. Yellasiri, —Comparison of two compensation control strategies for shunt active power filter in

three-phase four-wire system,|| in Proc. IEEE PES Innovative Smart Grid Technologies, pp. 1-6, 2011.

[5].Fang Zheng Peng and Akagi, (1990), —A New Approach to harmonic Compensation in Power Systems A combined System of Shunt Passive and Series Active Filters||, IEEE Transactions on Industrial Applications, Vol. 26, pp-6-11.

[6].Karuppanan P and Kamala kanta Mahapatra (2011), —PI with Fuzzy Logic Controller based Active Power Line Conditioners||- Asian Power Electronics, Vol. 5, pp-464468.

[7].Suresh Mikkili and Panda A.K. (2011), — PI and fuzzy logic controller based 3-phase 4-wire shunt active filter for mitigation of current harmonics with Id-Iq control strategy||, Power Electronics (JPE), Vol.11, pp-914-21.

[8]. Suresh Mikkili, Panda A.K. (2012), —Real-time Implementation of PI and Fuzzy logic controllers based shunt active filter control strategies for power quality improvement||, ELSEVEIR:Electrical Power and Energy System, Vol.43, pp-1114-1126.

[9].Saad S and Zellouma L. (2009), —Fuzzy logic controller for three-level shunt active filter compensating harmonics and reactive power||, Electronics Power System Research, Vol.79, pp-1337-1341.

[10]. S. K. Jain, P. Agrawal, and H. O. Gupta, —Fuzzy logic controlled shunt active power Filter for power quality improvement,|| Proceedings of Institute of Electrical Engineers, Electrical Power Applications,vol. 149, no. 5, 2002.

[11].Rodriguez P, Candela J.I, Luna A and Asiminoaei L. (2009), — Current harmonics cancellation in three-phase four-wire systems by using a four-branch star filtering Topology||, IEEE Transactions on Power Electronics, Vol. 24,pp-1939-50.

Author's Details:**Md. Yaseen**

Received his M.Tech (Power Systems & Automation) from GITAM University, Vishakapatnam in 2010 and B.Tech (EEE) from Adams Engineering College, Palvancha, Khammam Dist in 2008. Presently working as Assistant Professor (EEE Dept) in CVSR College of Engineering) Hyderabad. His area of Interest are Power Systems, Power Quality and Power Electronics.

**Boda Balachandrudu**

Received his B.tech from vishwa bharathi institute of technology and sciences rangareddy (dist) in 2014 and presently persuing m.tech (Electrical power systems) in Anurag group of institutions (autonomous) Ghatkeshar. His area of interests are power systems, power quality and power electronics.