

## **Analysis and Mitigation of Resonance Propagation in Grid-Connected and Islanding Microgrids by Using Fuzzy Logic**

**O.V.S.Prasad**

Department of Electrical and  
Electronics Engineering  
QIS Institute of Technology,  
Andhra Pradesh 523272, India.

**A.V.Suresh**

Department of Electrical and  
Electronics Engineering  
QIS Institute of Technology,  
Andhra Pradesh 523272, India.

**P.Venkateswarlu**

Department of Electrical and  
Electronics Engineering  
QIS Institute of Technology,  
Andhra Pradesh 523272, India.

### **Abstract**

*The impacts of voltage-controlled and current-controlled distributed generation (DG) units to microgrid resonance propagation are compared. It can be seen that a conventional voltage-controlled DG unit with an LC filter has a short-circuit feature at the selected harmonic frequencies, while a current-controlled DG unit presents an open-circuit characteristic. To mitigate the feeder harmonic distortions, a modified virtual impedance-based active damping method that consists of a virtual resistor and a virtual nonlinear capacitor is also proposed. The virtual capacitor eliminates the impacts of LCL filter grid-side inductor and the virtual resistor is interfaced to the receiving end of the feeder to provide active damping service. Due to different behaviors at harmonic frequencies, specific harmonic mitigation methods shall be developed for current controlled and voltage-controlled DG units, respectively. This paper also focuses on developing a voltage-controlled DG unit-based active harmonic damping method for grid-connected and islanding microgrid systems. Simulated results have been obtained from a single-phase low voltage microgrid. Here we are using fuzzy controller compared to other controller due to its accurate performance. The virtual resistance is principally answerable for microgrid resonance damping. The effectiveness of the proposed damping method is examined using each a single dg unit and multiple parallel dg units. Here fuzzy logic is used for controlling the simpered systems tool has proved that the combined system will at the same time inject maximum power and provide dynamic frequency support to the grid.*

*Index Terms— Active power filter, distributed power generation, droop control, grid-connected converter, microgrid, power quality, renewable energy system, resonance propagation, virtual impedance.*

### **I. INTRODUCTION**

The microgrid paradigm is emerging as an attractive way to future smart distribution grids, thanks to its capability to operate in both grid-connected and islanded modes. The dynamic islanding operations bring more flexibility on the integration of Distributed Generation (DG) units [1], and also provide a more reliable electricity service. On the other hand, during the islanded operations, the microgrid usually becomes much weaker and more sensitive to power quality disturbances. Thus, the harmonic distortion tends to be more apparent in an islanded microgrid.

Furthermore, since the use of LCL-filters [2] is gaining a wide acceptance in grid connected converters, the aggregated shunt capacitance for a number of LCL-filters may lead to harmonic resonance with the line inductance, and the consequent harmonic voltage amplification on a distribution feeder. Hence, stringent demands are being imposed on the ancillary services of inverter-interfaced DG units, such as the mitigation of circulating harmonic current in multiple DG units, harmonic voltage reduction and harmonic resonance damping.

**Cite this article as:** O.V.S.Prasad, A.V.Suresh & P.Venkateswarlu, "Analysis and Mitigation of Resonance Propagation in Grid-Connected and Islanding Microgrids by Using Fuzzy Logic", International Journal & Magazine of Engineering, Technology, Management and Research, Volume 5 Issue 2, 2018, Page 142-148.

To avoid the adoption of passive damping equipment, various types of active damping methods have been developed. Among them, the resistive active power filter (R-APF) is often considered as a promising way to realize better performance. Conventionally, the principle of R-APF is to emulate the behavior of passive damping resistors by applying a closed-loop current-controlled method (CCM) to power electronics converters [3].

In this control category, the R-APF can be simply modeled as a virtual harmonic resistor if it is viewed at the distribution system level. Additionally, a few modified R-APF concepts were also developed in the recent literature. In the discrete tuning method was proposed to adjust damping resistances at different harmonic orders. Accordingly, the R-APF essentially works as a nonlinear resistor. In the operation of multiple R-APFs was also considered, where an interesting droop control was designed to offer autonomous harmonic power sharing ability among parallel R-APFs [4].

The idea of Resistive-Active Power Filter (R-APF) is implemented based on a high-bandwidth current controller, where DG inverters are controlled to behave as resistors at harmonic frequencies, such that harmonic resonances and voltage distortions can be damped. To autonomously share harmonic currents, a droop relationship between the distorted power of a DG inverter and the controlled harmonic resistance is built.

However, it has been shown that only the output voltage of a DG unit is regulated in this method, whereas the voltage at the Point of Connection (PoC) tends to be undamped in the presence of grid-side inductance.

To alleviate the adverse effect of the grid-side inductance, a PoC voltage feed forward control scheme is developed recently. With a positive gain  $G$  in the PoC voltage feed forward loop, the harmonic impedance seen from the PoC [5] of a DG inverter can be scaled down by  $1/(1+G)$ . Nevertheless, the performance of this scheme is limited on the harmonic resonance damping

due to the absence of additional harmonic resistance. To achieve better operation of grid-connected and islanding microgrids, the paper considers a simple harmonic propagation model in which the microgrid is placed at the receiving end of the feeder.

To mitigate the feeder harmonic distortions, a modified virtual impedance-based active damping method that consists of a virtual resistor and a virtual nonlinear capacitor is also proposed. The virtual capacitor eliminates the impacts of *LCL* filter grid-side inductor and the virtual resistor is interfaced to the receiving end of the feeder to provide active damping service. Simulated results are provided to confirm the validity of the proposed method [6].

## II. SYSTEM MODELING

During the islanded operation, microgrid voltages usually becomes more sensitive to harmonic currents produced from the nonlinear loads, due to the limited power capacity of DG units and the low short-circuit ratio. Moreover, the presence of shunt capacitors tends to result in harmonic resonance and propagation throughout the microgrid. As a consequence, the mitigation of circulating harmonic current among all the DG units is needed to prevent overloading of some DG inverters, and meanwhile, proper resonance damping measures are also important to suppress harmonic voltage amplifications.

Fig. 1 illustrates an example of a low-voltage microgrid dominated by multiple inverter-interfaced DG units. A static switch is used to dynamically disconnect the microgrid from the upstream distribution system during abnormal conditions.

For the local and common loads, the diode rectifiers are used to denote the nonlinear loads, whereas the shunt capacitors represent the aggregated effect of capacitive loads and the capacitors in the *LCL*-filters of the grid-connected converters like battery chargers and active front-end rectifiers [7].

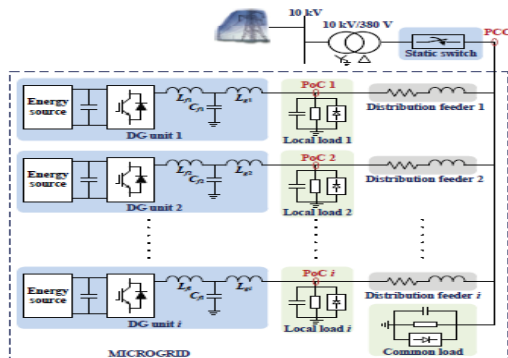

Fig.1. A sample low-voltage microgrid dominated with multiple inverter interfaced DG units.

For the sake of simplicity, this paper only adopts a simple microgrid configuration to demonstrate how the microgrid power quality is affected by resonance propagation. In addition, this paper also assumes that shunt capacitor banks and parasitic feeder capacitances are evenly distributed in the feeder. Fig. 2 illustrates the configuration of a single-phase microgrid system, where a few DG units are interconnected to the point of common coupling (PCC) through a long underground feeder [8].

Note that the static transfer switch (STS) controls the operation mode of the microgrid. When the main grid is disconnected from the microgrid, the PCC nonlinear loads shall be supplied by the standalone DG units.

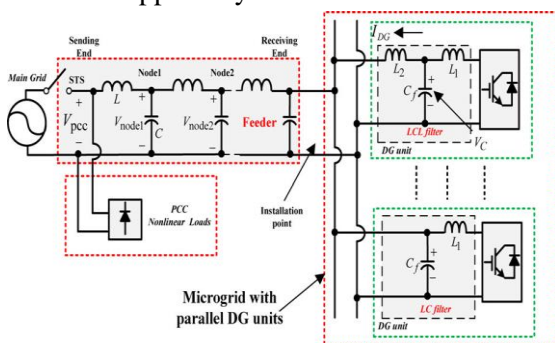

Fig.2. Simplified one-line diagram of a single-phase microgrid.

For a long feeder, as illustrated in Fig. 2, a lumped parameter model is not able to describe its resonance propagation characteristics. Alternatively, the distributed parameter model is discussed, where the voltage distortions at PCC induce a harmonic voltage standing

wave along the feeders. To make the discussion more straightforward, we assume that the microgrid in the feeder receiving end only consists of one DG interfacing converter. In the next section, the modeling of resonances in multiple DG-unit-based microgrid is discussed. The previous section focuses on the analysis of grid-tied DG units. For an islanding microgrid system, the VCM operation [9] of DG units is needed for direct voltage support.

To the best of the authors' knowledge, the quantitative analysis of islanding microgrid harmonic propagation is not available. By further utilizing the resonant controllers to avoid the derivative operation, the paper proposes a nonlinear virtual capacitor control method instead of the use of negative virtual inductor. This is because the impedance of a capacitor also has 90° lagging phase angle, which is the same as that in a negative inductor. However, for a capacitor with fix capacitance, its impedance magnitude is in inverse proportion to harmonic orders.

This feature is in contrast to the characteristics of a virtual inductor. With this modified outer loop controller, the DG unit fundamental voltage tracking and harmonic virtual impedance regulation can be realized separately. The detailed DG controller with the control of virtual nonlinear capacitor can be seen that the derivative operator in Fig. 3. In the revised controller, the harmonic voltage references associated with virtual resistor and virtual capacitor are only regulated by the harmonic resonant controllers [10].

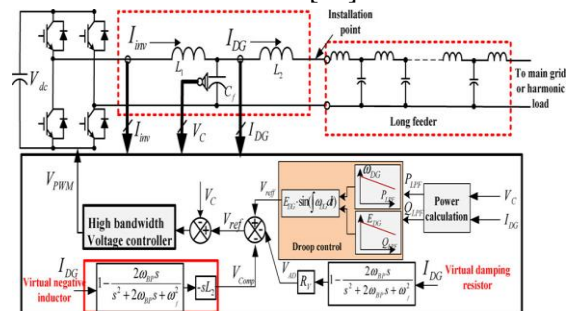

Fig. 3. Mitigation of distribution feeder harmonic propagation using virtual resistor and virtual negative inductor.

In this paper, a small proportional gain is selected to ensure that there is no noticeable coupling between the fundamental and the harmonic DG voltage tracking. With aforementioned efforts, the derivative operation is successfully avoided by using the proposed virtual nonlinear capacitor [11].

### III. SIMULATION RESULTS

Simulated results have been obtained from a single-phase low voltage microgrid. To emulate the behavior of six kilometers feeder with distributed parameters, a DG unit with an LCL filter is connected to PCC through a ladder network with six identical LC filter units. Each LC filter represents 1 km feeder.

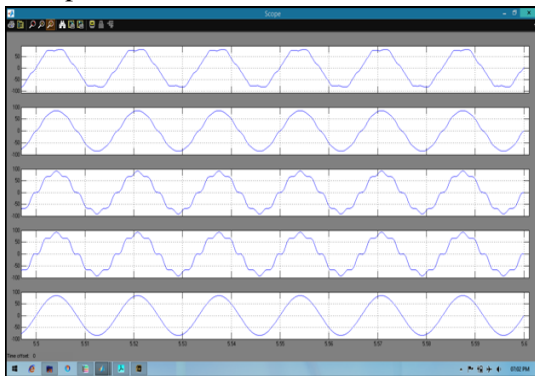

Fig 4 Harmonic voltage amplification during a single DG unit grid connected operation (without damping) (a) PCC voltage (b) node 1 voltage (c) node 3 voltage (d) node 5 voltage (e) DG unit filter capacitor voltage.

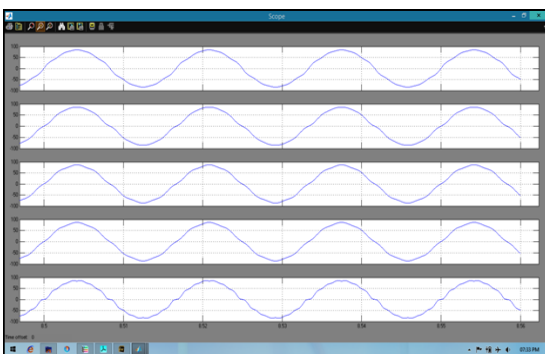

Fig 5 Harmonic voltage amplification during a single DG unit grid connected operation (with virtual nonlinear capacitor and resistor based active damping) (a) PCC voltage (b) node 1 voltage (c) node 3 voltage (d) node 5 voltage (e) DG unit filter capacitor voltage.

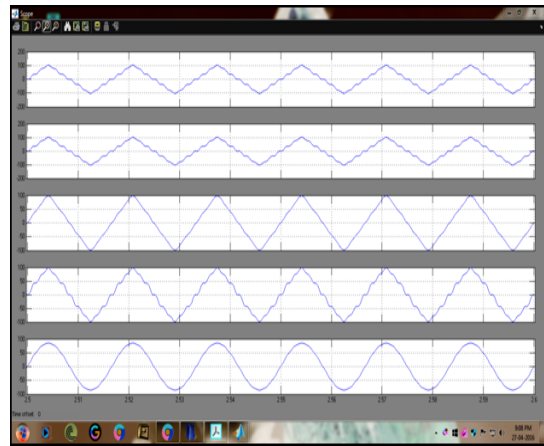

Fig 6 Harmonic voltage amplification during a single DG unit islanding operation (without damping) (a) PCC voltage (b) node 1 voltage (c) node 3 voltage (d) node 5 voltage (e) DG unit filter capacitor voltage.

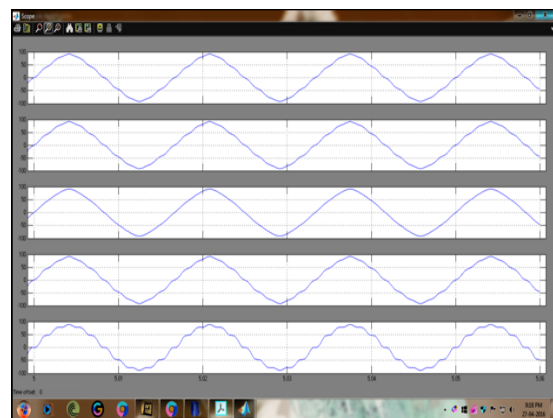
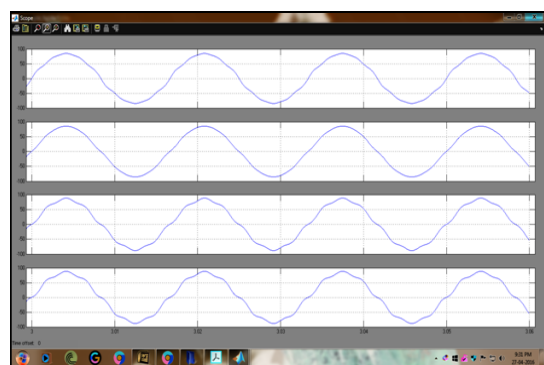
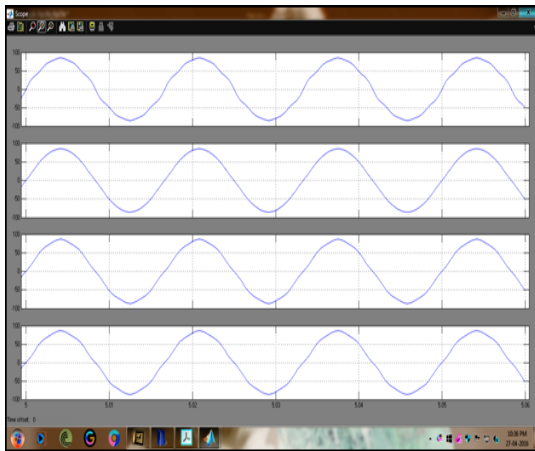

Fig 7 Harmonic voltage amplification during a single DG unit islanding operation (with virtual nonlinear capacitor and resistor based active damping) (a) PCC voltage (b) node 1 voltage (c) node 3 voltage (d) node 5 voltage (e) DG unit filter capacitor voltage.



(a)



(b)

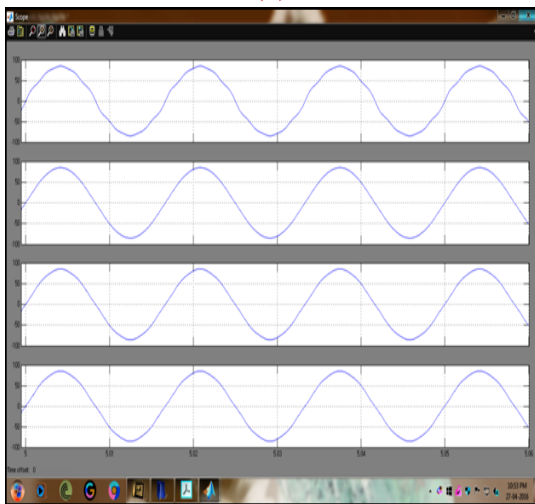

(c)

Fig 8 Harmonic voltage amplification along the feeders (grid-tied operation of two parallel DG units)

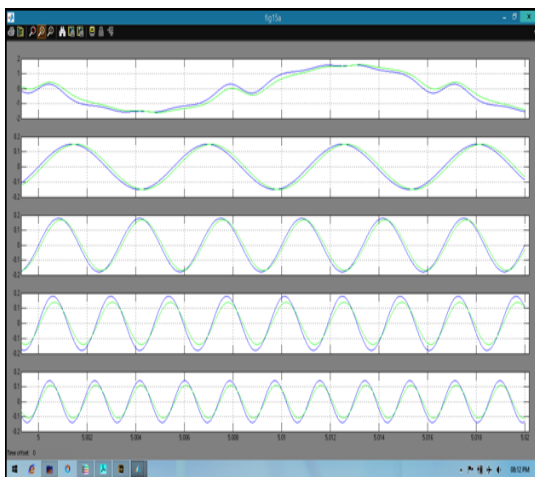

(a)

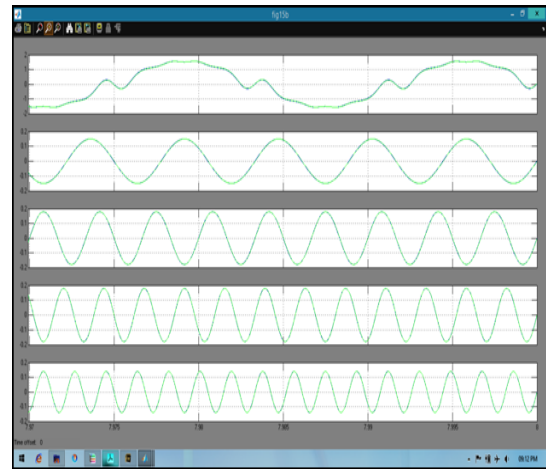

(b)

Fig 9 dg unit 1 and dg unit 2 line currents and their harmonic components (grid-tied operation of two parallel dg units)

Fuzzification is the process where the input crisp quantities are converted into fuzzy sets and also converts numeric (non fuzzy) input variables to linguistic (fuzzy) variables. The membership function is defined as errors and changes in error as Positive Small (PS), Positive Medium (PM), Positive Big (PB), Negative Small (NS), Negative Medium (NM) and Negative Big (NB).

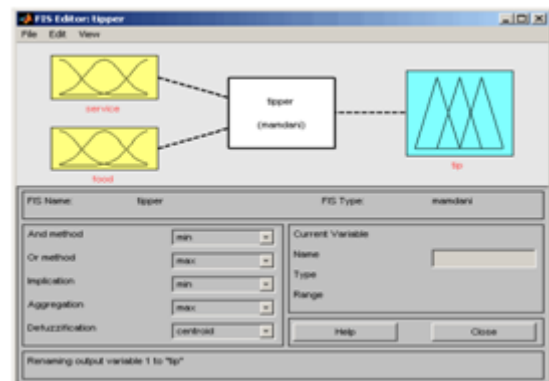

The FIS Editor GUI tool allows you to edit the highest level features of the fuzzy inference system, such as the number of input and output variables, the defuzzification method used, and so on. Refer to The FIS Editor for more information about how to use the GUIs associated with fuzzy. The FIS Editor is the high-level display for any fuzzy logic inference system. It allows you to call the various other editors to operate on the FIS. This interface allows convenient access to all other editors

with an emphasis on maximum flexibility for interaction with the fuzzy system.

Here fuzzy logic is used for controlling the simpered systems tool has proved that the combined system will at the same time inject maximum power and provide dynamic frequency support to the grid.

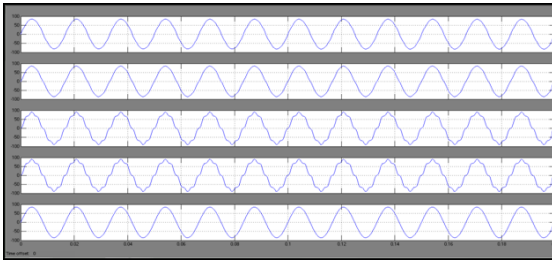

**Fig 10** Harmonic voltage amplification during a single DG unit grid connected operation (with virtual nonlinear capacitor and resistor based active damping by using fuzzy logic) (a) PCC voltage (b) node 1 voltage (c) node 3 voltage (d) node 5 voltage (e) DG unit filter capacitor voltage.

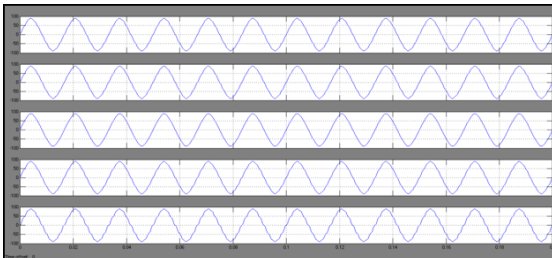

**Fig 11** Harmonic voltage amplification during a single DG unit islanding operation (with virtual nonlinear capacitor and resistor based active damping by using fuzzy logic) (a) PCC voltage (b) node 1 voltage (c) node 3 voltage (d) node 5 voltage (e) DG unit filter capacitor voltage.

#### IV. CONCLUSION

In this paper, a microgrid resonance propagation model is analyzed. To dynamically mitigate the resonance using DG units, an improved DG unit control scheme to uses the concept of virtual impedance is proposed. Particularly, the capacitive component of the proposed nonlinear virtual impedance is used to balance the impact of DG unit *LCL* filter grid-side inductor. The resistive component is accountable for active damping. With appropriately controlled DG equivalent harmonic

impedance at chosen harmonic frequencies, the proposed method can also reduce the harmonic circulating current among multiple DG units with mismatched output filter parameters. Comprehensive simulations are conduct to confirm the validity of the proposed method.

This paper concludes that a microgrid resonance propagation model is investigated by using fuzzy logic controller and to actively mitigate the resonance using DG units. An enhanced DG unit control scheme that uses the concept of virtual impedance by fuzzy. Here fuzzy controller is used compared to alternative controllers because of its accurate performance.

#### V. REFERENCES

- [1] H. Akagi, "Active harmonic filters," Proc. IEEE, vol. 93, no. 12, pp. 2128–2141, Dec. 2005.
- [2] H. Akagi, H. Fujita, and K. Wada, "A shunt active filter based on voltage detection for harmonic termination for radial power distribution system," IEEE Trans. Ind. Appl., vol. 35, no. 4, pp. 682–690, Jul./Aug. 1995.
- [3] K. Wada, H. Fujita, and H. Akagi, "Consideration of a shunt active filter based on voltage detection for installation on a long distribution feeder," IEEE Trans. Ind. Appl., vol. 38, no. 4, pp. 1123–1130, Jul./Aug. 2002.
- [4] P.-T. Cheng and T.-L. Lee, "Distributed active filter systems (DAFSs): A new approach to power system harmonics," IEEE Trans. Ind. Appl., vol. 42, no. 5, pp. 1301–1309, Sep./Oct. 2006.
- [5] T.-L. Lee and P.-T. Cheng, "Design of a newcooperative harmonic filtering strategy for distributed generation interface converters in an islanding network," IEEE Trans. Power Electron., vol. 42, no. 5, pp. 1301–1309, Sep. 2007.
- [6] T.-L. Lee, J.-C. Li, and P.-T. Cheng, "Discrete frequency-tuning active filter for power system



harmonics,” IEEE Trans. Power Electron., vol. 24, no. 5, pp. 1209–1217, Apr. 2009.

[7] T.-L. Lee and S.-H. Hu, “Discrete frequency-tuning active filter to suppress harmonic resonances of closed-loop distribution power system,” IEEE Trans. Power Electron., vol. 26, no. 1, pp. 137–148, Dec. 2010.

[8] N. Pogaku and T. C. Green, “Harmonic mitigation throughout a distribution system: A distributed-generator-based solution,” IEE Proc. Gener. Transmiss. Distrib., vol. 153, no. 3, pp. 350–358, May 2006.

[9] C. J. Gajanayake, D. M. Vilathgamuwa, P. C. Loh, R. Teodorescu, and F. Blaabjerg, “Z-source-inverter-based flexible distributed generation system solution for grid power quality improvement,” IEEE Trans. Energy Convers., vol. 24, pp. 695–704, Sep. 2009.

[10] Y.W. Li, D. M. Vilathgamuwa, and P. C. Loh, “Design, analysis and realtime testing of a controller for multibus microgrid system,” IEEE Trans. Power Electron., vol. 19, no. 5, pp. 1195–1204, Sep. 2004.

[11] Q.-C. Zhong and G. Weiss, “Synchronverters: Inverters that mimic synchronous generators,” IEEE Trans. Ind. Electron., vol. 58, no. 4, pp. 1259–1267, Apr. 2011.