

Adaptive Control Strategy for Low Voltage Ride through Capability Enhancement of Grid-Connected photovoltaic Power Plants

S.Sravanthi

Department of Electrical and
Electronics Engineering,
SSN Engineering College,
Ongole, Andhra Pradesh 523225,
India.

Dr.G V K Murthy

Department of Electrical and
Electronics Engineering,
SSN Engineering College,
Ongole, Andhra Pradesh 523225,
India.

B.Nagaraju

Department of Electrical and
Electronics Engineering,
SSN Engineering College,
Ongole, Andhra Pradesh 523225,
India.

Abstract:

This paper presents a novel application of continuous mixed -norm (CMPN) algorithm-based adaptive control strategy with the purpose of enhancing the low voltage ride through (LVRT) capability of grid-connected photovoltaic (PV) power plants. The PV arrays are connected to the point of common coupling (PCC) through a DC-DC boost converter, a DC-link capacitor, a grid side inverter, and a three-phase step up transformer. The DC-DC converter is used for a maximum power point tracking operation based on the fractional open circuit voltage method. The grid-side inverter is utilized to control the DC-link voltage and terminal voltage at the PCC through a vector control scheme. The CMPN algorithm-based adaptive proportional-integral (PI) controller is used to control the power electronic circuits due to its very fast convergence. The proposed algorithm updates the PI controller gains online without the need to fine tune or optimize. The effectiveness of the proposed control strategy is compared with that obtained using Taguchi approach based an optimal PI controller taking into account subjecting the system to symmetrical, unsymmetrical faults, and unsuccessful reclosing of circuit breakers due to the existence of permanent fault. The validity of adaptive control strategy is extensively verified by the simulation results, which are carried out using MATLAB/SIMULINK software. With the proposed adaptive-controlled PV power plants, the LVRT capability of such system can be improved.

Index Terms:

Adaptive control, low voltage ride through (LVRT), photovoltaic (PV) power systems, power system control, power system dynamic stability.

I. INTRODUCTION:

Being an important part of the modern energy infrastructure, distributed renewable energy (DRE) systems have been developed at a fast rate. For instance, in recent years, due to the continuous reduction of the photovoltaic (PV) module price and the strong global demand for environment-friendly energy conversion systems, the solar PV markets have been particularly booming. The capacity of solar PV was increased by 25% in 2014 (i.e., approximately 50 GW), bringing the global total to 227 GW. The annual market in 2015 was nearly 10 times the world's cumulative solar PV capacity of the last decade. In future, the DRE systems satisfy the requirements for the generation closer to the consumption points. However, with the fast development of distributed renewable power generations, stability and security have been attracting extensive attention. To cope with the challenges due to a high penetration level of PV systems, many research activities have been conducted recently to improve the integration of PV systems.

Cite this article as: S.Sravanthi, Dr.G V K Murthy & B.Nagaraju, "Adaptive Control Strategy for Low Voltage Ride through Capability Enhancement of Grid-Connected photovoltaic Power Plants", International Journal & Magazine of Engineering, Technology, Management and Research, Volume 5, Issue 2, 2018, Page 189-197.

In summary, it is expected that the grid-friendly PV systems should be multiple-functional. That is, for instance, reactive power control, maximum power point tracking (MPPT), fault islanding detection, harmonic compensation, and fault ride-through (FRT) operation are required for PV systems [1]. Actually, some PV power systems on today's market are already able to provide such services. Nevertheless, the PV systems should be more intelligent in consideration of grid stability, reliability, and fault protection at a high penetration level. A direct reflection of the increasing demands for PV systems is that many countries have revised or have been revising the national grid regulations, where the distributed generations are required to provide advanced grid fault-handling functionalities. According to the requirements, the PV systems should remain connected under grid faults, and also provide reactive power if demanded.

This is also referred to as the low-voltage ride-through (LVRT) capability. In extreme cases, i.e., the grid voltage dips to zero, and the disconnection from the grid is also not allowed within a predefined short-time interval (e.g., 150 ms), known as the zero-voltage ride-through (ZVRT) capability. Similarly, in zero-voltage conditions, the PV systems should also support the grid recovery by means of reactive current injection. Although the ZVRT operation can be taken as a special case of LVRT, a more dedicated control strategy should be performed during the FRT operation. Especially in single-phase grid-connected PV systems, when the fault occurs, the systems still inject sinusoidal reactive current to support the grid without grid information. Challenging issues for the ZVRT operation in the single-phase PV system include how to detect the grid voltage sags quickly, how to switch to the ZVRT operation mode with no grid information, and after the fault, how to resynchronize rapidly without triggering the over current protection. As aforementioned, the single-phase grid-connected PV system is required to operate in different modes accurately and rapidly in complicated situations. Adaptive filtering algorithms have been used to solve

several engineering problems in different applications such as signal processing, electronics engineering, audio, speech, and language applications. Recently, these algorithms were explored in electric power systems, since affine projection algorithm was utilized to adapt the PI controller parameters in a wind energy conversion system. In these algorithms, a compromise should be taken into consideration between the algorithm complexity and the convergence speed. Many comparisons have been made among the proposed CMPN algorithm and other adaptive filtering algorithms. The results have proven the high convergence speed of the CMPN algorithm over these algorithms for different applications. In this paper, a novel application of the CMPN algorithm-based adaptive control strategy is presented for enhancing the LVRT capability of grid-connected PV power plants. The DC-DC boost converter is used for a maximum power point tracking operation based on the fractional open circuit voltage method. The grid-side inverter is utilized to control the DC-link voltage and terminal voltage at the point of common coupling (PCC) through a vector control scheme. The CMPN algorithm-based adaptive PI controller is used to control the power electronic circuits due to its very fast convergence. The proposed algorithm updates the PI controller gains online without any need to fine tune or optimization. The PV power plant is connected to the IEEE 39-bus New England test system. The effectiveness of the proposed control strategy is compared with that obtained using Taguchi approach-based optimal PI controller taking into account subjecting the system to symmetrical, unsymmetrical faults, and unsuccessful reclosing of circuit breakers due to the existence of permanent fault [2].

II. SYSTEM MODELING:

In the low-voltage DRE system, the single-phase configuration is a more competitive solution. A generic control structure of the single-phase grid-connected PV system is shown in Figure 1, with an option of a DC-DC converter, which is used to boost up the PV panel voltage to a suitable level of the

following-stage DC-AC converter. The choice of single- or two-stage (i.e., without or with the DC-DC converter) is dependent on the control strategy, efficiency, cost, size and weight, etc. To guarantee a high-quality sinusoidal grid current, the inductor–capacitor–inductor (LCL) filter is adopted to improve the switching harmonic with lighter and smaller inductors.

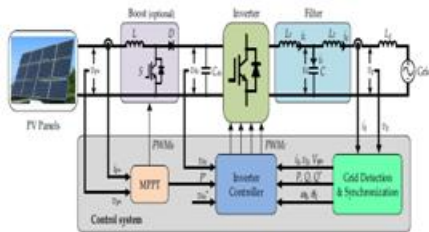

Fig.1. Generic control structure of the single-phase grid-connected photovoltaic (PV) system. Maximum power point tracking (MPPT).

In normal conditions, the PV system draws the maximum power from the PV arrays (i.e., in MPPT operation) and transfers it to the grid at unity power factor by using control strategy. The widely employed control strategy in single-phase inverters has two cascaded control loops. The inner loop is a current loop, in which the grid current quality can be guaranteed and the over current protection is also ensured. The outer loop is a voltage or power control loop, in which the voltage of the DC-side can be ensured and a reference of the inner current loop is calculated simultaneously in the outer loop. The PV arrays are connected to bus 18 of the test system through a DC-DC boost converter, a DC-link capacitor of 15 mF, a grid-side inverter, three-phase step up transformers, and double circuit transmission lines, as shown in Fig. 2. This system is considered a compact version of the original New England System and it is used for realistic responses study. The IEEE 39-bus system includes 39 buses out of which 19 are load buses. There are 10 generators in the system. Bus 31 at which generator 2 are reconnected is defined as the slack bus. The total load and generation of the system is 6098.1 and 6140.81 MW, respectively.

The load model is considered to be constant current and constant admittance load. In order to test the PV power plant with the IEEE 39-bus system, the PV power plant is connected to bus 18 [3].

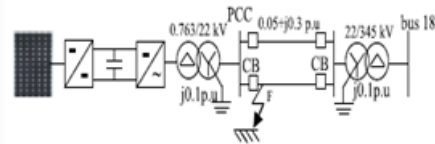

Fig.2. Grid-connected PV power plant Connection of PV power plant.

A DC-DC boost converter is used to control the output voltage of the PV plant in order to satisfy the maximum output power condition. This is done by controlling the duty cycle of insulated gate bipolar transistor (IGBT) switch of the converter, as indicated in Fig. 3. The fractional open circuit voltage method is applied to fulfill the maximum power condition.

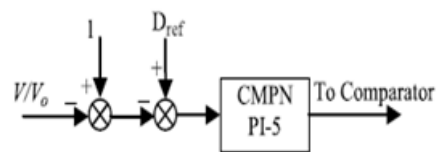

Fig. 3. Control of the DC-DC converter.

A CMPN-based adaptive PI controller is used for this purpose. The controller output signal is compared with a triangular carrier waveform signal of 4-kHz frequency to generate the firing pulses of IGBT switch. A two-level, three-phase, six IGBT switches inverter is proposed in this study. The grid-side inverter is utilized to control the DC-link voltage and terminal voltage at the PCC through a vector control scheme, as illustrated in Fig. 4. The CMPN algorithm-based adaptive PI controllers are developed for this purpose. A phase locked loop (PLL) is dedicated to detect the transformation angle from the three-phase voltages at the PCC.

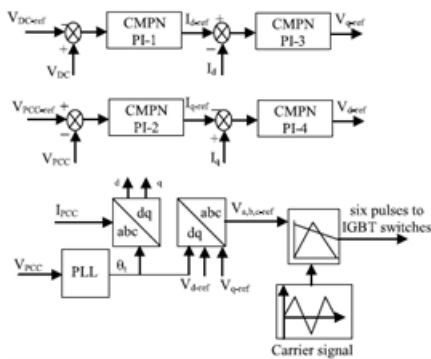

Fig. 4. Control block diagram of the grid-side inverter.

One family of the adaptive filtering algorithms is the mixed-norm adaptive filters that have various forms. In the least mean mixed-norm (LMMN) adaptive filter was presented, where it combined the least mean square (LMS) and the least mean fourth (LMF) algorithms. Moreover, a robust mixed-norm (RMN) algorithm was proposed and it combined the LMS algorithm with the least absolute deviation(LAD) algorithm. Then, a normalized RMN algorithm Once the grid phase-to-ground fault is detected by the grid synchronization, the photovoltaic (PV) system should switch to the grid fault operational mode with reactive power injection to support the grid recovery. In different countries, to fulfill various local conditions under national realities, the suitable grid code has been proposed. Figure 5 exemplifies the voltage profiles for the possible fault condition in some countries, where the PV systems should operate under the specific condition when the grid voltage is above the curves [6].

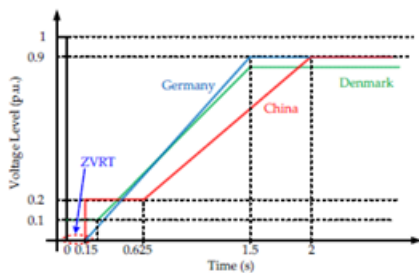

Fig. 5. Low-voltage (and zero-voltage) ride-through requirements for grid-connected systems in different countries.

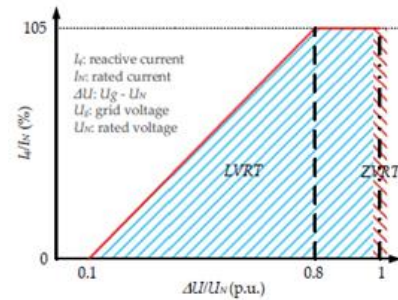

Fig. 6. Reactive current injection requirements under low-voltage ride-through/zero-voltage ride-through (LVRT/ZVRT) operations.

III. SIMULATION RESULTS:

The detailed model of a grid-connected PV power plant is presented. The model involves a complete switching model of the power electronic circuits with the proposed adaptive control strategy for obtaining realistic responses. The simulation results are performed using the powerful power system computer aided design (MATLAB/SIMULINK) software. In this scenario, a three-line to ground (3LG) temporary fault takes place at time $t=0.1$ s with duration of 0.1 s at fault point F. The CBs on the faulted lines are opened at $t=0.2$ s to clear fault. Then, the CBs are reclosed again at $t=1$ s. Successful reclosure of the CBs means reclosure under no fault condition.

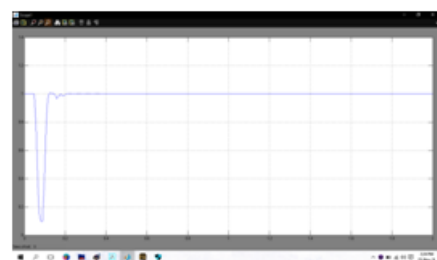

Fig:7(a)



Fig: 7(b)



Fig:7(c)

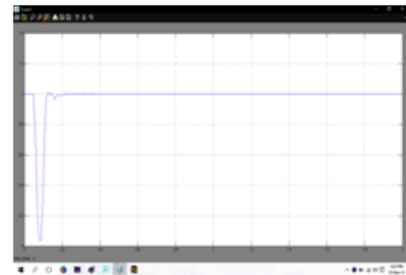

Fig:8(a)

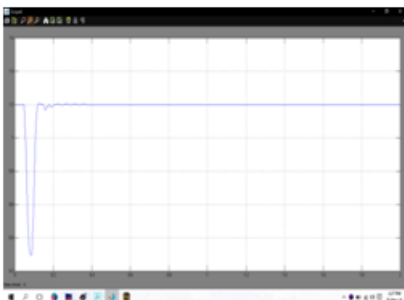

Fig:7(d)

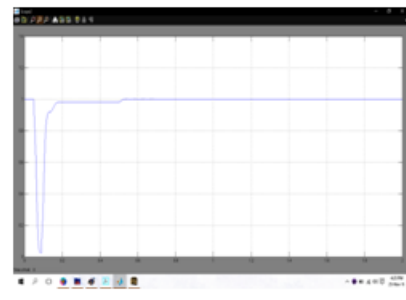

Fig:8(b)

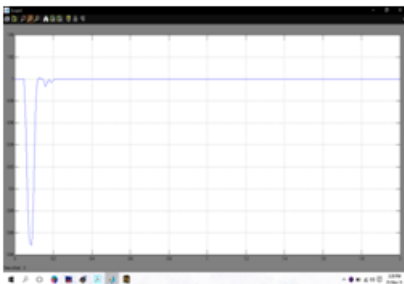

Fig:7(e)



Fig:8(c)

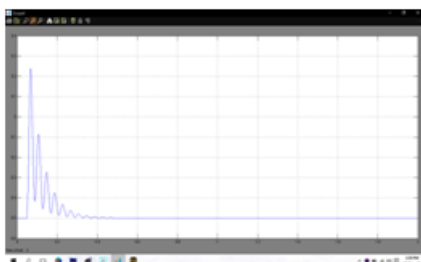

Fig:7(f)

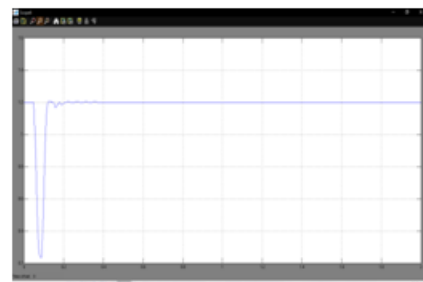

Fig:8(d)

Fig. 7. Responses of proposed system for 3LG temporary fault. (a) V_{pcc} . (b) Real power out of the PCC. (c) Reactive power out of the PCC. (d) V_{dc} . (e) Voltage at bus 18. (f) Inverter currents with the proposed controller.

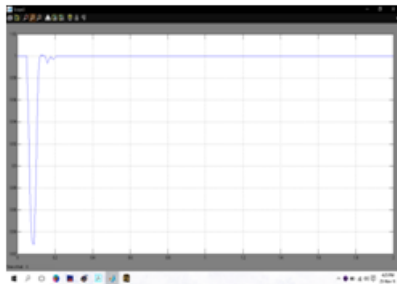

Fig:8(e)

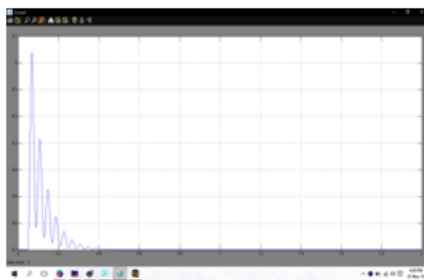

Fig:8(f)

Fig. 8. Responses of conventional system for 3LG temporary fault. (a) V_{pcc} . (b) Real power out of the PCC. (c) Reactive power out of the PCC. (d) V_{dc} . (e) Voltage at bus 18. (f) Inverter currents with the proposed controller.

The V_{pcc} drops immediately from the rated value (1 p.u) due to the effect of network disturbance and the grid side inverter delivers a good amount of reactive power that helps the V_{pcc} to return back to the rated value, as indicated in Fig. 7 & 8 (a). It is worth to note here that the V_{pcc} response using the CMPN-adaptive PI control strategy is better damped than that of using Taguchi approach-based an optimal PI control scheme, where it has lower maximum percentage undershoot, lower maximum percentage overshoot, lower settling time, and lower steady state error. Fig. 7 & 8 (b) points out the real power out of the PCC. It can be realized that the proposed controlled DC-DC converter controls efficiently the maximum output power of the PV plant at 1 p.u. The real power out of the PCC reaches final 0.96 p.u due to the converter, inverter, and transformer losses.

The reactive power out of the PCC, the V_{dc} , and voltage at bus 18 are shown in Fig. 7 & 8 (c)–(e), respectively. It can be noted that the responses using the proposed adaptive control strategy are very fast with minimum fluctuations. The online CMPN adaptive algorithm distinguishes a high speed convergence that updates the controller gains in an expedite way. Fig. 7 & 8 (f) indicates the direct axis and quadrature axis components of the inverter output currents (I_d and I_q). It can be realized that the proposed controller limits the rms inverter currents during the network disturbance to a value of 1.2 p.u, which lies in an acceptable range [4].

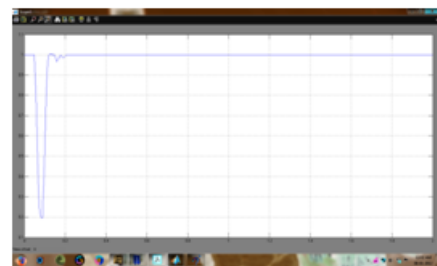

Fig:9(a)

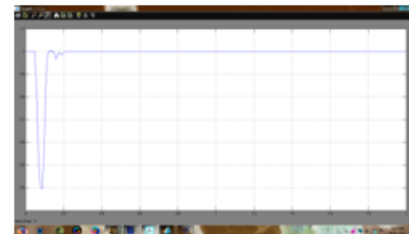

Fig:9(b)

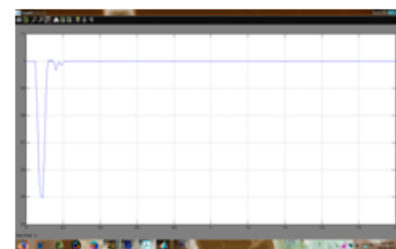

Fig:9(c)

Fig. 9. V_{pcc} response for unsymmetrical faults of proposed system. (a) 2LG fault. (b) LL fault. (c) 1LG fault.

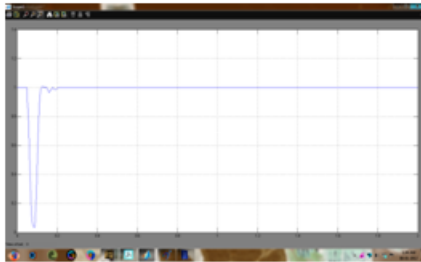

Fig:10(a)

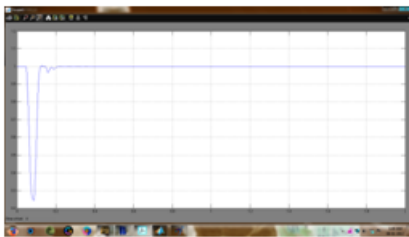

Fig:10(b)

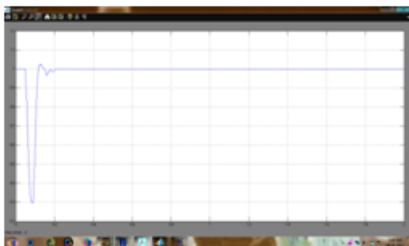

Fig:10(c)

Fig. 10. Vpcc response for unsymmetrical faults of conventional system. (a) 2LG fault. (b) LL fault. (c) 1LG fault.

Moreover, the proposed adaptive control strategy is extensively verified by subject the system to different types of unsymmetrical faults such as double-line to ground (2LG), line-to-line (LL), and single-line to ground (1LG) faults. Fig. 8&10(a)–(c) shows the Vpcc response under these types of faults. All the transient responses using the proposed control strategy are superior to that obtained using Taguchi approach-based an optimal PI control scheme. Therefore, the LVRT capability of the grid connected PV power plants can be further enhanced using the CMPN algorithm-based adaptive PI control strategy [8-9].

B. Unsuccessful Reclosure of CBs:

This scenario proposes a 3LG permanent fault occurring at point F in Fig. (a). The fault happens at $t=0.1s$ and its duration is assumed to be 6.9 s. The CBs on the faulted lines are opened at $t=0.2s$ and reclosed again at $t=1s$. Unfortunately, the CBs are closed on a permanent fault condition at this instant and this means unsuccessful reclosure of CBs. Therefore, the CBs are opened again at $t=1.1s$ and closed at $t=7.1s$, which means after the fault duration.

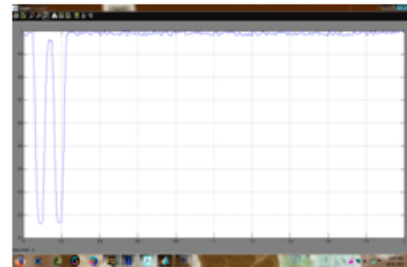

Fig:11(a)



Fig:11(b)

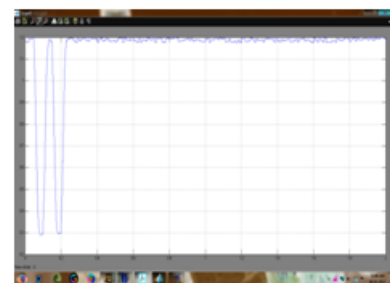

Fig:11(c)

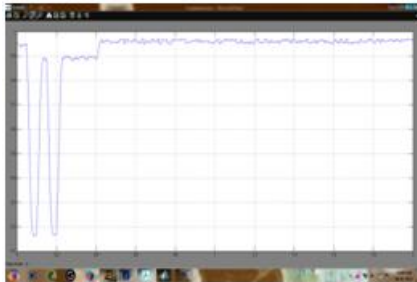

Fig:11(d)



Fig:12(d)

Fig. 11. Responses for 3LG permanent fault of conventional system. (a) V_{pcc} . (b) Real power out of the PCC. (c) Reactive power out of the PCC. (d) V_{dc} .

Fig. 12. Responses for 3LG permanent fault of conventional system. (a) V_{pcc} . (b) Real power out of the PCC. (c) Reactive power out of the PCC. (d) V_{dc} .

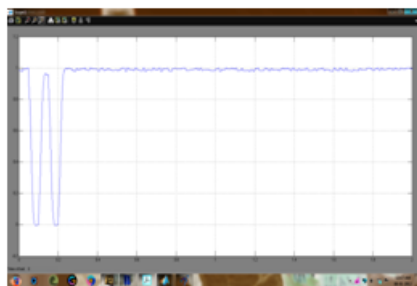

Fig:12(a)



Fig:12(b)



Fig:12(c)

Fig. 11& 12(a)–(d) indicates the responses of V_{pcc} , real and reactive powers out of the PCC, and V_{dc} , respectively. All responses have faster and better damped using the CMPN-based adaptive PI control strategy. Moreover, through permanent fault period, the V_{pcc} response lies in an acceptable range that agrees with the PV power plant grid codes. In addition, after permanent fault clearance and CBs final closure, the returns back with a fast response to its rated value. All system responses can return to their pre-fault values. Therefore, the proposed control strategy results in an enhancement of the LVRT capability of grid-connected PV power plants whatever under grid temporary or permanent fault condition. The high performance, accuracy, and superiority of the proposed CMPN algorithm-based adaptive PI controller to Taguchi-based an optimal PI controller are due to its proper design, its high convergence speed, and its flexibility to update the controller gains automatically online to minimize the error signals obtaining better results [5-7].

IV.CONCLUSION:

This project has introduced a novel application of the CMPN algorithm-based adaptive PI control strategy for enhancing the LVRT capability of grid-connected PV power plants. The proposed control strategy was applied to the DC-DC boost converter for a maximum power point tracking operation and also to the grid-

side inverter for controlling the V_{pcc} and V_{dc} . The CPN adaptive filtering algorithm was used to update the proportional and integral gains of the PI controller online without the need to fine tune or optimize. For realistic responses, the PV power plant was connected to the IEEE 39-bus New England test system. The simulation results have proven that the system responses using the CPN algorithm-based adaptive control strategy are faster, better damped, and superior to that obtained using Taguchi approach-based an optimal PI control scheme during the following cases:

- 1) subject the system to a symmetrical 3LG temporary fault;
- 2) subject the system to different unsymmetrical faults;
- 3) subject the system to a symmetrical 3LG permanent fault and unsuccessful reclosure of CBs.

It can be claimed from the simulation results that the LVRT capability of grid-connected PV power plants can be further enhanced using the proposed adaptive control strategy whatever under grid temporary or permanent fault condition. By this way, the PV power plants can contribute to the grid stability and reliability, which represents a greater challenge to the network operators. Moreover, the proposed algorithm can be also applied to other renewable energy systems for the same purpose.

V. REFERENCES:

- [1] PV Power Plants 2014 Industry Guide [Online]. Available: <http://www.pvresources.com>
- [2] D. L. Brooks and M. Patel, "Panel: Standards & interconnection requirements for wind and solar generation NERC integrating variable generation task force," in Proc. IEEE Power Eng. Soc. General Meeting 2011, Jul. 2011, pp. 1–3.
- [3] G. J. Kish, "Addressing future grid requirements for distributed energy resources," M.Sc. thesis, Dept. Elect. Comput. Eng., Univ. Toronto, Toronto, ON, Canada, 2011.
- [4] Y. Yang, F. Blaabjerg, and Z. Zou, "Benchmarking of grid fault modes in single-phase grid-connected photovoltaic systems," IEEE Trans. Ind. Applicat., vol. 49, no. 5, pp. 2167–2176, Sep./Oct. 2013.
- [5] Y. Yang, F. Blaabjerg, and H. Wang, "Low-voltage ride-through of single-phase transformerless photovoltaic inverters," IEEE Trans. Ind. Applicat., vol. 50, no. 3, pp. 1942–1952, May/Jun. 2014.
- [6] K. Kawabe and K. Tanaka, "Impact of dynamic behavior of photovoltaic power generation systems on short-term voltage stability," IEEE Trans. Power Syst., vol. 30, no. 6, pp. 3416–3424, Nov. 2015.
- [7] M. S. El Moursi, W. Xiao, and J. L. Kirtley, "Fault ride through capability for grid interfacing large scale PV power plants," IET Gener., Transm., Distrib., vol. 7, no. 5, pp. 1027–1036, 2013.
- [8] Y. Wu, C.-H. Chang, Y. Chen, C. Liu, and Y. Chang, "A current control strategy for three-phase PV power system with low-voltage ride-through," in Proc. IET Int. Conf. Advances on Power System Control, Operation, Management (APSCOM), 2012, pp. 1–6.
- [9] M. K. Hossain and M. H. Ali, "Low voltage ride through capability enhancement of grid connected PV system by SDBR," in Proc. IEEE PES T&D Conf. Expo., 2014, pp. 1–5.