

## Design of Automatic Number Plate Recognition System Using OCR for Vehicle Identification

**M.Kesab Chandrasen**

Assistant Professor,  
Department of ECE,  
A.I.E.T, Thagarapavalasa,  
Visakhapatnam.

**P.Sateesh Kumar**

Associate Professor,  
Department of ECE,  
A.I.E.T, Thagarapavalasa,  
Visakhapatnam.

**K.S.Guru Murthy**

Assistant Professor,  
Department of ECE,  
A.I.E.T, Thagarapavalasa,  
Visakhapatnam.

**V.Ravi Tejesvi**

Assistant Professor,  
Department of ECE,  
A.I.E.T, Thagarapavalasa,  
Visakhapatnam.

chandrasenmk@gmail.com

### Abstract:

Automatic Number Plate Recognition (ANPR) is an image processing technology which uses number (license) plate to identify the vehicle. The objective is to design an efficient automatic authorized vehicle identification system by using the vehicle number plate. The system is implemented on the entrance for security control of a highly restricted area like military zones or area around top government offices e.g. Parliament, Supreme Court etc. The developed system first detects the vehicle and then captures the vehicle image. Vehicle number plate region is extracted using the image segmentation in an image. Optical character recognition technique is used for the character recognition. The resulting data is then used to compare with the records on a database so as to come up with the specific information like the vehicle's owner, place of registration, address, etc. The system is implemented and simulated in Matlab, and its performance is tested on real image. It is observed from the experiment that the developed system successfully detects and recognizes the vehicle number plate on real images.

### Keywords:

Number Plate Recognition; vehicle identification; optical character recognition; Character Recognition.

### I. INTRODUCTION:

The Automatic Number Plate Recognition (ANPR) was invented in 1976 at the Police Scientific Development Branch in the UK. However, it gained much interest during the last decade along with the improvement of digital camera and the increase in computational capacity. It is simply the ability to automatically extract and recognition a vehicle number plate's characters from an image. In essence it consists of a camera or frame grabber that has the capability to grab an image, find the location of the number in the image and then extract the characters for character recognition tool to translate the pixels into numerically readable character.

ANPR can be used in many areas from speed enforcement and tool collection to management of parking lots, etc [1]. It can also be used to detect and prevent a wide range of criminal activities and for security control of a highly restricted areas like military zones or area around top government offices. The system is computationally inexpensive compare to the other ANPR systems [2][5]. Besides the robustness, the earlier methods use either feature based approached using edge detection or Hough transform which are computationally expensive or use artificial neural network which requires large training data [2][3][4]. The presented ANPR system is aimed to be light weighted so that it can be run real time and recognizes standard number plate under normal conditions. The ANPR system works in three steps, the first step is the detection and capturing a vehicle image, the second steps is the detection and extraction of number plate in an image. The third section use image segmentation technique to get individual character and optical character recognition (OCR) to recognize the individual character with the help of database stored for each and every alphanumeric character. The rest of the paper is organized as follows: section 2 will present the software and hardware models of the developed ANPR system. Section 3 will present the simulation results obtained using the developed ANPR system. Section 4 discusses the results briefly and finally section 5 will end the paper with conclusion and future works.

### II.SYSTEM MODEL:

The overall ANPR system can be subdivided into the software model and hardware model. The section will discuss the both models in detail.

#### A. Software Model:

The main and the most important portion of this system is the software model. The software model use series of image processing techniques which are implemented in MATLAB 7.0.1. The ANPR algorithm is broadly divided into three parts:

- Capture image
- Extract the plate from the image
- Recognize the numbers from the extracted plate

The first step is the capturing of an image using the USB camera connected to the PC. The images are captured in RGB format so it can be further process for the number plate extraction. The second step of the ANPR algorithm is the extraction of the number plate in an image. A yellow search algorithm is used to extract the likelihood ROI in an image. As the official number plate has yellow background with alphanumeric character written in black, it is easy to detect the plate area by searching for yellow pixels. The image is search for the yellow color pixels or some which are closer to yellow in value. If pixel value is of yellow color the pixel is set to 1, otherwise the pixel value is set to 0. The image obtained after the search algorithm is in black and white format. After identify the ROI, image is then filtered using two different filtering techniques.

The first technique involves removing of all white patches that are connected to any border and set their pixel value to 0. The second filtering technique use pixel count method to remove the small regions in an image other than the plate region. The number of consecutive white pixels is inspected and regions that contain number of white pixels less than the predefined threshold are set to 0. At this stage the image contains only the vehicle number plate. Smearing algorithm [x] is used next to extract the number plate in an image. The smearing algorithm is search for the first and last white pixels starting from top left corner of an image. The image is then cropped that only contain the vehicle number plate.

The third step of the developed ANRP algorithm uses Optical Character Recognition (OCR) algorithm to recognize the vehicle number. The resultant cropped image obtained after the second step is inverted i.e. all white pixels are converted to black and black pixels to white. Now the text is in white and the plate background is black. Before applying the OCR the individual lines in the text are separated using line separation process. The line separation adds the each pixels value in a row. If the resultant sum of row is zero that means no text pixel is present in a row and if the resultant sum of row is greater than zero that means the text is present in row. The first resultant sum greater than zero represents the start of the line and after this the first resultant sum equal to zero represents the end of the line.

The start and end values of the line is used to crop the first line in the text. The same process continues to separate the second line in the text. Once the lines in an extracted vehicle number plate are separated, the line separation process is now applied column wise so that individual character can be separated. The separated individual characters are then stored in separate variables. The OCR is now used to compare the each individual character against the complete alphanumeric database.

The OCR actually uses correlation method to match individual character and finally the number is identified and stored in string format in a variable. The string is then compared with the stored database for the vehicle authorization. The resultant signals are given according to the result of comparison. The complete detail of the software model is shown in figure 1.

## **B. Hardware Model:**

The hardware model consists of sensors to sense the presence of a vehicle, camera to capture the image, a motor with motor driver circuit to control the barrier on the entrance, PC on which algorithm is executed, and microcontroller for controlling the complete hardware of the ANPR system. As the vehicle enters and settles in the field of the sensor, the infrared sensor sense a vehicle and gives a signal to the PC through microcontroller 89C51 to capture the image of the vehicle.

The camera connected to the PC through USB port captures the image of a vehicle. The ANPR algorithm on a PC receives the image and performs the processing, which yields the vehicle number. This number is then compared to the authorized number to confirm its validity and finally provides signal to microcontroller to control the system hardware.

If the inputted plate contains the authorized number then the barrier on the entrance will be raised up using motor, green indication light will be switched on and 'Access Granted' will appear on the display, and if the inputted plate contains an unauthorized number then barrier will not be raised, red indication will be switched on and 'Access Denied' will appear on the display. The complete hardware model is shown in figure 2.

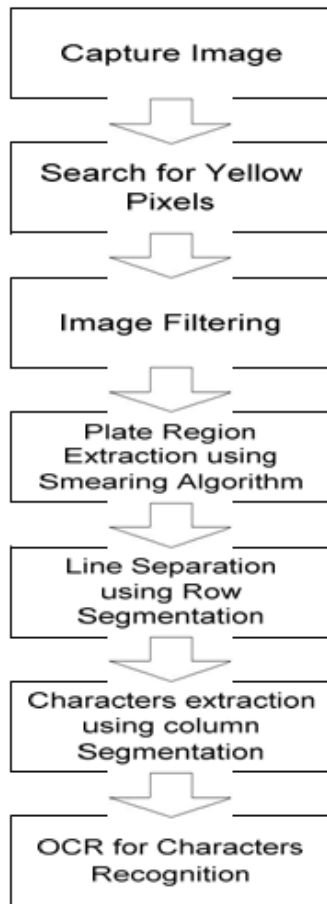

Figure 1: Steps of automatic number plate recognition software model

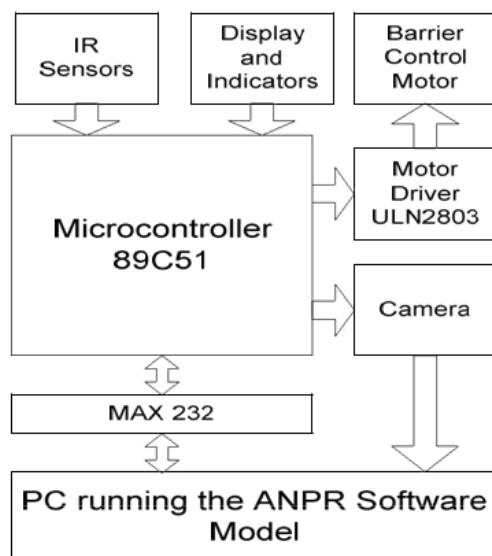

Figure 2 Hardware setup of ANPR system

### III.SIMULATION RESULTS:

This section presents the simulation results of the developed ANPR system. Firstly, the camera is interfaced using Matlab with the PC. The camera is attached using USB port. Different images of cars having different colors and structure types are taken and stored in PC. The different effects of the day lights are also considered during the processing. The images are in RGB format and the resolution is 800 x 600 pixels as shown in figure 3. After capturing the image the next step was the yellow search algorithm. Figure 4 shows the images after the executing the yellow search algorithm. The white region represents the yellow or color closer to the yellow. It can be observed that the yellow search algorithm successfully detect the ROI that only contain vehicle number plate.

The smearing algorithm used next to extract the vehicle number plate as shown in figure 5. Once the vehicle number plate is extracted, it is converted into the binary format. Figure 6 and figure 7 show the binary and inverted binary format respectively. The row and column segmentations methods are used next to extract the individual character in the vehicle number plate. The results of the row and column segmentation are shown in figure 8 and figure 9 respectively. Finally OCR is used for character recognition and each and every alphanumeric character is recognized as shown in figure 10.

### IV.DISCUSSION:

The system start works when the sensor detects the presence of car at the entrance. The micro-controller sends



Figure 3 Images taken using USB camera

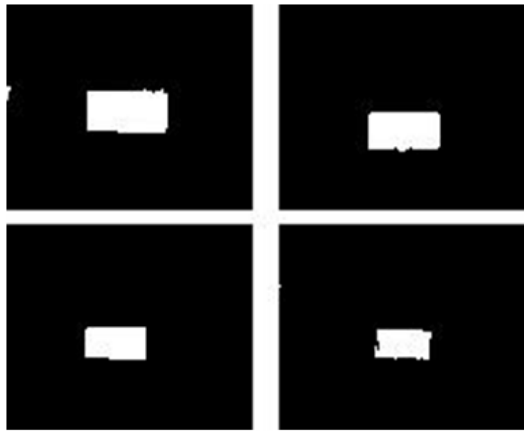

Figure 4 ROI detection using yellow search algorithm



Figure 5 Vehicle number plate extraction using smearing algorithm

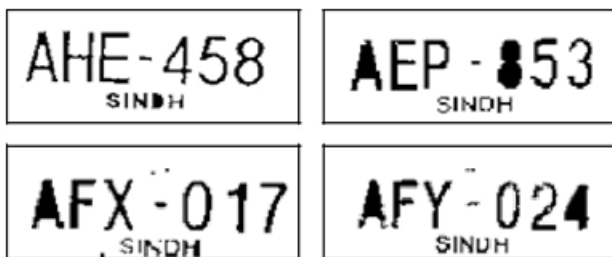

Figure 6 Binary image



Figure 7 Inverted binary image



Figure 8 Line separation using row segmentation

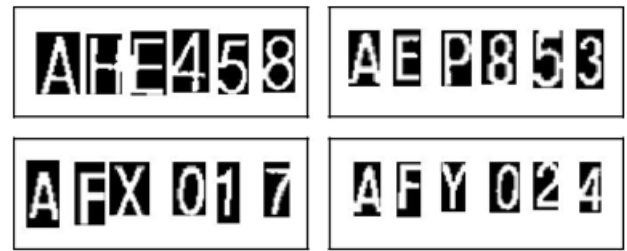

Figure 9 Character separation using column segmentation

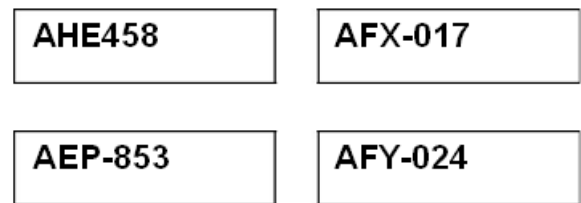

Figure 10 Recognize character using OCR

the signal to PC for capturing image using USB camera attached with the PC. The PC starts the ANPR algorithm and identifies the vehicle authorization. The ANPR algorithm is tested on large number of images with the resolution of 800 x 600 pixels. The results shows that the developed ANPR algorithm successfully detects the standard vehicle number plates in various day conditions and shows the higher detection and recognition rate. It can detect and recognize vehicle plates from various distances. The distance affects the size of the number plate in an image. Once the vehicle number plate is detected, the individual characters are recognized using the OCR algorithm. The OCR use correlation method for the character recognition and the probability of the recognition can also be calculated. The system is computationally inexpensive and can also be implemented for real time vehicle identification system.

## CONCLUSION AND FUTURE WORK:

In this paper, the automatic vehicle identification system using vehicle license plate is presented. The system use series of image processing techniques for identifying the vehicle from the database stored in the PC. The system is implemented in Matlab and it performance is tested on real images. The simulation results shows that the system robustly detect and recognize the vehicle using license plate against different lightening conditions and can be implemented on the entrance of a highly restricted areas. The implementation works quite well however, there is still room for improvement.

The camera used in this project is sensitive to vibration and fast changing targets due to the long shutter time. The system robustness and speed can be increase if high resolution camera is used. The OCR methods used in this project for the recognition is sensitive to misalignment and to different sizes, the affine transformation can be used to improve the OCR recognition from different size and angles. The statistical analysis can also be used to define the probability of detection and recognition of the vehicle number plate.

## REFERENCES:

- [1]Optasia Systems Pte Ltd, “The World Leader in License Plate Recognition Technology” Sourced from: [www.singaporegateway.com/optasia](http://www.singaporegateway.com/optasia), Accessed 22 November 2008.
- [2]. W. Hsieh, S. H. Yu, and Y. S. Chen. Morphology based license plate detection from complex scenes. 16th International Conference on Pattern Recognition (ICPR'02), pp. 79–179, 2002.
- [3]V. Kasmat, and S. Ganesan, “An efficient implementation of the Hough transform for detecting vehicle license plates using DSP’s,” IEEE International Conference on Real-Time Technology and Application Symposium, Chicago, USA, pp. 58-59, 2005.
- [4]S.H. Park, K.I. kim, K. Jung and H.J. Kim, “Locating car license plate using Neural Network,” Electronic Letters, Vol. 35, No. 17, pp. 1474 – 1477, 1999.
- [5]K.K. KIM, K.I., KIM, J.B. KIM, and H.J. KIM, “Learning-Based Approach for License Plate Recognition” Proceeding of IEEE Signal Processing Society Workshop, Vol. 2, pp.614-623, 2000.