

An Efficient and Easy Method to Track Patients during Natural Disaster

Sikinder Potla

Assistant Professor,

Department of Electronics & Communication Engineering,
Malla Reddy Institute of Engineering and Technology,
Dhulapally, Medchal, Secunderabad, Telangana 500014, India.

ABSTRACT

The aim of the project is to establish a communication between the patient and the hospital when there is a power extreme anger and no GSM or cell phone signals available during natural terrible events like cyclones, floods and winds storms. In the proposed system I used a remote watching/supervising and communication unit through which we can communicate with hospitals using a wireless sensor network using Zigbee rules of conduct. This network relays the data from one node to another node till the information reach the end node. There are two modes of starting the communication one is manual description of the patient's condition, another is a panic switch. In the first mode, the patient can describe his signs of sickness and condition with a described/explained description, so that the hospital's medical team can know what (steps taken to prevent trouble or injury) and medicines to be carried to the patient's place. Another mode is a panic switch. When the patient is in an emergency situation and there is no chance for him to describe his situation. Heart attack, in such conditions the patient will simply press a button, the device will automatically create a alert message along with the (how north or south you are/freedom to make decisions) and (how far east or west you are) information of the patient, and send it over to the hospital.

INTRODUCTION

Introduction of Embedded Systems

An embedded system can be defined as a computing device that does a specific focused job. Appliances such as the air conditioner, VCD player, DVD player, printer,

fax machine, mobile phone etc. are examples of embedded systems [1]. Each of these appliances will have a processor and special hardware to meet the specific requirement of the application along with the embedded software that is executed by the processor for meeting that specific requirement. The embedded software is also called "firm ware" [2]. The desktop/laptop computer is a general purpose computer.

We can use it for a variety of applications such as playing games, word processing, accounting, software development and so on.

Embedded systems do a very specific task; they cannot be programmed to do different things. Embedded systems have very limited resources, particularly the memory. Generally, they do not have secondary storage devices such as the CDROM or the floppy disk. Embedded systems have to work against some deadlines. A specific job has to be completed within a specific time. In some embedded systems, called real time systems, the deadlines are stringent. Missing a deadline may cause a catastrophe loss of life or damage to property. Embedded systems are constrained for power.

As many embedded systems operate through a battery, the power consumption has to be very low. Some embedded systems have to operate in extreme environmental conditions such as very high temperatures and humidity [3].

Cite this article as: Sikinder Potla, "An Efficient and Easy Method to Track Patients during Natural Disaster", International Journal & Magazine of Engineering, Technology, Management and Research, Volume 5 Issue 1, 2018, Page 109-114.

Overview of Embedded System Architecture

Every embedded system consists of custom built hardware built around a Central Processing Unit (CPU) [4]. This hardware also contains memory chips onto which the software is loaded. The software residing on the memory chip is also called the ‘firmware’. The embedded system architecture can be represented as a layered architecture as shown in figure. The operating system runs above the hardware, and the application software runs above the operating system.

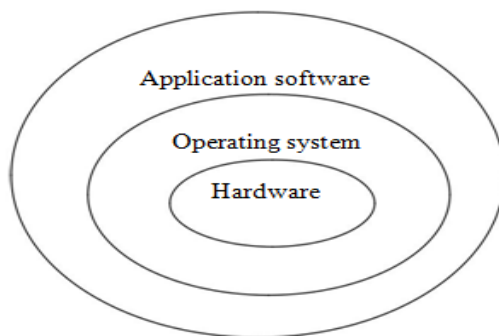

Layered Architecture of Embedded Systems

Need for Embedded Systems

The uses of embedded systems are virtually limitless, because every day new products are introduced to the market that utilizes embedded computers in novel ways. In recent years, hardware such as microprocessors, microcontrollers, and FPGA [4] chips have become much cheaper. Producing a custom made chip to handle a particular task or set of tasks costs far more time and money. Many embedded computers even come with extensive libraries, so that “writing your own software” [5] becomes a very trivial task indeed. From an implementation view point, there is a major difference between a computer and an embedded system. Embedded systems are often required to provide a real time response. The main elements that make embedded systems unique are reliability and ease in debugging.

EXISTING METHOD

The existing method is a conventional process in which patients use to communicate with doctors by using landlines, mobile phones, internet and smart android applications like whatsapp, vibe etc.

PROPOSED SYSTEM

This system is a remote monitoring and communication unit through which we can communicate with hospitals using a wireless sensor network using Zigbee protocol [6]. Zigbee protocol works on 2.4Ghz and it is a peer to peer communication network. This networks relays the data from one node to another node till the information reach the end node.

KEY COMPONENTS

- Operating system
- GPS
- Zigbee
- LCD
- Personal computer

WORKING:

This project is based on wireless communication using zigbee technology where the Zigbee protocol works on 2.4Ghz and a peer to peer communication network. This networks relays the data from one node to another node till the information reach the end node. Zigbee transmitter, GPS tracker, heart beat and temperature sensor are connected to raspberry pi. We track the patient’s location with GPS tracker and monitor patient’s heart beat and temperature continuously by using heart beat sensor and temperature sensor [7].

In this project there are three modes.

1. When the power shortage occurs, the transmitter automatically send heart beat, temperature readings and location (longitude, latitude) to the nearby hospital and also LCD displays “ POWER OUTAGE”.
2. Whenever we want, we can type patient’s condition using keyboard and send to doctor with location so that doctor can understand patient’s condition clearly.
3. When the patient is in critical condition, we can press the panic switch so that the “EMERGENCY” message will be sent to nearby hospital with location, heart beat and temperature readings, so that the hospital may take emergency action to save the patient [8].

The battery is connected to raspberry pi. When the power cut happens, the equipment works by battery so that the system can monitor patient's condition without interruption. This battery lifetime will be up to 2-3 hours.

Mainly the block diagram of the project consists of Raspberry Pi, Liquid Crystal Display (LCD), Zigbee, panic switch, buzzer, PC, GPS are used Which are shown in following figures

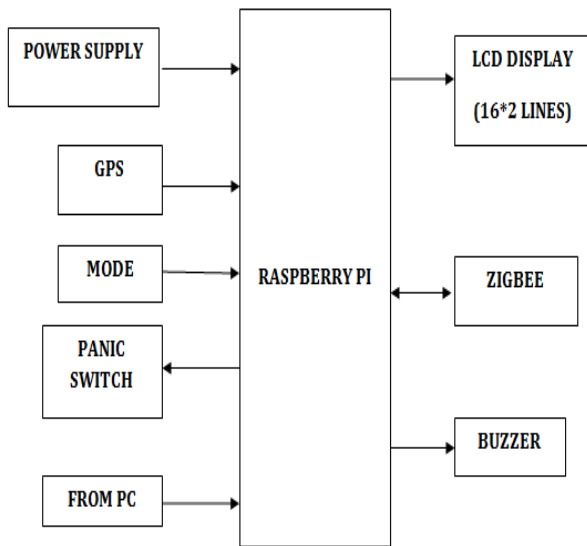

Block Diagram of the Transmitter

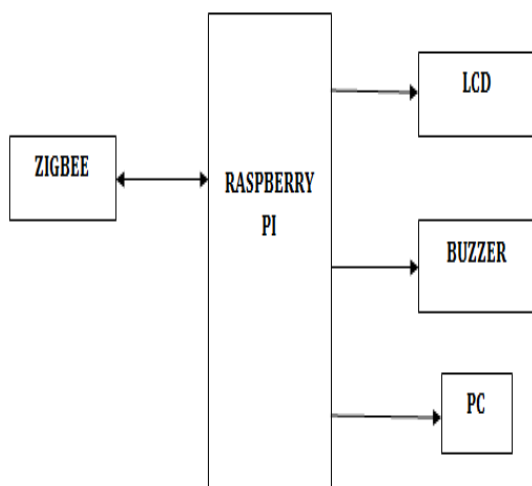

Block Diagram of the Receiver

HARDWARE IMPLEMENTATION

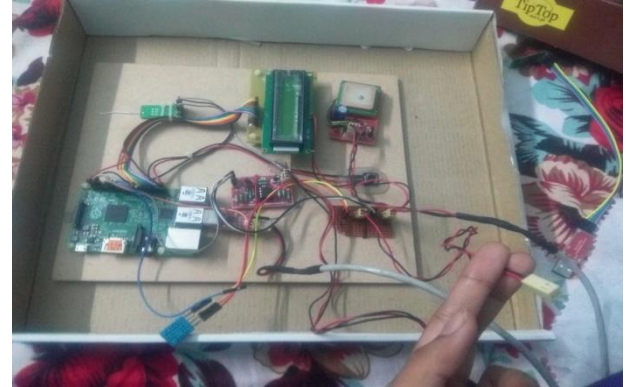

Hardware Implementation

RASPERRY PI



Raspberry Pi

Raspberry Pi is used from controlling hardware with Python, to using it as a media centre, or building games in Scratch [9]. The beauty of the Raspberry Pi is that it's just a very tiny general-purpose computer (which may be a little slower than you're used to for some desktop applications, but much better at some other stuff than a regular PC), so you can do anything you could do on a regular computer with it. In addition, the Raspberry Pi has powerful multimedia and 3D graphics capabilities, so it has the potential to be used as a games platform, and we very much hope to see people starting to write games for it.

Raspberry Pi board is a miniature marvel, packing considerable computing power into a footprint no larger than a credit card. It's capable of some amazing things, but there are a few things you're going to need to know before you plunge head-first into the bramble patch.

ZIGBEE

ZigBee is a low-cost, low-power, wireless mesh networking proprietary standard. The low cost allows the technology to be widely deployed in wireless control and monitoring applications, the low power-usage allows longer life with smaller batteries, and the mesh networking provides high reliability and larger range.

The ZigBee Alliance, the standards body that defines ZigBee, also publishes application profiles that allow multiple OEM vendors to create interoperable products. The current list of application profiles either published or in the works are:

- Home Automation
- ZigBee Smart Energy
- Commercial Building Automation
- Telecommunication Applications
- Personal, Home, and Hospital Care
- Toys

ZigBee operates in the industrial, scientific and medical (ISM) radio bands; 868 MHz in Europe, 915 MHz in the USA and Australia, and 2.4 GHz in most jurisdictions worldwide. The technology is intended to be simpler and less expensive than other WPANs such as Bluetooth. ZigBee chip vendors typically sell integrated radios and microcontrollers with between 60K and 128K flash memory, such as the Jennic JN5148, the Freescale MC13213, the Ember EM250, the Texas Instruments CC2430 and the Atmel ATmega128RFA1. Radios are also available stand-alone to be used with any processor or microcontroller. Generally, the chip vendors also offer the ZigBee software stack, although independent ones are also available [8].

Because ZigBee can activate (go from sleep to active mode) in 15 msec or less, the latency can be very low and devices can be very responsive — particularly compared to Bluetooth wake-up delays, which are typically around three seconds. Because ZigBees can sleep most of the time, average power consumption can be very low, resulting in long battery life.

GPS:

The Global Positioning System (GPS) is a satellite-based navigation system that sends and receives radio signals. A GPS receiver acquires these signals and provides you with information. Using GPS technology [9], you can determine location, velocity, and time, 24 hours a day, in any weather conditions anywhere in the world—for free.

- Know precisely how far you have run and at what pace while tracking your path so you can find your way home.
- Pinpoint the perfect fishing spot on the water and easily relocate it.
- Get the closest location of your favorite restaurant when you are out-of-town.
- Find the nearest airport or identify the type of airspace in which you are flying

RESULTS

The At- Home Medical equipment is set and the heart beat and temperature sensors are connected to the patient’s finger. The set up will be continuously running and displays “Health Care Alert Natural Disaster” on LCD display.



At- Home Health Monitoring System



At- Home Health Monitoring System Result on LCD

If the patient wants to send any message to hospital then he can send it manually. The patient sending messages “HELP” to the hospital. We can describe patient’s condition by typing manually.



Manual Description of Patient

The received message at the receiver end will be displayed as shown in fig 5.6. The data consist of Longitude, Latitude, Heartbeat, Temperature and the message typed by the person. The receiver is connected to the system and which contains X-CTU software. The output will be displayed in X-CTU terminal.

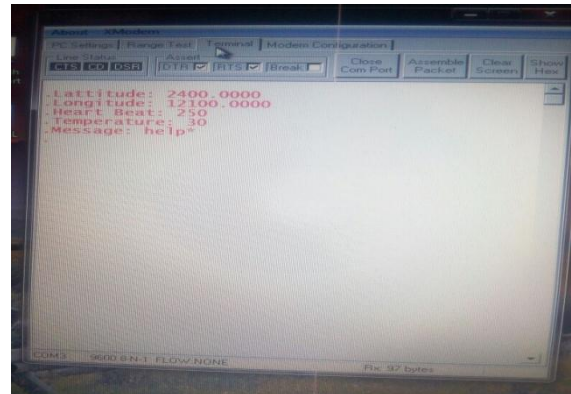

Data at the Receiver End



Sending Data through ZIGBEE

If the power outage will occur then the system automatically send patient’s last details before power outage to the hospital with a message of “EMERGENCY”. If the patient is in critical condition and not in a stage to describe his condition then he can directly press the “PANIC SWITCH” which will also send the same message to the hospital so that doctor can help the patient immediately.

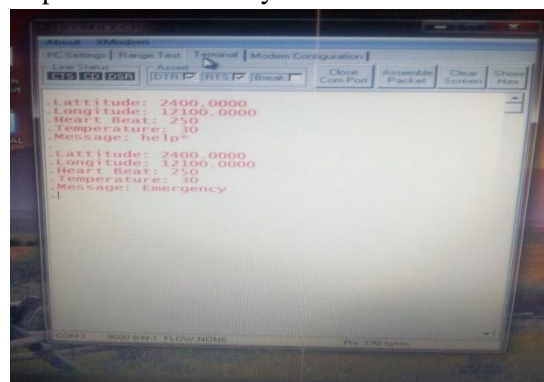

Data at the Receiver When Panic Switch is Used or Power outage occurs

The message received by the receiver consists of the manual description of patient, Heartbeat, Temperature and the location of the patient. The Acknowledgement will be displayed on LCD.



Acknowledgement of Sent Message

CONCLUSION AND FUTURE SCOPE

The project “A Wireless Tracking System for At-Home Medical Equipment during Natural Disasters” has been successfully designed and tested.

Integration of all the hardware components and presence of every module has been reasoned out and placed carefully thus contributing to the best working of the unit. Secondly, using highly advanced operating system and with the help of growing technology the project has been successfully implemented. With the help of Zigbee technology, the communication with doctor becomes possible. The implementation of panic switch efficiently conveying the emergency condition of patient with needed information. The project provides the communication path between patient and doctor in critical conditions successfully.

The future scope is to implement this project using Wi-Fi ad hoc network and can be established for wide range of area.

REFERENCES

- [1] Guojin Li, Jing, Application of the medical care system based on ZigBee technology, Electrical & Electronics Engineering (EEESYM), 2012 IEEE Symposium
- [2] Cristian Rotariu, Vasile Manta, Haritan Costin, Wireless remote monitoring system for patients with cardiac pacemakers, Electrical and Power Engineering (EPE), 2012 International Conference and Exposition
- [3] Mladen A. Poluta, A Medical Device Regulatory Framework - Case Study: South Africa, Engineering in Medicine and Biology Society, 2006. EMBS '06. 28th Annual International Conference of the IEEE
- [4] Dayu He, The ZigBee Wireless Sensor Network in medical care applications Computer, Mechatronics, Control and Electronic Engineering (CMCE), 2010 International Conference
- [5] J. Nicholl, J. West, S. Goodacre, and J. Turner, The relationship between distance to hospital and patient mortality in emergencies: an observational study. *Emerg. Med. J.*, 24(9), Page(s): 665–668, Sept, 2007.

[6] Durable medical equipment. http://en.wikipedia.org/wiki/Durable_medical_equipment

[7] Baseline country survey on medical devices, 2013 update: Medical Equipment- Total density per million population computed tomography. http://gamapserv.who.int/gho/interactive_charts/health_technologies/medical_equipment/atlas.html

[8] B. Norman. What Will You Do if the Power Goes Out? <http://alsn.mda.org/article/what-will-you-do-if-power-goes-out>

[9] HSS Press Office. HSS select winners in idea challenge for emergency response. <http://www.hhs.gov/news/press/2014pres/02/20140220a.html>