



Implementation of sensor Data monitoring and Transmitting Using Raspberry Pi with reference to Healthcare Industry

A.Swapna

MTech Student

Department of Electronics And Communication
Engineering,
CMR Technical Campus,
Kandlakoya, Medchal, Telangana.

Mr. Md.Ammeenuddin

Associate Professor

Department of Electronics And Communication
Engineering,
CMR Technical Campus,
Kandlakoya, Medchal, Telangana.

Abstract: *Healthcare is moving to a digital platform, becoming more patient-centered and data-driven. Large international players such as Microsoft, Qualcomm Life, Philips, Verizon and AT&T have launched ICT-based vertical solutions aimed at the healthcare sector, and the global trend is that ICT solutions are supporting greater sharing and accessibility of health data. This Raspberry Pi assisted mobile health monitoring includes mobile communication as well as computing technologies to provide various services especially feedback decision support using information communication Technologies (ICT's) and mobile healthcare applications for the both parties (Doctors and Patients) involved in this mechanism for better security with extended privacy and data integrity by applying techniques.*

Keywords: *Raspberry Pi, Healthcare industry, Sensors, Bluetooth, Monitoring, PIR Motion Sensors, Communication.*

Introduction:

The electronics technology has entered almost in all aspects of day-to-day life, and the medical field is not exception for that. The need for well-equipped hospitals and diagnostic centers is increasing day by day as the people are becoming more conscious about their health problems. In biomedical fields special units are used, such as intensive care unit or coronary care unit. All of these units are designed to offer the advantage of the low Nurse – Patient ratio and concentration of the equipment and the resources

needed; to take care of critically ill or seriously injured units. The medical world today faces two basic problems when it comes to patient monitoring, firstly the need of healthcare providers present bedside the patient and secondly the patient is restricted to bed and wired to large machines. In order to achieve better quality patient care, the above cited problems have to be solved. As the technologies are advancing it has become feasible to design to home based vital sign monitoring system to display, record and transmit signals from human body to any other location.

The Raspberry Pi based prototype has interfaces which are easy to use, and can help prototype has interfaces which are easy to use and can help designers in investigation and development of new sensors for future sensors. In this design, we use an accelerometer sensor, PIR motion sensor to implement the Security mechanism for the Sensor Node to avoid the possible software attacks and thereby eliminate the threats to safety, security and privacy of any industrial application system. Both safety and reliability of the sensor data is an important issue that needs to be addressed in these fields

Hence, Raspberry Pi being the cheapest and one of the smallest credit cardsize computer which available in the market is the best choice for designing a sensor module We plan to improve upon the design of the prototype by making it a battery operated to start the sensor The prototype can be used to implement other sensors and to investigate other encryption techniques

along with new investigate other encryption techniques along with new interfaces like Bluetooth.

EXISTING SYSTEM

The paper “SECURE SENSOR USING RASPBERRY PI” using ARM-11 process is an exclusive project which is controlled through sensor nodes which we get the message to alert the patient monitoring through Android mobile using Bluetooth. Here we are giving sensor node to the wheelchair of the patient to monitor him/her by a nurse or else any other, by using this sensor we can monitor the movements of the patient when he/she is in wheelchair. Here wheelchair can be moved in all directions like (right, left, reverse, forward) through predefined keys assigned from the DC Motor.

PROPOSED SYSTEM

A unique design of a secure sensor node prototype has been proposed and implemented, which communicates over Bluetooth using RC4 encryption algorithm between a mobile phone and their monitoring equipment. The design uses an accelerometer based sensor, which can be used as a prototype for a body sensor for fall detection in elderly people. The data from the sensor is processed, encrypted and wirelessly communicated by Raspberry Pi (a Single Board Computer) to a mobile phone. The security issues have been addressed in two ways. Firstly, the loss of data is prevented by introducing a wired connection between the Raspberry Pi and the accelerometer based sensor. Secondly, a secure data communication is ensured by encrypting the sensor data using an encryption key sent from the mobile phone using Bluetooth.

A unique design and implementation of a secure sensor node has been carried out based on three major components: a single board computer, an accelerometer based sensor-ADXL345 and a Bluetooth Dongle. Subsidiary components have been used to setup the secure sensor node prototype.

Features:

1. Simple Gesture Based robot directions control.
2. Bluetooth based wireless communication.

3. PIR sensor based Intruder alert system.
4. Android GUI app based feedback system.
5. Embedded Linux programming.
6. Low power consumption.
7. Easy and very userfriendly.
8. Highly efficient design.

The project provides exposure to following technologies:

1. Interfacing MEMS accelerometer sensor to Raspberry pi processor.
2. Interfacing bluetooth, PIR sensors to Raspberry pi processor.
3. Bluetooth based communication and its principles.
4. DC motors interfacing to Raspberry pi processor.
5. DC motor principles.
6. Embedded Linux programming.

The major building blocks of the project are:

1. Power Supply.
2. Raspberry pi processor.
3. Bluetooth Module.
4. MEMS 3-axis accelerometer sensor.
5. PIR sensor.
6. DC motors with motor Driver.
7. Buzzer alarm.
8. Android application.

Block Diagram:

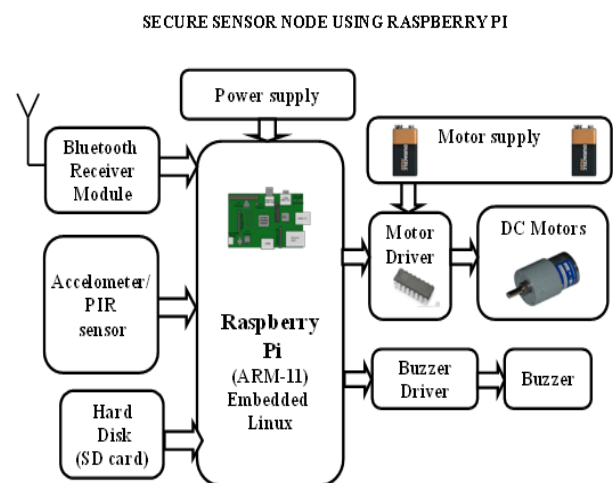

The choice of the single board computer depends on the kind of application which the sensor node uses. Here, we are using it to design a body sensor module which will interface a number of sensors. Raspberry Pi has been chosen for this application. Table 1 gives the comparison between the two most used single board computers in market to justify the use of Raspberry Pi. Among other SBCs, Raspberry Pi is the cheapest single board computer available with the best performance/cost and RAM/cost ratio. Its small size, low cost, low power consumption and high processing power makes it suitable for the design of this body sensor.

Table1: COMPARISON BETWEEN MOST SINGLE BOARD COMPUTERS

Features	Beagle Bone	Raspberry Pi	Panda Board
Single-core/Multi-core frequency	Single-core/70MHz	Low power single-core/700MHz	Dual-core/1GHz
Area	45 cm ²	45 cm ²	115 cm ²
RAM	256 MB	512 MB	1 GB
Price	\$133	\$35	\$500

The **Raspberry Pi** is a credit-card-sized single-board computer developed in the UK by the Raspberry Pi Foundation. The Raspberry Pi has a Broadcom BCM2835 system on a chip (SoC), which includes an ARM1176JZF-S 700 MHz processor, Video Core IV GPU, and was originally shipped with 256 megabytes of RAM, later upgraded to 512 MB. It does not include a built-in hard disk or solid-state drive, but uses an SD card for booting and long-term storage.

Sensor Networks:

Sensor networks are no longer expensive industrial constructs. You can build a simple sensor network from easily procured, low-cost hardware. All you need are some simple sensors and a microcontroller or computer with input/output capabilities. Yes, your Arduino and Raspberry Pi are ideal platforms for

building sensor networks. If you’ve worked with either platform and have ever wanted to monitor your garden pond, track movement in your home or office, monitor the temperature in your house, monitor the environment, or even build a low-cost security system, you’re halfway there! As inviting and easy as that sounds, don’t start warming up the soldering iron just yet. There are a lot of things you need to know about sensor networks. It’s not quite as simple as plugging things together and turning them on. If you want to build a reliable and informative sensor network, you need to know how such networks are constructed. In this chapter, we will explore sensor networks through a brief description of what they are and how they are constructed. We will also examine the components that make up a sensor network including an overview of sensors; the types of sensors available and the things that they can sense.

Implementation Pictures:

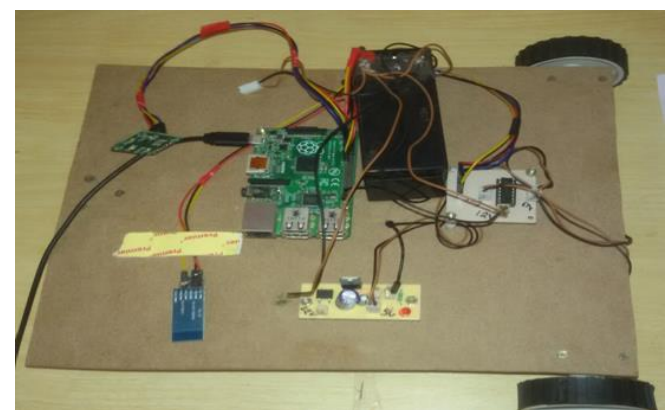

Fig: Raspberry Pi with sensor nodes

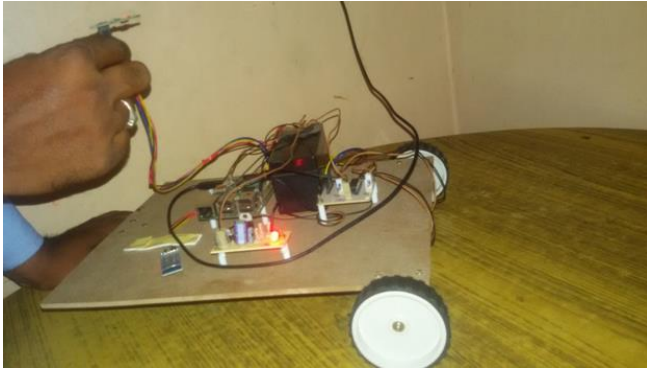

Fig: image is in working mode:

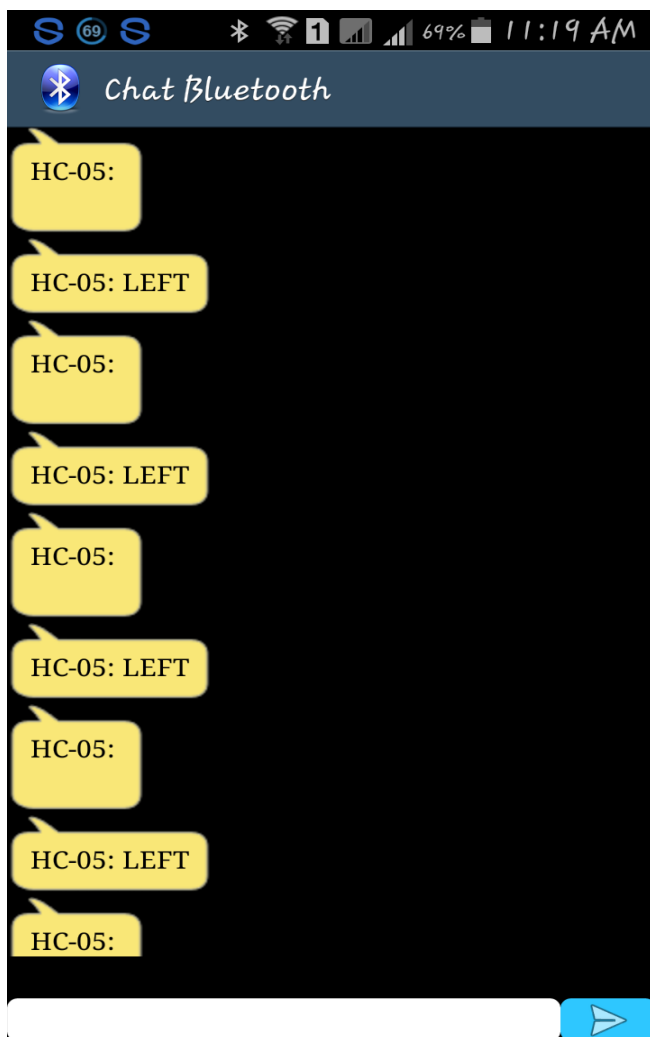

Fig: This Image Represents The Resultant Output
Image

Conclusion:

Raspberry pi smart, economic and efficient platform for implementation in Healthcare Industry. This system reduce costs by enabling in-horne monitoring of patients, eliminating the need for utilization of expensive facilities, and reducing the need for transportation of patients to physicians and medical centers.

FUTURE ENHANCEMENT

- ✓ The system can be extended by interfacing wireless technologies like GPS, GSM etc.
- ✓ By connecting GSM modem we can send the alerting messages about fire detection and human presence detection to the predefined numbers.
- ✓ We can extend the project by adding sensors for monitoring the environmental conditions and alerts the user in android mobile itself.

References:

- [1] Banerjee.S, Sethia.D, Mittal.T, Arora.U & Chauhan.A, Secure sensor node with Raspberry Pi, Multimedia, Signal Processing and Communication Technologies (IMPACT), 2013 International Conference.
- [2] Ying-Wen Bai, Chien-Yung Cheng, Chou-Lin Lu and Yung-Song Huang, "Design and Implementation of an Embedded Remote ECG Measurement System" IMTC 2005 - Instrumentation and Measurement Technology Conference Ottawa, Canada 17-19 May 2005
- [3] Nivedita Daimiwla, Asmita Wakankar, Dipali Ramdasi and Mrunal Chandratreya "Microcontroller Based ECG and Blood Pressure Simulator"- J. Instrum. Soc. India 37(4) 243-248.
- [4] Mohamed Fezari, Mounir Bousbia-Salah, and Mouldi Bedda "Microcontroller Based Heart Rate



Monitor" The International Arab Journal of Information
Technology, Vol. 5, No. 4, October 2008.

[5] M. Chaitanya Suman, K. Prathyusha "Wireless
ECG System Based on ARM LPC 2103 Processor"
IJECT Vol. 3, Tissue I, Jan. - March 2012, ISSN :
2230-7109 (Online) I TSSN : 2230-9543 (Print).

[6] M. B. 1. Reaz "Tele-Health ECG Monitoring
System: A Low Cost Approach" International Islamic
University Malaysia, Kuala Lumpur, Malaysia.

[7] C.S. BUffUS, R.A. Gopinath, H. Guo, (1997)
Introduction to Wavelets and Wavelet Transforms. a
Primer, Prentice Hall Inc.

[8] R.S. Khandpur, Handbook of Biomedical
instrumentation.

Author Details:



A. Swapna



Mr. Md. Ammeenuddin