

An Improved Performance Power Electronics Interface for Battery Based Electric Vehicles



Anusha.K

M.Tech Student,
Department of EEE,
SSJ Engineering College.



Sajith Shaik

Assistant Professor,
Department of EEE,
SSJ Engineering College.



Ch Vinay Kumar

Associate Professor,
Department of EEE,
SSJ Engineering College.

Abstract:

A novel integrated power electronics interface (IPEI) for battery electric vehicles (BEVs) in order to optimize the performance of the power train is proposed in this paper. As Power electronics interfaces plays important role in the automotive vehicle technologies the proposed IPEI is responsible for the power-flow management for each operating mode. The operating modes will explain how IPEI works during different modes like charging/discharging and traction/breaking modes. In this concept, an IPEI is proposed and designed to realize the integration of the dc/dc converter, on-board battery charger, and dc/ac inverter together in the BEV power train with high performance. The proposed concept improves the system efficiency and reliability, and reduces the current, voltage ripples, and also reduces the size of the passive and active components in the BEV drive trains compared to other topologies. And control strategy for IPEI is designed and analyzed by using MATLAB/Simulink. The simulation results related to the output waveforms are obtained and validated.

I. INTRODUCTION:

The interest in electric vehicles has increased rapidly over the past few years. An important milestone was reached in 2012 with more than 100,000 hybrid and all-electric vehicles sold globally, and sales figures are approximately doubling each year. Many automobile manufacturers have at this point already developed and commercialized their first electric models, proving that the electric drive is technically viable, environmentally friendly and affordable.

Thus, manufacturers are approaching a subsequent phase in their development efforts that entails building powerful, long-range, fast-charging, more efficient and cheaper electric vehicles. This makes it a good time to think beyond proof-of-concept solutions, and to make intelligent choices for the next-generation electric drive technologies that once and for all give electric vehicles its rightful place in the transportation market. The concern with all-electric vehicles (EV) is their limited driving range on a fully charged battery. This is usually between 100km and 500km for a modern EV.

At the same time, the refueling time for an electric vehicle is long, ranging from 30 minutes to 10 hours or more. Therefore, consumers feel this is too restrictive and stick with their conventional gasoline vehicle (GV) that can be refueled almost anywhere in 5-10 minutes or less. There are many ways to mitigate the problem of range anxiety for EVs, one of which is the focus of this report, namely fast-charging. The basic idea is that if the charging power of the vehicle can be increased, then the time to charge the vehicle is lowered correspondingly. If the charging time is less than around 30-60 minutes then en-route charging is possible, given that charging stations have been installed at appropriate locations. Charging times of around 2-4 hours are also useful, since that enables charging at e.g. a work place or other sites where the vehicle is parked during the day. This effectively doubles the driving range, because the vehicle can be fully recharged before it returns to its over-night charging spot. For instance, if a vehicle with a driving range of 200km is charged at its destination then its effective range is 400km. A study on US consumers' driving range gives a conservative estimate of possible

EV penetration with a widely deployed fast charging infrastructure.. With a vehicle range of 400km, 45% of all vehicles can be replaced with EVs without constraining the user's driving behaviour. This corresponds to a global market of more than 450 million vehicles that could be EVs today. In one approach, the traction motor windings have been used as the inductors for the converter to develop the charging system without any additional component. The three-phase supply is connected with each phase of the machine and the battery is always connected to the dc bus. The research showed the use of a poly-phase machine for the charger. Other topologies have been used for battery charging systems with traction motor windings used as filter components. An on-board integrated charger has been proposed with reconfiguration of the stator windings of a special electric machine in. A battery charger is developed for the electric scooter, where interior permanent magnet traction motor is used for charging with power factor correction .

The interleaving technique is another interesting approach used in designing dc-dc converters for reduced switching stresses and increased efficiency .The approach reduces the size and power rating of the converter passive components. Low EMI and low stress in the switches can be expected from the interleaved converter phase legs. However, there is one possible show stopper in this equation. If the fast-charging equipment turns out to be expensive or otherwise infeasible then it is unlikely to become widely adopted, and EV penetration will be considerably lower due to the aforementioned range anxiety. The cost of the charging equipment is therefore a major concern, and will become even more so when public funding for infrastructure pilot projects declines in the future. This project focuses on driving down cost of fast-charging equipment by charging the EV with power from an AC charging station connected directly to the electrical grid. The current approach to EV fast-charging uses DC chargers, which are bulky and pricy because they contain additional high power circuitry to convert the grid's AC into DC. The approach in this project is to investigate a concept known as an integrated motor drive, where the existing traction components onboard the vehicle are reused for the purpose of charging the battery also. This eliminates redundancy in power electronics hardware and should thus come at little additional cost to the vehicle manufacturer.

On the infrastructure side, an AC charging station is required, which runs the power wires directly from the grid to the car and can therefore be constructed as simple, small and inexpensive units. This project encompasses many topics ranging from high power electronics onboard the vehicle to load management algorithms in the charging station. This holistic approach is necessary to efficiently select the charging solution that lowers overall system cost and provides the most benefits for the stakeholders of the EV industry, including the EV users. Therefore, it is essential to investigate and discuss a wider range of technologies from the perspective of both the EV and the charging station.

In this project, an integrated motor converter is proposed that can be used as the traction motor drive, a battery charger, and a power converter to transfer energy from vehicle-to-grid (V2G) through reconfiguration of the inverter topology using relays or contactors. The traction inverter with the proposed reconfiguration method can also transfer power from the vehicle to a dc grid and from a dc grid to the vehicle using the traction motor windings with the appropriate relay settings. The three-phase machine windings and the three inverter phase legs can be utilized with an interleaved configuration to distribute the current and reduce the converter switching stresses.

The battery voltage is increased in the boost mode to an output reference voltage level within the limits of the machine ratings. A soft starter method using PWM control has been used to reduce the starting current overshoot when connecting to a dc grid. In a dc grid connected mode, the voltage drop across the inductor will be the difference between the inverter output voltage and the dc grid voltage. The dc grid voltage provides more stable voltage to counteract the rate of change of inductor current and the current ripple is controlled in a better fashion in a dc grid connected mode.

II. PROPOSED CIRCUIT

Why Electric Vehicles?

Why concern ourselves with EVs when they have limited range and hence seem inferior to other types of vehicles? After all, other types of environment-friendly vehicles exist. Most notably, plug-in hybrid electric vehicles (PHEV) are becoming increasingly popular.

This type of vehicle carries both a conventional gasoline engine along with a battery and an electric motor, and the battery can be charged by plugging into an outlet or a charging station. As such, the PHEV attempts to use the best of two worlds: The long driving range is provided by the conventional gasoline engine, while the electric powertrain makes the vehicle efficient and clean. By using technologies such as regenerative braking and running the engine only at rpms where it has maximum efficiency give the PHEV a high mileage and low emissions. However, there are two major downsides to the PHEV concept:

1. A hybrid vehicle is still highly dependent on gas.
2. A hybrid vehicle is much more complex since it has two powertrains. This makes the vehicle more expensive in upfront cost and in maintenance compared to both gasoline vehicles and electric vehicles that rely on a single powertrain.

In combination with these reasons, some countries, such as Denmark, are currently not offering tax deductions on hybrid vehicles, while EVs are often fiscally incentivized. For example, EVs are in Denmark exempt from the 180% registration tax that is put on both hybrid and gasoline personal vehicles. In the US, a tax credit worth \$7,500 is offered on both EVs and hybrids. Whereas the hybrid and the gasoline vehicle relies on a rather complex powertrain, an electric vehicle is on the other hand quite simple. It consists of mainly three parts: There is still 25% VAT on EVs. The exact registration tax for a vehicle is a somewhat complicated calculation, but it is approximately 105% up to a car value of 79,000 DKK and 180% above, see.

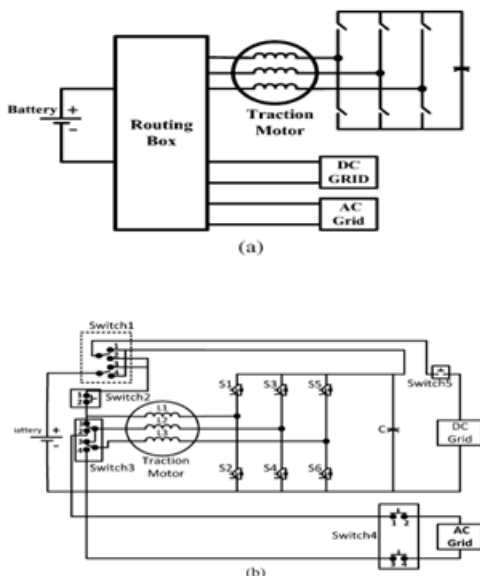

Fig. 1. Converter with switches capable of interfacing with both ac and dc grid (a) combined and (b) details

CIRCUIT OPERATION :

The circuit operation has been explained below in a tabular form

TABLE I
SWITCH POSITIONS AND CONVERTER STATES

Switch	State 1	State 2
Switch1	Pole positions: 1 and 3	Pole positions: 2 and 4
Switch2	1 and 2 disconnected	1 and 2 connected
Switch3	Pole positions: 1 and 3	Pole positions: 2 and 4
Switch4	1 and 2, and 3 and 4 disconnected	1 and 2, and 3 and 4 connected
Switch5	1 and 2 disconnected	1 and 2 connected

III. CONTROL STRATEGY:

Pulse-width modulation (PWM), as it applies to motor control, is a way of delivering energy through a succession of pulses rather than a continuously varying (analogy) signal. By increasing or decreasing pulse width, the controller regulates energy flow to the motor shaft. The motor's own inductance acts like a filter, storing energy during the "on" cycle while releasing it at a rate corresponding to the input or reference signal. In other words, energy flows into the load not so much the switching frequency, but at the reference frequency. PWM is somewhat like pushing a playground-style merry-go-round.

The energy of each push is stored in the inertia of the heavy platform, which accelerates gradually with harder, more frequent, or longer-lasting pushes. The riders receive the kinetic energy in a very different manner than how it's applied. The main advantage of PWM is Efficiency. PWM amplifiers run cooler than standard linear power amps, requiring substantially less heat sink mass. At about 90% efficiency, PWM makes electromagnetic motion feasible at power levels where hydraulics used to be the only option.

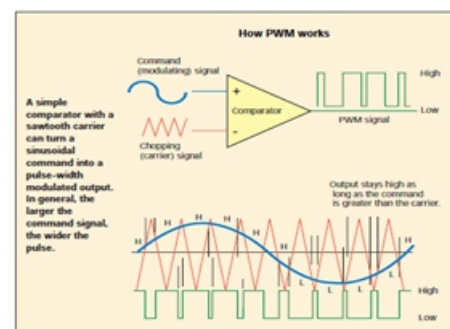

Fig.2. PWM Strategy

IV. SIMULATION RESULTS:

Simulation Circuit:

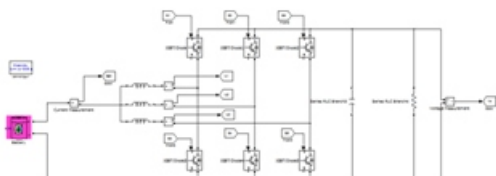

Fig.3. Boost Mode Circuit

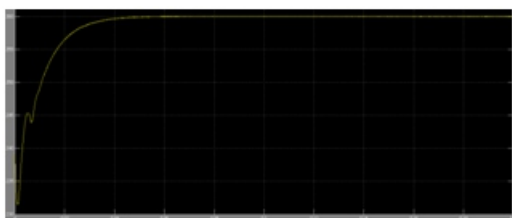

Fig .4. Load Voltage (Vo)

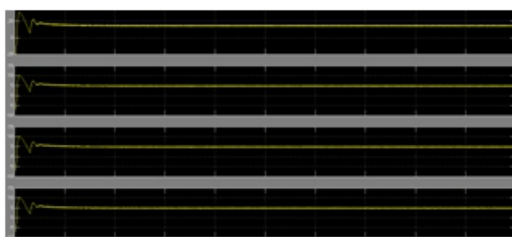

Fig.5. Batter current, phase winding currents of a,b,c

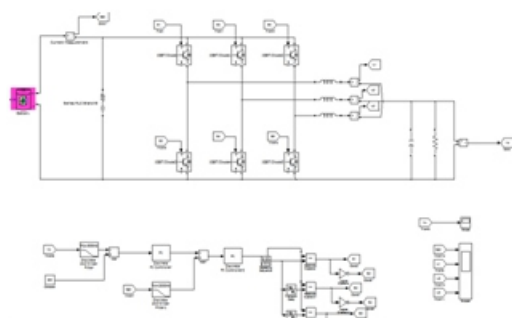

Fig.6. Buck Mode Circuit

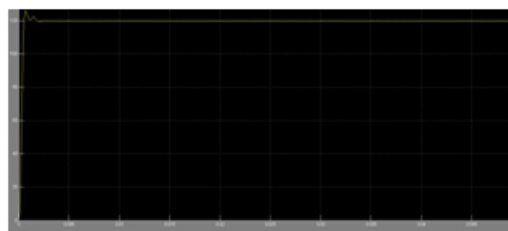

Fig.7. Load Voltage (Vo)

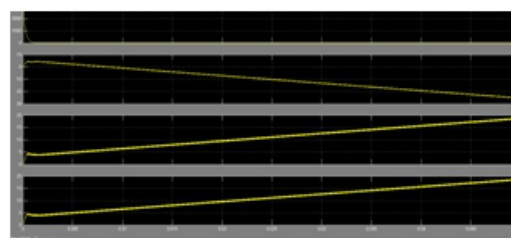

Fig.8. Batter current, phase winding currents of a,b,c

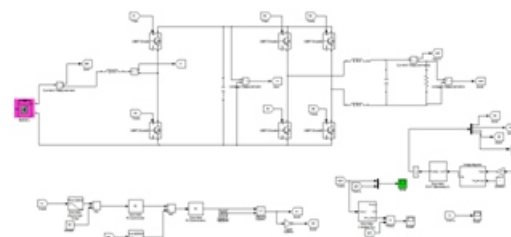

Fig.9. Power flow from battery to ac grid Circuit

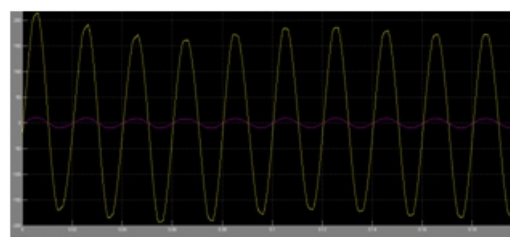

Fig.10. Grid Voltage & Grid Current

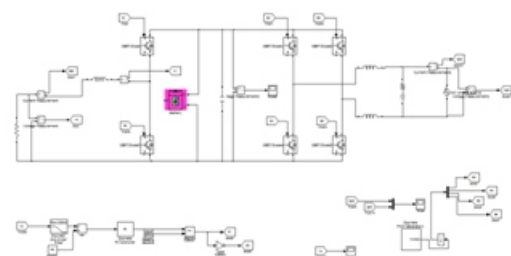

Fig.11. Power flow from ac grid to battery circuit

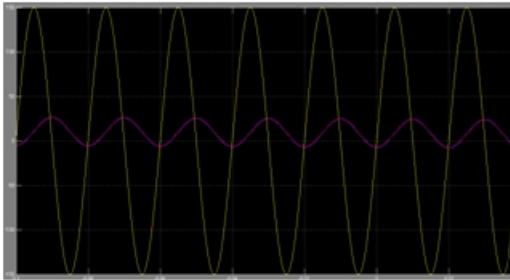

Fig.12. . Grid Voltage & Grid Current

V. CONCLUSION:

A novel integrated power electronic interface for BEV (Battery Electric Vehicle) which optimizes the performance of the power train is proposed. The proposed concept of APEI (Advanced Power Electronics Interface) combines the features of the BMDIC (Bi-directional Multi Device interleaved DC-DC converter) and the ESI (Eight Switch Inverter). The proposed APEI and its performance characteristics had been analyzed and presented. Different control strategies are designed to verify the performance of the proposed APEI during different operating modes. It should be pointed out that the IFOC based on PWM voltage is more efficient which is used to drive the EM (Electric Machine) during traction and braking modes. Moreover, the proposed APEI can achieve a high power factor correction, and can achieve a low THD for the input current during charging mode from the ac grid. As is clear from the simulation results, the proposed APEI can reduce the current and voltage ripples, can improve the efficiency and reliability, and can provide a compact size for the BEV power train. Furthermore, the battery lifespan can be increased due to the ripple reduction. Finally, the results of simulation are demonstrated for the proposed APEI has been successfully realized and it promises significant savings in component count with high performance for BEVs compared to other topologies. Therefore, it can be expected that these topologies can be utilized for development of high efficiency BEV power trains.

REFERENCES:

[1]. C. C. Chan, A. Bouscayrol, and K. Chen, "Electric, hybrid, and fuel-cell vehicles: Architectures and modeling," IEEE Trans. Veh. Technol., vol. 59, no. 2, pp. 589–598, Feb. 2010.

[2]. C. C. Chan, "The state of the art of electric and hybrid, and fuel cell vehicles," Proc. IEEE, vol. 95, no. 4, pp. 704–718, Apr. 2007.

[3]. A. Emadi, S. S. Williamson, and A. Khaligh, "Power electronics intensive solutions for advanced electric, hybrid electric, and fuel cell vehicular power systems," IEEE Trans. Power Electron., vol. 21, no. 3, pp. 567–577, May 2006.

[4]. A. Emadi, Y. J. Lee, and K. Rajashekara, "Power electronics and motor drives in electric, hybrid electric, and plug-in hybrid electric vehicles," IEEE Trans. Ind. Electron., vol. 55, no. 6, pp. 2237–2245, Jun. 2008.

[5]. S. S. Raghavan, O. C. Onar, and A. Khaligh, "Power electronic interfaces for future plug-in transportation systems," IEEE Power Electron. Soc. Newsletter, vol. 23, Third Quarter 2010.

[6]. Y.-J. Lee, A. Khaligh, and A. Emadi, "Advanced integrated bidirectional AC-DC and DC-DC converter for plug-in hybrid electric vehicles," IEEE Trans. Veh. Technol., vol. 58, no. 8, pp. 3970–3980, Oct. 2009.

[7]. M. Pahlevaninezhad, P. Das, J. Drobnik, P. K. Jain, and A. Bakhshai, "A new control approach based on the differential flatness theory for an AC/DC converter used in electric vehicles," IEEE Trans. Power Electron., vol. 27, no. 4, pp. 2085–2103, Apr. 2012.

[8]. Z-Source Inverter for Fuel Cell Vehicles, Oak Ridge Nat. Lab., Oak Ridge, TN, USA, Sep. 2005.

[9]. S. Miaosen, "Z-source inverter design, analysis, and its application in fuel cell vehicles," Ph.D. dissertation, Michigan State Univ., East Lansing, USA, 2007.

[10]. M.-K. Nguyen, Y.-C. Lim, and G.-B. Cho, "Switched-inductor quasi-Zsource inverter," IEEE Transaction. power electron volume no.26 pp.3183–3191, Nov. 2011.

Authors Details:

ANUSHA.K Received B.Tech degree from megha institute of engineering & technology for women, edulbad(v), ghatkesar (m), r.r dist.,Telangana in 2013. And currently pursuing M.Tech in power electronics at ssj engineering college, vattinagulapally, gandipet, Hyderabad, Telangana. Her area of interest are in power electronics and drives, power systems.

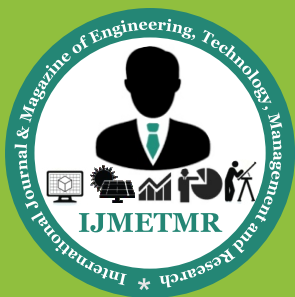

SAJITH SHAIK Obtained his B.tech (EEE) degree from university college of engineering (kakatiya university), kothagudem, khammam dist., M.Tech. (Power electronics) from tkr engineering college, meerpet, r.r dist.,. He is working as Asst. Prof. in ssj Engineering college Hyderabad. His areas of interest include power electronics, electrical circuits. He is having 2 years teaching experience.

CH.VINAY KUMAR Obtained his B.TECH (EEE) degree from ST.MARTINS ENGG COLLEGE, HYD., M.Tech. (Power Electronics) from JNTU Hyderabad. Currently he is working as Assoc. Prof. in SSJ Engineering college, Hyderabad. His areas of interest include Power Electronics & Drives, Power systems and Facts. He is having 8 years of teaching experience.