

Performance Evaluation of Multi-Level Inverter (MLI) Used in Low Power Renewable Energy Sources



G.Gopaiah Swamy
M.Tech Student, Power Electronics,
Department of EEE,
Anurag Engineering College,
Kodad, Nalgonda, T.S, India.



J.Srinivasa Rao
Associate Professor
Department of EEE,
Anurag Engineering College,
Kodad, Nalgonda, T.S, India.

Abstract:

Today, with the focus on greener sources of power, PV has become an important source of power for a wide range of applications. Improvements in converting light energy into electrical energy as well as the cost reductions have helped create this growth. Even with higher efficiency and lower cost, the goal remains to maximize the power from the PV system under various lighting conditions. Two dc capacitors, a dual-buck converter, a full-bridge inverter, and a filter configure the five-level inverter. The dual-buck converter converts two dc capacitor voltage sources to a dc output voltage with three levels and balances these two dc capacitor voltages. design and validation of a Maximum Power Point Tracking (MPPT) capable of tracking the true Global Maximum Power Point (GMPP) in the presence of other local maxima. The five-level inverter output current is controlled to produce current in phase with utility voltage to inject into grid. The performance characteristics of the proposed converter are verified by MATLAB/simulink software, they are described in simulation results section.

Index terms:

Low-power energy sources, single-stage boost converter, MPPT algorithm, Renewable Energy Sources, Multi-level Inverter.

I.INTRODUCTION:

The demand for renewable energy has increased significantly over the years because of shortage of fossil fuels and greenhouse effect.

Among various types of renewable energy sources, solar energy and wind energy have become very popular and demanding due to advancement in power electronics techniques. Photo-Voltaic (PV) sources are used today in many applications as they have the advantages of being maintenance and pollution free [1]. Solar-electric-energy demand has grown consistently by 20%–25% per annum over the past 20 years, which is mainly due to the decreasing costs and prices. Due to the day by day increasing energy demand, shortage and environmental impacts of conventional energy sources, more attention has been given to utilize the renewable energy. In a tropical Asian country like India, the most promising alternative of renewable green energy resource of the future is the sun. Since this energy source is free, abundant, feasible and environmental friendly, it become more popular. Although there are several benefits in solar energy, there are some challenges that obstruct its growth. The two main challenges are low conversion efficiency and its erratic nature of power output. Basically MLI's are classified in to two types. They are

- (1) Cascaded MLI's,
- (2) Parallel MLI's

The single-phase conventional multilevel inverters are having different topologies, they are diode-clamped, flying capacitor, and cascaded H-bridge inverters. In the proposed paper a special five-level inverter is developed. The developed five-level inverter is having six power electronic devices, two capacitors and two high-frequency switching switches. The voltage balancing of capacitors is easier when compared to the other multilevel inverters.

Maximum power point tracking is an essential part of a photovoltaic system. Photovoltaic systems have a distinct operating point that provides maximum power. An MPPT actively seeks this operating point. Maximum Power Point Tracking, normally known as MPPT, is an electronic arrangement that find the voltage (VMPP) or current (IMPP) routinely at which a PV module should operate to achieve the maximum power output (PMPP) under rapidly-changing environmental conditions. It operates the PV modules in a way that permits the modules to generate all the power they are capable of. The proposed converter configured by two dc capacitors, two diodes, and four power electronic switches. Two diodes are used to conduct the current loop, and four power electronic switches are used to control the voltage levels. The output voltage of the basic diode-clamped multilevel inverter has three levels. The voltage difference of each level is $V_{dc}/2$ (the voltage on a capacitor). Since the voltages of two dc capacitors are used to form the voltage level of the multilevel inverter, the voltages of these two dc capacitors must be controlled to be equal. The control for balancing these two dc capacitors is very important in controlling the diode-clamped multilevel inverter, and it is very hard under the light load. The voltage on each dc capacitor is controlled to be $V_{dc}/2$, and the output voltage of the basic flying capacitor multilevel inverter has three levels.

The voltage difference of each level is also $V_{dc}/2$ (the voltage on a dc capacitor). The paper is organized as follows: The section II describes the circuit design of multilevel inverter. The operating modes of five-level inverter are mentioned in section III. Section IV describes the control strategy for five-level inverter. Simulation results are observed in section V, and finally conclusion mentioned in section IV.

II. CIRCUIT DESCRIPTION:

Circuit design of proposed five-level inverter interconnected with photovoltaic energy conversion system is shown in figure 1. It is configured by a PV-Array, a dc-dc converter, a five-level inverter, two switches, and control circuit for the switching devices. The switches SW_1 and SW_2 are used to connect or disconnect the photovoltaic power generation system from the utility system. The load is connected in between switches SW_1 and SW_2 . The DC-DC converter is connected across output terminals of PV-array. The output ports of the dc-dc converter are connected to the five-level inverter input side. The DC-DC converter operated as boost converter, and it is fed by control circuit of maximum power point tracking algorithm to deliver maximum output power from solar cell array.

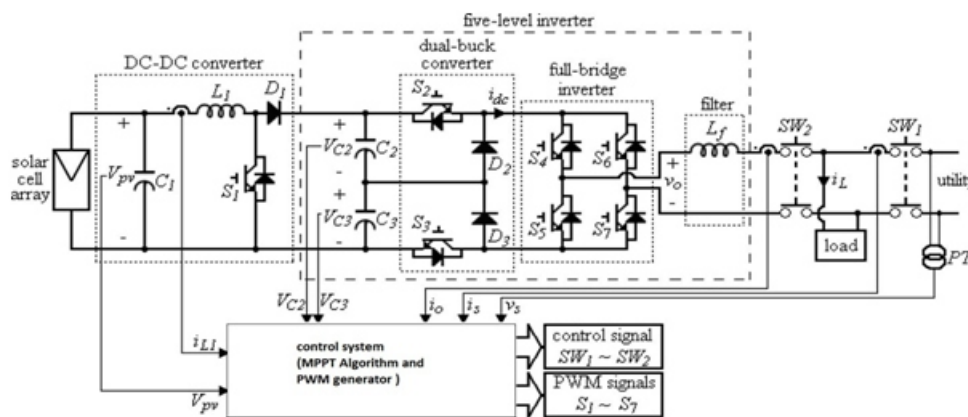

Figure 1: Circuit design of five-level inverter interfaced with PV energy conversion system

Five-level inverter is configured by two dc capacitors, a dual-buck converter, a full-bridge inverter, and a filter. The dual-buck converter is configured by two buck converters. For the energy buffering between dc-dc converter and five-level inverter is done by connecting two dc capacitors [3]. The output of the dual-buck converter is connected to the full-bridge inverter to convert the dc voltage to ac voltage.

The high-frequency switching harmonics are eliminated by connecting inductor at output of full-bridge inverter which is caused by buck converter. The dc bus voltage of each full-bridge inverter is $V_{dc}/2$, and the output voltage of each full-bridge inverter can be controlled to be $V_{dc}/2$, 0, and $-V_{dc}/2$. Thus, the voltage levels of the output voltage of the cascade full-bridge multilevel inverter are V_{dc} , $V_{dc}/2$, 0, $-V_{dc}/2$, and $-V_{dc}$.

This topology has advantages of fewer components being required compared with other multilevel inverters under the output voltage with the same levels, and its hardware circuit can be modularized because the configuration of each full bridge is the same.

III. MODES OF OPERATION:

Operation principle of five-level inverter is explained in this section. The proposed converter is operated in eight (8) modes [4]. The positive half-cycle conversion is done in modes 1-4. And negative cycle in modes 5-8. The operation modes of this five-level inverter are explained as below:

Mode 1: The power electronic switch of the dual-buck converter S_2 is turned ON and S_3 is turned OFF. DC capacitor C_2 is discharged through S_2 , S_4 , the filter inductor, the utility, S_7 , and D_3 to form a loop. Both output voltages of the dual-buck converter and five-level inverter are $V_{dc}/2$.

Mode 2: The power electronic switch of the dual-buck converter S_2 is turned OFF and S_3 is turned ON. DC capacitor C_3 is discharged through D_2 , S_4 , the filter inductor, the utility, S_7 , and S_3 to form a loop. Both output voltages of the dual-buck converter and five-level inverter are $V_{dc}/2$.

Mode 3: Both power electronic switches S_2 and S_3 of the dual-buck converter are turned OFF. The current of the filter inductor flows through the utility, S_7 , D_3 , D_2 , and S_4 . Both output voltages of the dual-buck converter and five-level inverter are 0.

Mode 4: Both power electronic switches S_2 and S_3 of the dual-buck converter are turned ON. DC capacitors C_2 and C_3 are discharged together through S_2 , S_4 , the filter inductor, and the utility, S_7 , and S_3 to form a loop. Both output voltages of the dual-buck converter and five-level inverter are V_{dc} .

Modes 5-8: These operating modes for the negative half-cycle. The operations of the dual-buck converter under modes 5-8 are similar to that under modes 1-4, and the dual-buck converter can also generate three voltage levels $V_{dc}/2$, $V_{dc}/2$, 0, and V_{dc} , respectively. However, the operation of the full-bridge inverter is the opposite.

The power electronic switches S_4 and S_7 are in the OFF state, and the power electronic switches S_5 and S_6 are in the ON state during the negative half-cycle. Therefore, the output voltage of the five-level inverter for modes 5-8 will be $-V_{dc}/2$, $-V_{dc}/2$, 0, and $-V_{dc}$, respectively. Considering operation modes 1-8, the full-bridge inverter converts the dc output voltage of the dual-buck converter with three levels to an AC output voltage with five levels which are V_{dc} , $V_{dc}/2$, 0, $-V_{dc}/2$, and $-V_{dc}$. The waveform of output voltage of five-level inverter is shown in Fig. 2.

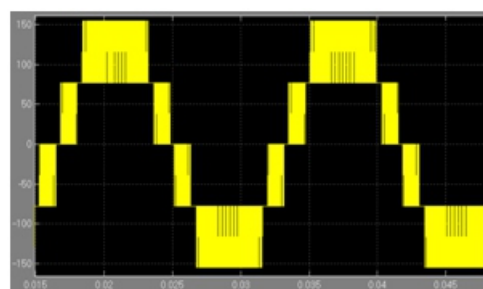

Figure 2: Output voltage of proposed inverter

DC-capacitors voltage balancing

The operation of the multilevel inverter is depends on controlling of dc capacitor voltages. Those voltages are represented as V_{c2} and V_{c3} and they are controlled by switches S_2 and S_3 easily [5]. If utility voltage is less than $V_{dc}/2$, one switch either S_2 or S_3 is switched in high frequency and other in OFF state. If utility voltage is higher than $V_{dc}/2$, one switch either S_2 or S_3 is switched in high frequency and still in the ON state.

IV. CONTROL STRATEGY:

For these converters two different control strategies are performed. The MPPT control algorithm is used for dc-dc converter for generating switching signals and performs the MPPT to extract the maximum output power of the solar cell array.

Maximum Power Point Tracking (MPPT) algorithm:

Maximum Power Point Tracking (MPPT) algorithm is used for getting of maximum power from solar array [6]. The output of the MPPT controller is the desired output voltage of the solar cell array, and it is the reference voltage of the outer voltage control loop.

For the proposed system P&O (perturbed and observation) method is designed. The control block diagram of MPPT Algorithm is shown in figure 4.

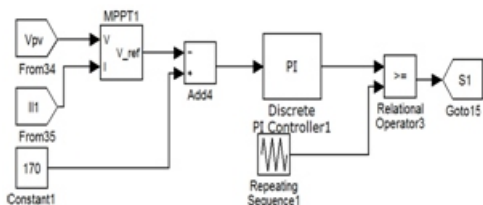

Figure 3: MPPT controller

The output voltage of the solar cell array is perturbed first, and then the output power variation of the solar cell array is observed to determine the next perturbation for the output voltage of the solar cell array. The output power of the solar cell array is calculated from the product of the output voltage of the solar cell array and the inductor current. Therefore, the output voltage of the solar cell array and the inductor current are detected and sent to a MPPT controller to determine the desired output voltage of the solar cell array.

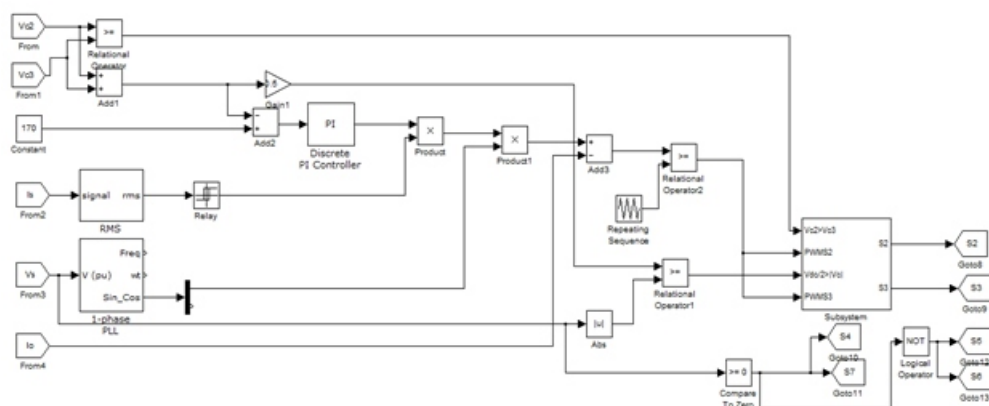

Figure 4: inverter control circuit

The utility RMS current is given to hysteresis comparator, and is sent to signal generator. The outputs of the PI controller and signal generator are sent to a multiplier, and the product of the multiplier is the amplitude of the reference signal. The utility voltage is taken as input for PLL (Phase Locked Loop).

The voltages of dc capacitors C2 and C3 are detected and then added to obtain a dc bus voltage Vdc. Resulting voltage is subtracted from setting voltage, and is sent to PI controller. The outputs of the multiplier and the PLL circuit are sent to the other multiplier. The output current of the five-level inverter is detected by a current sensor.

The detected output voltage and desired output voltage of the solar cell array are sent to a sub-tractor, and the subtracted result is sent to a P-I controller. The output of the P-I controller is the reference signal of the inner current control loop. The reference signal and the detected inductor current are sent to a sub-tractor, and the subtracted result is sent to an amplifier to complete the inner current control loop. The output of the amplifier is sent to the PWM circuit. The output signal of the PWM circuit is the driving signal for the power electronic switch of the dc-dc converter.

Inverter controller:

The operation of the five-level inverter, to convert the dc bus voltage regulated to larger than peak voltage of utility system. The control block diagram of five-level inverter is shown in figure 4. The input of the five-level inverter fed from dc bus, which is connected to output of dc-dc converter [7].

The reference signal and detected signal for the output current of the five-level inverter are sent to a sub-tractor. The subtracted result is sent to a current-mode controller. The output of the current-mode controller is sent to a PWM circuit to generate a PWM signal.

V.SIMULATION RESULTS:

The performance of the proposed photovoltaic energy conversion system is verified by MATLAB/simulink software. The proposed photovoltaic energy conversion system consists of a dc-dc power converter and the five-level inverter. The simulation circuit of proposed system is shown in figure 5.

The environmental temperature and radiation levels are 35.7 deg.C and 944 W/m², respectively. The temperature of the solar module is 55.3 deg. C. The maximum output power of the solar cell array is about 900W.

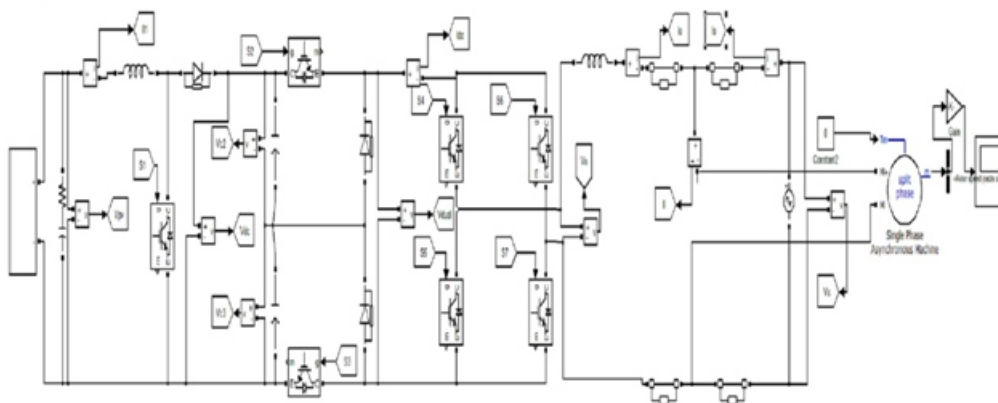

Figure 5: proposed converter with machine load

The simulation results of utility voltage, output current of five-level inverter, and DC capacitor voltages V_{c2}, V_{c3} are shown in figure 6. Simulation results of dc-dc converter are shown in figure 7. The simulation results of Output current (i_o), and input current (i_{dc}) of the full-bridge inverter, (c) Driver signal of S4, Driver signal of S5 are shown in figure 8.

Figure 7: simulation results of (a) Voltage ripple of dc capacitor C2, Voltage ripple of dc capacitor C3, Output voltage ripple of solar cell array, Inductor current ripple of dc-dc converter

Comparison simulation waveforms of utility voltage, inverter output voltage, and output voltage of dual-buck converter are shown in figure 9. The proposed five-level inverter fed with solar energy conversion system is connected to machine load. The performance of the inverter is verified with single-phase asynchronous motor. And finally operation of proposed converter is satisfied with resistive load and machine.

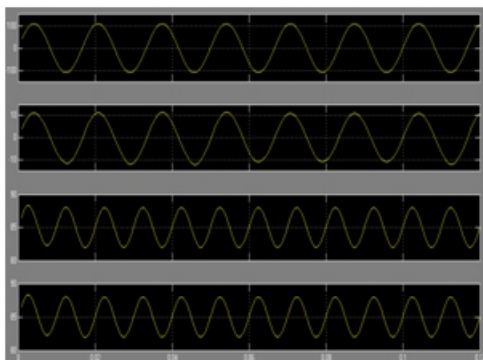

Figure 6: simulation results of the five-level inverter. Utility voltage, Output current of the five-level inverter, DC capacitor voltage V_{c2} , DC capacitor voltage V_{c3} .

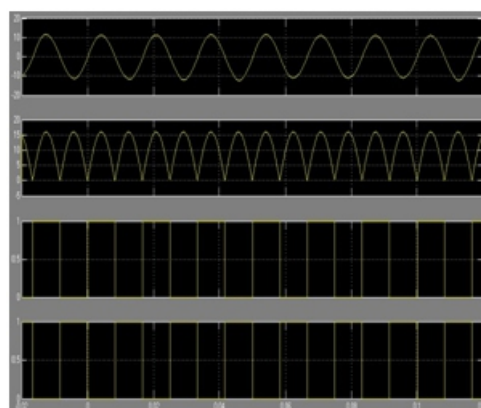
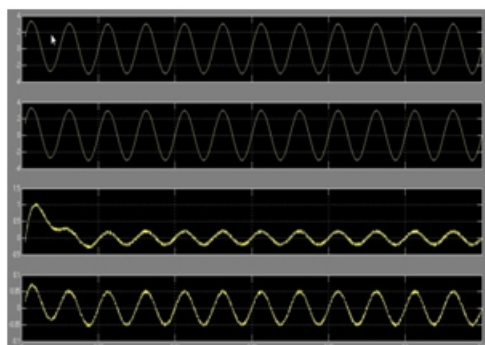

Figure 8: Simulation results of Output current of the full-bridge inverter, Input current of the full bridge inverter, Driver signal of S4, Driver signal of S5.



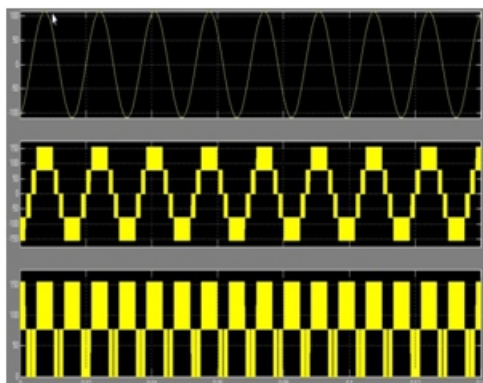

Figure 9: simulation results of the five-level inverter: Utility voltage, Output voltage of the full-bridge inverter, Output voltage of the dual-buck converter.

The rotor speed of the single-phase asynchronous motor is shown in fig 10.

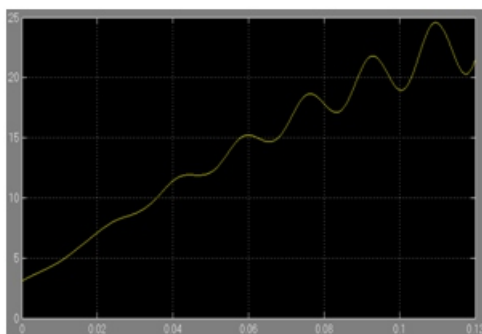

Figure 10: Rotor speed

V.CONCLUSION:

An improved photovoltaic energy conversion system with five-level inverter asynchronous machine load is proposed in this paper. For increasing of power rating of PV array MPPT controller has employed. The performance of proposed inverter topology is verified with resistive load and asynchronous machine, can be observed in the simulations results section. The voltage balancing of capacitors connected to input of inverter

REFERENCES:

- [1] Safety of Power Converters for Use in Photovoltaic Power Systems—Part 2: Particular Requirements for Inverters, IEC 62109-2, Ed.1, 2011.
- [2] M. Chithra and S. G. B. Dasan, “Analysis of cascaded H-bridge multilevel inverters with photovoltaic arrays,” in Proc. Int. Conf. Emerging Trends Elect. Comput. Technol., Mar. 2011, pp. 442–447.
- [3] S. De, D. Banerjee, K. Siva Kumar, K. Gopakumar, R. Ramchand, and C. Patel, “Multilevel inverters for low-power application,” IET Power Electron., vol. 4, no. 4, pp. 384–392, Apr. 2011.
- [4] M. Chithra and S. G. B. Dasan, “Analysis of cascaded H-bridge multilevel inverters with photovoltaic arrays,” in Proc. Int. Conf. Emerging Trends Elect. Comput. Technol., Mar. 2011, pp. 442–447.
- [5] O. Bouhali, B. Francois, E. M. Berkouk, and C. Saudemont, “DC link capacitor voltage balancing in a three-phase diode clamped inverter controlled by a direct space vector of line-to-line voltages,” IEEE Trans. Power Electron., vol. 22, no. 5, pp. 1636–1648, Sep. 2007.
- [6] G. J. Yu, Y. S. Jung, J. Y. Choi, and G. S. Kim, “A novel two-mode MPPT control algorithm based on comparative study of existing algorithms,” Solar Energy, vol. 76, no. 4, pp. 455–463, 2004.
- [7] J. Gafford, M. Mazzola, J. Robbins, and G. Molen, “A multi-kilowatt high frequency ac-link inverter for conversion of low-voltage dc to utility power voltages,” in Proc. IEEE Power Electron. Spec. Conf., 2008, pp. 3707–3712.