

E-Cart System Based On Arm & Touch Panel for Easy Shopping



K. Srujana

B.Tech (EIE), M.Tech – (Embedded Systems)
Brilliant Institute of Engineering and Technology (BRIL)
Abdullapurment(V), Hayathnagar(M),
RR Dist -501505, India.



S. Naveen

B.TECH (ECE), MTECH (Embedded systems)
Brilliant Institute of Engineering and Technology (BRIL)
Abdullapurment(V), Hayathnagar(M),
RR Dist -501505, India.

Abstract:

Large supermarkets have a great variety of goods and prices. Different supermarkets may have different of commodity. It becomes difficulty for the customer to calculate the total amount of the goods he /she has purchased. It also makes wastage of time to the customer when calculating at cash counters. Some times over budget takes place which again need to remove the some goods. This not only causes consumers to waste a lot of time to search for goods. This paper proposes a new shopping guide system for large supermarkets based on wireless sensor network, which could overcome the defects of traditional supermarkets and greatly facilitate the consumer shopping needs. The design and implementation of a new intelligent shopping guide system for large supermarkets is presented in the article. The cart comprises of touch screen, RFID, and RF with ARM controller. The wireless touch screen integrated in the shopping cart can automatically broadcast the total fare of the selected goods at a time to the receiver side. The receiver section comprises of RF receiver which is interfaced with PC where the total fare of the particular cart get displayed. RFID reader collects number of goods collection periodically for billing. Thus, it overcomes lots of disadvantage in the traditional shopping guide system for supermarkets, such as inefficient management of commodities, wastage of time by standing in the line and inconvenient shopping.

Keywords: *Shopping Cart, RFID, Supermarkets, Shopping Guide, Business Process, Retail stores, Goods and Prices.*

Introduction:

Radio Frequency Identification (RFID) is one of the most exciting and promising technologies in the field of automated identification. Resource optimization, quality customer care, enhanced accuracy, and efficient business processes are the motivational factors behind the enormous use of RFID technology. In this paper, we present the design development and implementation of an automated future retail store based on RFID and touch screen technology. Large super markets have a great variety of goods and prices. Different super markets have different types of commodity. It becomes difficult for the customer to calculate the total number of goods he/she has purchased. It also makes wastage of time to the customers when calculating at cash counters.

OVERVIEW

It is a new advertisement and shopping guide system for large super markets based on wireless networks. The wireless touch panel is integrated in the shopping cart can automatically broadcast the commodities advertisements when the cart moving in RFID tags are given for the each product. So, when tag is placed near the reader, it takes information from the tag and sends the information to the controller. With the help of touch panel we can accept or reject the products. Zigbee transmitter and receiver are used for wireless

transmission. The goods which are selected will be automatically registered in pc of billing section. Now, no wastage of time in billing section. This system will be very easy for the customers as well as for the manpower.

AIM OF THE PROJECT

The objective of the project is reducing man power effort and saving time to the customers with hi-tech billing system.

It proposes a new advertisement and shopping guide system for large supermarkets based on wireless sensor network. The wireless touch panel integrated in the shopping cart can automatically broadcast the commodities advertisements when the cart moving in the large supermarket.

EXISTING AND PROPOSED SYSTEMS

EXISTING SYSTEM

At present situations, selection of goods based on price list, counting of goods, total calculation of the goods require more man power efforts and time. It elapse the highly valuable time of human. Customers will select the products and selected products will be dumped in the trolley and finally they will go for billing process. Here the customers should wait for hours together for billing purpose. It leads to waste of time.

PROPOSED SYSTEM

Consumers can easily search the commodity they need with the help of electronic guide service (led direction) and bar code or RFID reader collect number of goods collection periodically for billing. This is the easy way to purchase goods in any retail stores or large super markets. Here we will be using Radio Frequency Identification (RFID) technology, PIC microcontroller, Tarang module, LCD screen, RFID tags, RFID reader and Touch panel. With the help of all these equipment we are building a new system for easy assistance to customers. This will also make it easier for super markets during billing and check out.

BLOCK DIAGRAM TROLLY SECTION

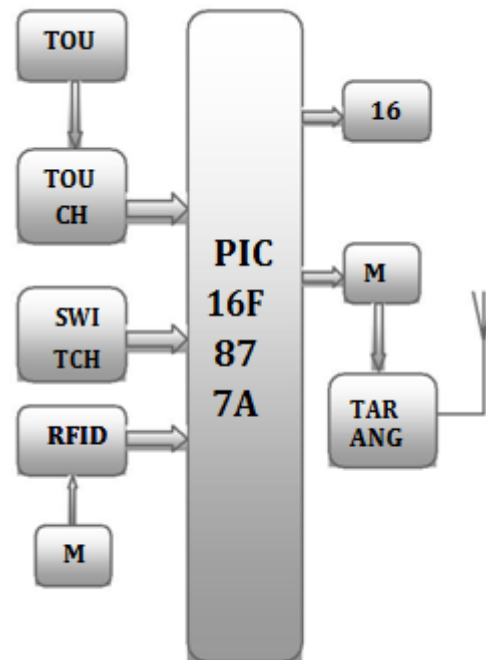

Fig 1.1 Block Diagram

BILLING SECTION PROJECT DESCRIPTION

The project is designed with PIC microcontroller, resistive touch panel, RFID module and wireless system. Here RFID, touch panel is interfaced with microcontroller through a relay and makes a serial communication. Wireless system such as tarang module is interfaced with serial port of microcontroller. The RFID and Touch panel is interfaced with RDO through relay. Hence when relay is OFF (NC+COM), RFID mode is enabled and when relay is ON (NO+COM), Touch mode is enabled. Here mode selection is done through two switches.



Fig 1.2 Receiver Side

The switches are interfaced with RD1 and RD2. When switch 1 (sw1=0) gives active low signal, the controller gives active low signal to the relay (relay=0). Hence COM will make continuity with NC. RFID module get ON as the module is interfaced with NC. If switch2 (SW2=0) gives active low signal, the controller gives active high signal to the relay (relay=1). Hence COM will make continuity with NO. Touch module get ON as the module is interfaced is accessed. It is showing cost of the product. Then switch2 is pressed to accept or reject or send all accessed products by touch panel. If send is pressed, the data is transmitted through zigbee and displayed on pc via serial communication.

CONCLUSION & FUTURE SCOPE

CONCLUSION

The project is developed with low cost, low power consumption. When the system is ready 5v is provided to microcontroller, RFID module, zigbee, touch panel controller etc. when switch1 is pressed RFID module selected and displaying to access the products(tags).When corrected product

FUTURE SCOPE

The proposed design is developed with simple devices. This system can improve by making more flexible to the shopping customers. Touch Screen with huge data base can make flexible. People does not require to search for a product. All the product information with number of items available, cost, route map to get the product. This facility makes more flexible to shoppers.

References:

- [1] C. Buragohain, D. Agrawal, and S. Suri. Distributed navigation algorithms for sensor networks. In IEEE INFOCOM, 2006.
- [2] J.Suryaprasad, B.O.P. Kumar, D. Roopa and A.K. Arjun, "A Novel Low-Cost Intelligent Shopping Cart", IEEE 2nd International Conference on Networked Embedded Systems for Enterprise Applications, pp.1-4, 2011.

[3] Parvathy A, Venkat Rohit Raj “ rfid based examination hall system”, a paper on IEEE paper.

[4] Kamran Ahasan,Paul Kingston IEEE paper on “rfid applications:an introductory and exploratory study”.

[5] Mingyan Li, Radha Poovendran, Rainer Falk paper on “multi-domain access control using asymmetric key based tag reader mutual authentication

[6] T. Dimitriou. A lightweight RFID protocol to protect against traceability and cloning attacks. In Conference on Security and Privacy for Emerging Areas in Communication Networks – SecureComm, Athens, Greece, September 2005. IEEE.

[7] A. Juels. RFID security and privacy: A research survey. IEEE Journal on Selected Areas in Computing, 24(2):381–394, February 2006.