

Development of Activation of Industrial Applications Using Arm7

**M.Arunajyothi**

Student,
Dept of ECE,

Mallareddy Engineering College for Women.

**M.Manju**

Asst prof,
Dept of ECE,

Mallareddy Engineering College for Women.

ABSTRACT:

Nowadays there are various electronic equipment available for remote operation of grid control. However, the main disadvantage of these systems is that they can be operated only from short ranges and also less reliable. Thus, to overcome the above drawbacks, we are using one of the wireless communication technique i.e., GSM (Global System for Mobile communications) is a digital cellular communications system which has rapidly gained acceptance and market share worldwide. The development of GSM is the first step towards a true personal communication system that will allow us to communicate anywhere, anytime and with anyone. GSM (Global Systems for Mobile Communication) is vastly used because of its simplicity in both transmitter and receiver design, can operate at 900 or 1800MHz band, faster, more reliable and globally network.

Keywords :

LPC2148controller,GSM, LCD, Triac.

I.INTRODUCTION:

The aim of the paper is to investigate a cost effective solution that will provide controlling of home appliances remotely and will also enable home security against intrusion in the absence of home owner. The motivation is to facilitate the users to automate their homes having ubiquitous access. The system provides availability due to development of a low cost system. The home appliances control system with an affordable cost was thought to be built that should be mobile providing remote access to the appliances and allowing home security.

Home security has been a major issue where crime is increasing and everybody wants to take proper measures to prevent intrusion. In addition there was a need to automate home so that user can take advantage of the technological advancement in such a way that a person getting off the office does not get melted with the hot climate. Therefore this paper proposes a system that allows user to be control home appliances ubiquitously and also provide security on detection of intrusion via SMS using GSM technology.

II.LITERATURE SURVEY:

Android Based Home Automation:

Remote operation is achieved by any smart-phone/Tablet etc., with Android OS, upon a GUI (Graphical User Interface) based touch screen operation. This project is based on the android application, android application sends command through Bluetooth. In this project we have an electrical load i.e fan and light that can be operated through triac using microcontroller. A DC motor is also connected through H-bridge this is to access the room door/ locker door from a distant place. In extension to the project in some Industries we have different types of loads at different locations. We can control all loads at a time from one place (control room) without connecting any physical wire between loads and control room. In this project we are using Bluetooth module for communication Android phone as our remote, controller, and some discrete components. The Bluetooth module is used here. Bluetooth is wireless technology standard for exchanging data over short distances (using short-wavelength radio waves in the ISM band from 2.4 to 2.485 GHz) from fixed and mobile devices, building personal area networks (PANs)

Conclusion:

Major draw back in this project is that this can be operated within short distance only.

Touch Screen based Home Automation System

The most common thing that he needs to do are switching ON/ OFF the loads without much human involvement wherever they are required by using wireless devices to control different appliances. The theme of this project is to control different loads. One such implementation is home Automation using touch screen. By touching digits in it, various appliances can be controlled automatically. A touch screen is used to control different loads. The project is built around the AT89S52 micro controller. A Triac Driver is used to drive the AC loads. By using a combination of MOC (OptoCoupler) 3021 and TRIAC (BT136) is used for Load driving.

Conclusion:

The major shortcomings of this project is that this is not wireless communication but this is simple and easy way to operate loads than the direct switches.

Radio Frequency Based Remote Industrial Appliances Control System:

In this project 433 MHz RF transmitter and receiver modules are used. These are ideal for remote control applications with low cost. The transmitter operates from 1.5-12V supply, making it ideal for battery-powered applications. The transmitter employs a SAW-stabilized oscillator, ensuring accurate frequency control for best range performance. The manufacturing-friendly SIP style package and low-cost make the STT-433 suitable for high volume applications.

Conclusion:

One of the biggest disadvantages to radio communication technology is the limited range of a radio signal. Even a powerful radio signal is only capable of reaching receivers within a specific geographic region, requiring that a vast network of radio stations be set up to communicate effectively to a large or spread-out group of receivers.

Proposed system:

This project is designed for seven power grids. Micro-controller is the heart of the project. A GSM modem is interfaced to microcontroller. This modem receives the messages from control mobile and sends as input to MCU. The MCU verify for authentication of the number and, if the number is authorized, grid control will be taken place, EEPROM is interfaced to this controller to save the grid position at every instant. This grid position information will not be deleted even in power failure conditions. 3X4 keypad is interfaced to change the mobile number at any time. 16X2 LCD is interfaced to display user-required information. In this project TRIAC is used as load controller (as a switch), MOC3021 used as a Triac driver. GSM network operators have roaming facilities, user can often continue to use there mobile phones when they travel to other countries etc....

This project uses regulated 3.3v, 750mA power supply. 7805 and 7812 three terminal voltage regulators are used for voltage regulation. Bridge type full wave rectifier is used to rectify the ac output of secondary of 230/12v step down transformer.

III.BLOCK DIAGRAM:

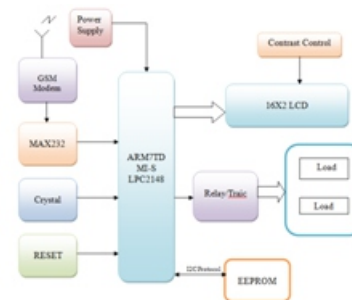

Modules involved in this project:

LPC2148 controller

The LPC2148 are based on a 16/32 bit ARM7TDMI-S™ CPU with real-time emulation and embedded trace support, together with 128/512 kilobytes of embedded high speed flash memory. A 128-bit wide memory interface and unique accelerator architecture enable 32-bit code execution at maximum clock rate. For critical code size applications, the alternative 16-bit Thumb Mode reduces code by more than 30% with minimal performance penalty.

With their compact 64 pin package, low power consumption, various 32-bit timers, 4- channel 10-bit ADC, USB PORT, PWM channels and 46 GPIO lines with up to 9 external interrupt pins these microcontrollers are particularly suitable for industrial control, medical systems, access control and point-of-sale. With a wide range of serial communications interfaces, they are also very well suited for communication gateways, protocol converters and embedded soft modems as well as many other general-purpose applications.

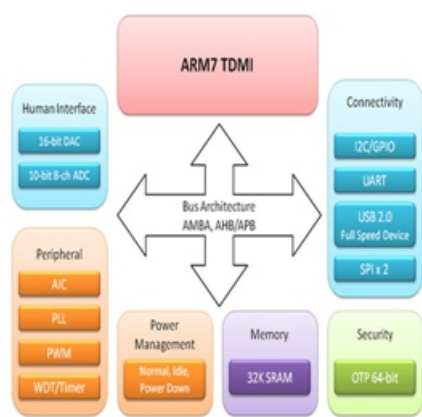

Global System for Mobile Communication (GSM)

Definition:

GSM, which stands for Global System for Mobile communications, reigns (important) as the world's most widely used cell phone technology. Cell phones use a cell phone service carrier's GSM network by searching for cell phone towers in the nearby area. Global system for mobile communication (GSM) is a globally accepted standard for digital cellular communication.

IV.MODEM SPECIFICATIONS:

The SIM300 is a complete Tri-band GSM solution in a compact plug-in module. Featuring an industry-standard interface, the SIM300 delivers GSM/GPRS900/1800/1900Mhz performance for voice, SMS, data and Fax in a small form factor and with low power consumption.

LCD:

LCD stands for Liquid Crystal Display. LCD is finding wide spread use replacing LEDs (seven segment LEDs or other multi segment LEDs) because of the following reasons:

- 1.The declining prices of LCDs.
- 2.The ability to display numbers, characters and graphics. This is in contrast to LEDs, which are limited to numbers and a few characters.
- 3.Incorporation of a refreshing controller into the LCD, thereby relieving the CPU of the task of refreshing the LCD. In contrast, the LED must be refreshed by the CPU to keep displaying the data.
- 4.Ease of programming for characters and graphics.

These components are "specialized" for being used with the microcontrollers, which means that they cannot be activated by standard IC circuits. They are used for writing different messages on a miniature LCD.



V.TRIAC:

TRIAC, from Triode for Alternating Current, is a genericized trade name for an electronic component which can conduct current in either direction when it is triggered (turned on), and is formally called a bidirectional triode thyristor or bilateral triode thyristor.



Working procedure:

- One need to make an SMS to the mobile number of the SIM placed in the GSM modem of the kit.
- Different loads connected to the kit can be on/off through simple SMS.
- Loads will be connected to the controller using Triac.
- This can be done from any remote place.
- LCD displays the information about the load.

VI. Conclusion:

This paper describes the design and development of a system for household appliance control using cell phone through global system for mobile communication (GSM) technology. The cellular communications is a potential solution for such remote controlling activities. SMS (short message service) technology can be used to control household appliances from distance. The proposed system makes use of wireless control hence can be effectively used in systems where unwired connections are desired. The system uses the user's mobile handset for control and therefore the system is more adaptable and cost-effective and also providing ubiquitous access for appliance control.

References :

1. Amit Chauhan, Reecha Ranjan Singh, Sangeeta Agrawal, Saurabh Kapoor, and S. Sharma, SMS based Remote Control System, International Journal of Computer Science and Management Studies, Vol. 11, pp 19-24, Issue 02, Aug 2011 .
2. E. Wong, A phone-based remote controller for home and office automation, IEEE Trans Consumer Electron., vol. 40, no. 1, pp. 28-33, Feb 1995
3. R. Das, S. Dutta, K. Samanta, A. Sarkar and D. Das, Security Based Domotics, International Conference On Computational Intelligence: Modeling, Techniques and Applications (CIMTA-2013), ELSEVIER (ISSN: 2212-0173)
4. S. Dutta, R. Das and A. Sarkar, Microcontroller Based Data Acquisition System, International Journal of Engineering and Technology, July edition 2013. (Paper Code-IJERTV2IS70678 with ISSN: 2278-0181)
5. Muhammad Ali Mazidi and Janice Gillispie Mazidi, The 8051 Microcontroller & Embedded System, Pearson Education India
6. Adamu Murtala Zungeru, Ufaruna Victoria Edu, and Ambafi James Garba, Design and Implementation of a Short Message Service Based Remote Controller, Computer Engineering and Intelligent Systems ISSN 2222-1719 (Paper) ISSN 2222-2863 (Online) Vol 3, No.4, 2012
7. A workshop on Atmega8 organized by Burdwan University in Sept., 2012
8. Robert, L. Boylestad and Nashelsky, L. (2002), Electronic devices and circuit theory, 8th edition, Prentice Hall (Pearson Education Inc.), 870-875
9. Richard. H. Barnett, Sarah Cox, and Larry O'Connell, Embedded C Programming and the Atmel AVR, 2nd Edition, Cengage Learning, 50-51