

Enhancement of power quality by using renewable source based STATCOM for wind power stations.

M.s V.Laxmi prasanna

M.Tech (Power Electronics)
Dhruva Institute and Technology
Nalgonda, Telangana 508252

Mr.V.Balu

Assistant Professor
Dhruva Institute and Technology
Nalgonda, Telangana 508252

Abstract:

A Power quality problem is an occurrence of nonstandard voltage, current or frequency that results in a failure or a misoperation of end user equipments. Utility distribution networks, sensitive industrial loads and critical commercial operations suffer from various types of outages and service interruptions which can cost significant financial losses. With the increase in load demand, the Renewable Energy Sources (RES) are increasingly connected in the distribution systems which utilizes power electronic Converters/Inverters in cups (custom power devices). This paper presents novel power electronics for the integration of wind and photovoltaic (PV) control strategy for achieving maximum benefits from these grid-interfacing inverters using cascaded current-voltage control strategy is proposed for inverters to simultaneously improve the power quality of the inverter local load voltage and the current exchanged with the grid.

INTRODUCTION

To have sustainable growth and social progress, it successfully operating all over the world. In the fixed is necessary to meet the energy need by utilizing the speed wind turbine operation, all the fluctuation in the renewable energy resources like wind, biomass, hydro, co- wind speed are transmitted as fluctuations in the generation, etc In sustainable energy system, energy mechanical torque, electrical power on the grid and leads conservation and the use of renewable source are the key to large voltage fluctuations. During the normal operation, paradigm. The need to integrate the renewable energy like wind turbine produces continuous variable output wind energy into

power system is to make it possible to power. These power variations are mainly caused by the minimize the environmental impact on conventional plant effect of turbulence, wind shear and tower-shadow and of [1]. The integration of wind energy into existing power control system in the power system.

Thus, the network system presents a technical challenges and that requires needs to manage for such fluctuations. The power quality consideration of voltage regulation, stability, power issues can be viewed with respect to the wind generation, quality problems. The power quality is an essential transmission and distribution network, such as voltage customer-focused measure and is greatly affected by the sag, swells, flickers, harmonics etc.

However the wind operation of a distribution and transmission network. generator introduces disturbances into the distribution The issue of power quality is of great importance to the network. One of the simple methods of running a wind turbine [2]. There has been an extensive growth and generating system is to use the induction generator quick development in the exploitation of wind energy in connected directly to the grid system. The induction recent years. The individual units can be of large capacity generator has inherent advantages of cost up to 2 MW, feeding into distribution network, effectiveness and robustness. However; induction generators require reactive power for magnetization. When from the wind velocity and generator torque. The voltage the generated active power of an induction generator is varied due to wind, absorbed reactive power and terminal voltage of an induction



generator can be significantly affected. In the event of increasing grid disturbance, a battery energy storage system for wind energy generating system is generally required to compensate the fluctuation generated by wind turbine. A STATCOM based control technology has been proposed for improving the power quality which can technically manages the power level associates with the commercial wind turbines. The proposed STATCOM control scheme for grid connected wind energy generation for power quality improvement has following objectives. Unity power factor at the source side. Reactive power support only from STATCOM to wind Generator and Load. Simple bang-bang controller for STATCOM to achieve fast dynamic response. The Increasing number of renewable energy sources and distributed generators requires new strategies for the operation and management of the electricity grid in order to maintain or even to improve the power-supply reliability and quality. In addition, liberalization of the grids leads to new management structures, in which trading of energy and power is becoming increasingly important. The power-electronic technology plays an important role in distributed generation and in integration of renewable energy sources into the electrical grid, and it is widely used and rapidly expanding as these applications become more integrated with the grid-based systems. During the last few years, power electronics has undergone a fast evolution, which is mainly due to two factors. The first one is the development of fast semiconductor switches that are capable of switching quickly and handling high powers. The second factor is the introduction of real-time computer controllers that can implement advanced and complex control algorithms. These factors together have led to the development of cost-effective and grid-friendly converters. In this paper, new trends in power-electronic technology for the integration of renewable energy sources and energy-storage systems are presented. This paper is organized as follows.

In Section II, we describe the current technology and future trends in variable-speed wind turbines. Wind energy has been demonstrated to be both technically

and economically viable. It is expected that current developments in gearless energy transmission with power-electronic grid interface will lead to a new generation of quiet, efficient, and economical wind turbines. In Section III, we present power-conditioning systems used in grid-connected photovoltaic (PV) generation plants. The continuously decreasing prices for the PV modules lead to the increasing importance of cost reduction of the specific PV converters. Energy storage in an electricity generation and supply system enables the decoupling of electricity generation from demand.

In other words, the electricity that can be produced at times of either low-demand low-generation cost or from intermittent renewable energy sources is shifted in time for release at times of high-demand high-generation cost or when no other generation is available. Appropriate integration of renewable energy sources with storage systems allows for a greater market penetration and results in primary energy and emission savings. In Section IV, we present research and development trends in energy-storage systems used for the grid integration of intermittent renewable energy sources.

PV TECHNOLOGY

This section focuses on the review of the recent developments of power-electronic converters and the state of the art of the implemented PV systems. PV systems as an alternative energy resource or an energy-resource complementary in hybrid systems have been becoming feasible due to the increase of research and development work in this area. In order to maximize the success of the PV systems, a high reliability, a reasonable cost, and a user-friendly design must be achieved in the proposed PV topologies. Several standards given by the utility companies must be obeyed in the PV-module connection. Nowadays, the standards EN61000-3-2, IEEE1547, and the U.S. National Electrical Code (NEC) 690, and the future international standard (still a Committee Draft for Vote- CDV) IEC61727 are being considered. These standards deal with issues like power quality, detection of islanding

operation, grounding, etc. They define the structure and the features of the present and future PV modules.

A. Market Considerations

Solar-electric-energy demand has grown consistently by 20%–25% per annum over the past 20 years, which is mainly due to the decreasing costs and prices. This decline has been driven by

- 1) an increasing efficiency of solar cells;
- 2) manufacturing-technology improvements; and
- 3) economies of scale.

In 2001, 350 MW of solar equipment was sold to add to the solar equipment already generating a clean energy. In 2003, 574 MW of PV was installed. This increased to 927 MW in 2004. The European Union is on track to fulfilling its own target of 3 GW of renewable electricity from PV sources for 2010, and in Japan, the target is 4.8 GW. If the growth rates of the installation of PV systems between 2001 and 2003 could be maintained in the next years, the target of the European Commission's White Paper for a Community Strategy and Action Plan on Renewable Sources of Energy would already be achieved in 2008. It is important to notice that the PV installation growth-rate curve in the European Union exactly mirrors that of wind power, with a delay of approximately 12 years. This fact predicts a great future for PV systems in the coming years.

B. Design of PV-Converter Families

An overview of some existing power inverter topologies for interfacing PV modules to the grid is presented. The approaches are further discussed and evaluated in order to recognize the most suitable topologies for future PV converters, and, finally, a conclusion is given. Due to advances in transistor technology, the inverter topologies have changed from large thyristor-equipped grid connected inverters to smaller IGBT-equipped ones. These transistors permit to increase the power switching frequency in order to extract more energy and fulfill the connecting standards. One requirement of standards is that the inverters must also be able to

detect an islanding situation and take appropriate measures in order to protect persons and equipment. In his situation, the grid has been removed from the inverter, which then only supplies local loads. This can be troublesome for many high-power transformer less systems, since a single phase inverter with a neutral-to-line grid connection is a system grounded on the grid side. In general, PV cells can be connected to the grid (grid connection application), or they can be used as isolated power supplies. Several classifications of converter topologies can be done with respect to the number of power processing stages, location of power-decoupling capacitors, use of transformers, and types of grid interface. However, before discussing PV converter topologies, three designs of inverter families are defined: central inverters, module-oriented or module-integrated inverters, and string inverters. The central converters connect in parallel and/or in series on the dc side. One converter is used for the entire PV plant (often divided into several units organized in master–slave mode). The nominal power of this topology is up to several megawatts. The module-oriented converters with several modules usually connect in series on the dc side and in parallel on the ac side. The nominal power ratings of such PV power plants are up to several megawatts. In addition, in the module-integrated converter topology, one converter per PV module and a parallel connection on the ac side are used. In this topology, a central measure for main supervision is necessary. Although this topology optimizes the energy yield, it has a lower efficiency than the string inverter. This concept can be implemented for PV plants of about 50–100 W. The multistring topology permits the integration of PV strings of different technologies and orientations (north, south, east, and west).

C. PV Topologies

Conventionally, a classification of PV topologies is divided into two major categories: PV inverters with dc/dc converter (with or without isolation) and PV inverters without dc/dc converter (with or without isolation). The isolation used in both categories is acquired using a transformer that can be placed on

either the grid or low frequency (LF) side or on the HF side. The line-frequency transformer is an important component in the system due to its size, weight, and price. The HF transformer is more compact, but special attention must be paid to reduce losses. The use of a transformer leads to the necessary isolation (requirement in U.S.), and modern inverters tend to use an HF transformer. However, PV inverters with a dc/dc converter without isolation are usually implemented in some countries where grid-isolation is not mandatory. Basic designs focused on solutions for HF dc/dc converter topologies with isolation such as full-bridge or single-inductor push-pull permit to reduce the transformer ratio providing a higher efficiency together with a smoother input current. However, a transformer with tap point is required. In addition, a double-inductor push-pull is implemented in other kind of applications (equivalent with two interleaved boost converters leading to a lower ripple in the input current), but extra inductor is needed. A full-bridge converter is usually used at power levels above 750 W due to its good transformer utilization. Another possible classification of PV inverter topologies can be based on the number of cascade power processing stages. The single-stage inverter must handle all tasks such as maximum-power-point-tracking (MPPT) control, grid-current control, and voltage amplification. This configuration, which is useful for a centralized inverter, has some drawbacks because it must be designed to achieve a peak power of twice the nominal power. Another possibility is to use a dual-stage inverter. In this case, the dc/dc converter performs the MPPT (and perhaps voltage amplification), and the dc/ac inverter is dedicated to control the grid current by means of pulse width modulation (PWM), space vector modulation (SVM), or bang-bang operation. Finally, multistage inverters can be used, as mentioned above. In this case, the task for each dc/dc converter is MPPT and, normally, the increase of the dc voltage. The dc/dc converters are connected to the dc link of a common dc/ac inverter, which takes care for the grid-current control. This is beneficial since a better control of each PV module/string is achieved, and that common dc/ac

inverter may be based on a standard variable speed-drive (VSD) technology. There is no any standard PV inverter topology. Several useful proposed topologies have been presented, and some good studies regarding current PV inverters have been done. The current control scheme is mainly used in PV inverter applications. In these converters, the current into the stage is modulated/controlled to follow a rectified sinusoidal waveform, and the task for the circuit is simply to recreate the sine wave and inject it into the grid. The circuits apply zero voltage switching (ZVS) and zero-current switching (ZCS). Thus, only conduction losses of the semiconductors remain. If the converter has several stages, power decoupling must be achieved with a capacitor in parallel with the PV module(s). The current control scheme is employed more frequently because a high-power factor can be obtained with simple control circuits, and transient current suppression is possible when disturbances such as voltage changes occur in the utility power system. In the current control scheme, operation as an isolated power source is difficult, but there are no problems with grid interconnection operation.

D. Future Trends

The increasing interest and steadily growing number of investors in solar energy stimulated research that resulted in the development of very efficient PV cells, leading to universal implementations in isolated locations. Due to the improvement of roofing PV systems, residential neighborhoods are becoming a target of solar panels, and some current projects involve installation and setup of PV modules in high building structures. PV systems without transformers would be the most suitable option in order to minimize the cost of the total system. On the other hand, the cost of the grid-connected inverter is becoming more visible in the total system price. A cost reduction per inverter watt is, therefore, important to make PV-generated power more attractive. Therefore, it seems that centralized converters would be a good option for PV systems. However problems associated with the centralized control appear, and it can be difficult to use this type

of systems. An increasing interest is being focused on ac modules that implement MPPT for PV modules improving the total system efficiency. The future of this type of topologies is to develop “plug and play systems” that are easy to install for non expert users. This means that new ac modules may see the light in the future, and they would be the future trend in this type of technology. The inverters must guarantee that the PV module is operated at the maximum power point (MPP) owing to use MPPT control increasing the PV systems efficiency. The operation around the MPP without too much fluctuation will reduce the ripple at the terminals of the PV module. Therefore, the control topics such as improvements of MPPT control, THD improvements, and reduction of current or voltage ripples will be the focus of researchers in the years to come . These topics have been deeply studied during the last years, but some improvements still can be done using new topologies such as multilevel converters.

Power Quality Standards, Issues And it's Consequences International Electro Technical Commission Guidelines:

The guidelines are provided for measurement of power quality of wind turbine. The International standards are developed by the working group of Technical Committee- 88 of the International Electro-technical Commission (IEC)[15], IEC standard 61400-21, describes the procedure for determining the power quality characteristics of the wind turbine [4-10]. The standard norms are specified. IEC 61400-21: Wind turbine generating system, part-21.Measurement and Assessment of Power quality characteristic of grid connected wind Turbine. IEC 61400-13: Wind Turbine—measuring procedure in determining the power behavior. IEC 61400-3-7: Assessment of emission limit for Fluctuating load IEC 61400-12: Wind Turbine Performance. The data sheet with electrical characteristic of wind turbine provides the base for the utility assessment regarding a grid connection.

Voltage Variation: The voltage variation issue results variation is directly related to real and reactive power variations. The voltage variation is commonly classified as under:

- Voltage Sag/Voltage Dips.
- Voltage Swells.
- Short Interruptions.
- Long duration voltage variation.

The voltage flicker issue describes dynamic variations in the network caused by wind turbine or by varying loads. Thus the power fluctuation from wind turbine occurs during continuous operation. The amplitude of voltage fluctuation depends on grid strength, network impedance and phase-angle and power factor of the wind turbines. It is defined as a fluctuation of voltage in a frequency 10–35 Hz. The IEC 61400-4-15 specifies a flicker meter that can be used to measure flicker directly.

Harmonics: The harmonic results due to the operation of power electronic converters. The harmonic voltage and current should be limited to the acceptable level at the point of wind turbine connection to the network.

To ensure the harmonic voltage within limit, each source of harmonic current can allow only a limited contribution , as per the IEC-61400-36 guideline. The rapid switching gives a large reduction in lower order harmonic current compared to the line commutated converter, but the output current will have high frequency current and can be easily filter-out.

Wind Turbine Location in Power System: The way of connecting the wind generating system into the power system highly influences the power quality. Thus the operation and its influence on power system depend on the structure of the adjoining power network.

Self Excitation of Wind Turbine Generating System: The self excitation of wind turbine generating system (WTGS) with an asynchronous generator takes place after disconnection of wind turbine generating system (WTGS) With local load.

The risk of self excitation arises especially when WTGS is equipped with compensating capacitor. The capacitor connected to induction generator provides reactive power compensation. However the voltage and frequency are determined by the balancing of the system. The disadvantages of self excitation are the safety aspect and balance between real and reactive power [5].

GRID COORDINATION RULE American Wind Energy Association (AWEA) led the effort to develop its own grid code for stable operation as per IEC-61400-21 for the interconnection of wind plants to the utility systems, after the block out in United State in August 2003. According to these, operator of transmission grid is responsible for the organization and operation of interconnected system.

1) **Voltage rise (u)** The voltage rise at the point of common coupling can be approximated as a function of maximum apparent power S_{max} of the turbine, the grid impedances R and X at the point of common coupling and the phase angle, given in Eq. 1.

$$\Delta u = \frac{S_{max} (R \cos \phi - X \sin \phi)}{u^2} \quad (1)$$

Where Δu —voltage rise,

S_{max} —max. apparent power,

ϕ —phase difference,

U —nominal voltage of grid.

The Limiting voltage rise value is <2 %

2) **Voltage dips (d)** The voltage dips is due to startup of wind turbine and it causes a sudden reduction of voltage. It is the relative % voltage change due to switching operation of win turbine. The decrease of nominal voltage change is given in Eq. 2.

$$D = K_u s_n / s_k \quad (2)$$

Where d is relative voltage change, s_n is rated apparent power, s_k is short circuit apparent power, and K_u is sudden voltage reduction factor. The acceptable voltage dips limiting value is <3%.

3) **Flicker** The measurements are made for maximum number of specified switching operation of wind turbine with 10- min period and 2-h period are specified, as given in Eq. 3.

$$P_u = c (\psi_k) s_n / s_k \quad (3)$$

Where P_u —Long term flicker.

$c (\psi_k)$ —Flicker coefficient The Limiting Value for flicker coefficient is about ≤ 0.4 , for average time of 2 h.

4) **Harmonics** The harmonic distortion is assessed for variable speed turbine with a electronic power converter at the point of common connection. The total harmonic voltage distortion of voltage is given as in Eq. 4.

$$V_{THD} = \sqrt{\sum_{h=2}^{40} \frac{V_n^2}{V_1^2}} 100 \quad (4)$$

Where V_n is the n th harmonic voltage and V_1 is the fundamental frequency (50) Hz.

The THD limit for 132 KV is < 3%.

$$I_{THD} = \sqrt{\sum \frac{I_n}{I_1}} 100 \quad (5)$$

5) **GRID FREQUENCY** The grid frequency in India is specified in the range of 47.5–51.5 Hz, for wind farm connection.

TOPOLOGY FOR POWER QUALITY IMPROVEMENT

The STATCOM based current control voltage source inverter injects the current into the grid will cancel out the reactive part and harmonic part of the load and induction generator current, thus it improves the power factor and the power quality. To accomplish these goals, the grid voltages are sensed and are

synchronized in generating the current. The proposed grid connected system is implemented for power

A.WIND ENERGY GENERATING SYSTEM: In this configuration, wind generations are based on constant speed topologies with pitch control turbine. The induction generator is used in the proposed scheme because of its simplicity, it does not require a separate field circuit, it can accept constant and variable loads, and has natural protection against short circuit. The available power of wind energy system is presented as under in Eq.6..

$$P_{wind} = \frac{1}{2} \rho A V_{wind}^3 \quad (6)$$

Where ρ (kg/m) is the air density and A (m) is the area swept out by turbine blade, V wind is the wind speed in mtr/s. It is not possible to extract all kinetic energy of wind, thus it extract a fraction of power in wind, called power coefficient C_p of the wind turbine, and is given in Eq.

$$P_{mech} = C_p P_{wind} \quad (7)$$

Where C_p is the power coefficient, depends on type and operating condition of wind turbine. This coefficient can be express as a function of tip speed ratio γ and θ pitch angle. The mechanical power produce by wind turbine is given in Eq. 8.

$$P_{mech} = \frac{1}{2} \rho \pi R^2 V_{wind}^3 C_p \quad (8)$$

Where R is the radius of the blade (m).

B.STATCOM – STATIC SYNCHRONOUS COMPENSATOR The STATCOM (or SSC) is a shunt-connected reactive-power compensation device that is capable of generating and/ or absorbing reactive power and in which the output can be varied to control the specific parameters of an electric power system. In general it is solid state switching converter which is capable of generating or absorbing independently controllable real and reactive power at its output terminals when it is fed from an energy source at its input terminals. Specifically, the STATCOM considered in this is a voltage-source converter from a given input of dc voltage produces a set of 3-phase ac-output voltages, each in phase with

quality improvement at point of common coupling (PCC), for grid connected system in Fig. 1 and coupled to the corresponding ac system voltage through leakage reactance. The dc voltage is provided by an energy-storage capacitor.

A STATCOM can improve power-system performance in such areas as the following: 1. The dynamic voltage control in Transmission and distribution systems; 2. The power-oscillation damping in power transmission systems; 3. The transient stability; 4. The voltage flicker control; and 5. It also controls real power in line when it is needed. Advantages

- 1) It occupies small areas.
- 2) It replaces the large passive banks and circuit elements by compact converters.
- 3) Reduces site work and time.
- 4) Its response is very fast.

BESS-STATCOM: The battery energy storage system (BESS) is used as an energy storage element for the purpose of voltage regulation. The BESS will naturally maintain dc capacitor voltage constant and is best suited in STATCOM since it rapidly injects or absorbed reactive power to stabilize the grid system. It also control the distribution and transmission system in a very fast rate. When power fluctuation occurs in the system, the BESS can be used to level the power fluctuation by charging and discharging operation. The battery is connected in parallel to the dc capacitor of STATCOM.

The STATCOM is a three-phase voltage source inverter having the capacitance on its DC link and connected at the point of common coupling. The STATCOM injects a compensating current of variable magnitude and frequency component at the bus of common coupling.

System Operation: The shunt connected STATCOM with battery energy storage is connected with the interface of the induction generator and non-linear load at the PCC in the grid system. The STATCOM compensator output is varied according to the

controlled strategy, so as to maintain the power quality norms in the grid system. The current control strategy is included in the control.

VI. SYSTEM PERFORMANCE

The proposed control scheme is simulated using SIMULINK in power system block set. The system parameter for given system is given Table I. The system performance of proposed system under dynamic condition is also presented.

A. Voltage Source Current Control—Inverter Operation

The three phase injected current into the grid from STATCOM will cancel out the distortion caused by the nonlinear load and wind generator. The IGBT based three-phase inverter is connected to grid through the transformer. The generation of switching signals from reference current is simulated within hysteresis band of 0.08. The choice of narrow hysteresis band switching in the system improves the current quality. The control signal of switching frequency within its operating band, as shown in Fig. 4. The choice of the current band depends on the operating voltage and the interfacing transformer impedance. The compensated current for the nonlinear load and demanded reactive power is provided by the inverter. The real power transfer form the battery is also supported by the controller of this inverter. The three phase inverter injected current are shown in Fig. 5.

TABLE I
SYSTEM PARAMETERS

S.N.	Parameters	Ratings
1	Grid Voltage	3-phase ,415V,50 Hz
2	Induction Motor/Generator	3.35 kVA,415V, 50 Hz, P = 4, Speed = 1440 rpm, Rs = 0.01Ω, Rr=0.015Ω,Ls =0.06H,Lr=0.06H
3	Line Series Inductance	0.05mH
4	Inverter Parameters	DC Link Voltage = 800V, DC link Capacitance = 100 μF. Switching frequency = 2 kHz.
5	IGBT Rating	Collector Voltage =1200V, Forward Current =50A,Gate voltage =20V, Power dissipation = 310W
6	Load Parameter	Non-linear Load 25kW.

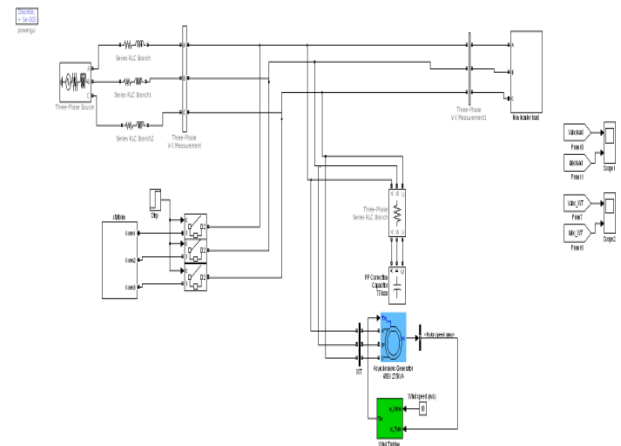

Fig 1.conventional simulation circuit Grid connected system for power quality improvement.

B. STATCOM—Performance Under Load Variations

The wind energy generating system is connected with grid having the nonlinear load. The performance of the system is measured by switching the STATCOM at time s in the system and how the STATCOM responds to the step change command for increase in additional load at 1.0 s is shown in the simulation. When STATCOM controller is made ON, without change in any other load condition parameters, it starts to mitigate for reactive demand as well as harmonic current.

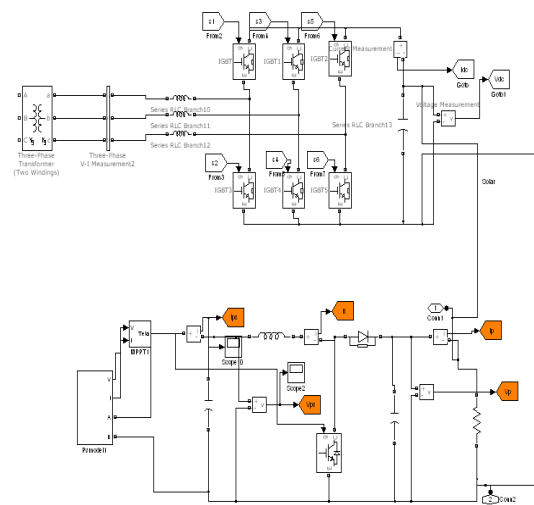

Fig 2.proposed simulation circuit PV grid connected system for power quality improvement

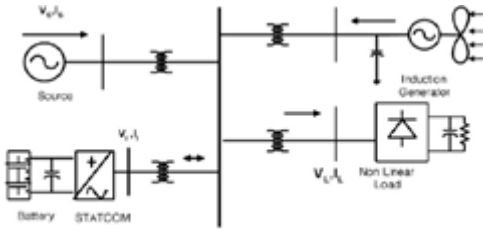

Fig. 3. Grid connected system for power quality improvement.

The dynamic performance is also carried out by step change in a load, when applied at 1.0 s. This additional demand is fulfilled by STATCOM compensator. Thus, STATCOM can regulate the available real power from source. The result of source current, load current are shown in Fig. 6(a) and (b) respectively. While the result of injected current from STATCOM are shown in Fig. 6(c) and the generated current from wind generator at PCC are depicted in Fig. 6(d).

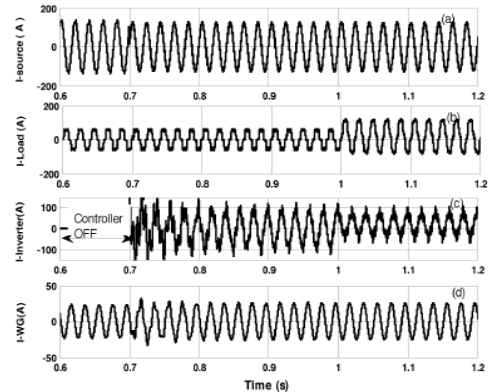
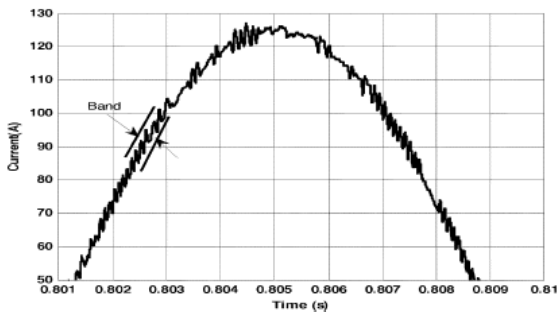

Fig. 6. (a) Source Current. (b) Load Current. (c) Inverter Injected Current. (d) Wind generator (Induction generator) current.

The DC link voltage regulates the source current in the grid system, so the DC link voltage is maintained constant across the capacitor as shown in Fig. 7(a). The current through the dc link capacitor indicating the charging and discharging operation as shown in Fig. 7(b)



fi Fig. 4. Switching signal within a control hysteresis band.

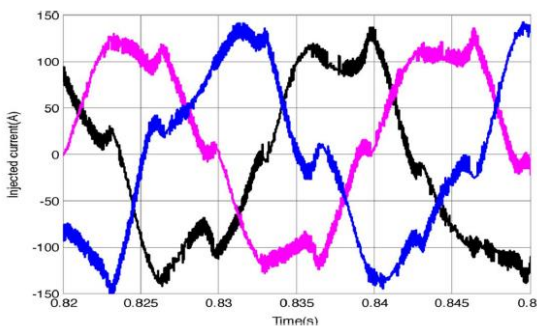

Fig. 5. Three phase injected inverter Current.

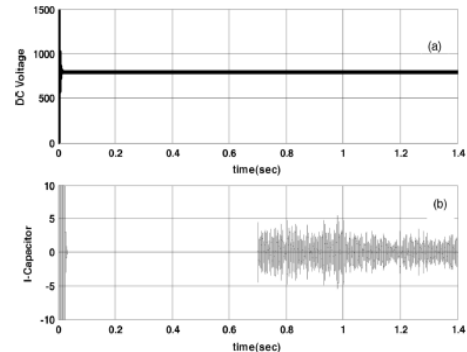

Fig. 7. (a) DC link voltage. (b) Current through Capacitor.

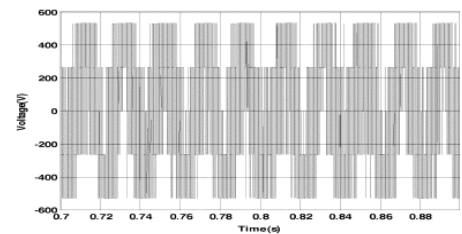

Fig. 8. STATCOM output voltage.

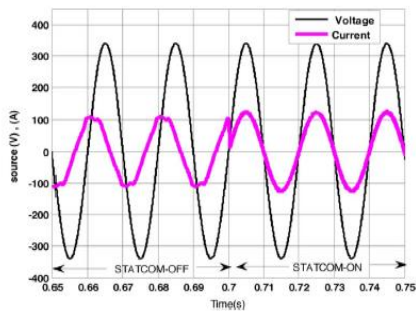

Fig. 9. Supply Voltage and Current at PCC.

A. Power Quality Improvement

It is observed that the source current on the grid is affected due to the effects of nonlinear load and wind generator, thus purity of waveform may be lost on both sides in the system. The inverter output voltage under STATCOM operation with load variation is shown in Fig. 8. The dynamic load does affect the inverter output voltage. The source current with and without STATCOM operation is shown in Fig. 9. This shows that the unity power factor is maintained for the source power when the STATCOM is in operation.

VII. CONCLUSION

The paper presents the STATCOM-based control scheme for power quality improvement in grid connected wind generating system and with non linear load. The power quality issues and its consequences on the consumer and electric utility are presented. The operation of the control system developed for the STATCOM-BESS in MATLAB/SIMULINK for maintaining the power quality is simulated. It has a capability to cancel out the harmonic parts of the load current. It maintains the source voltage and current in-phase and support the reactive power demand for the wind generator and load at PCC in the grid system, thus it gives an opportunity to enhance the utilization factor of transmission line. The integrated wind generation and STATCOM with BESS have shown the outstanding performance.

REFERENCES

- [1] A. Sannino, "Global power systems for sustainable development," in *IEEE General Meeting*, Denver, CO, Jun. 2004.
- [2] K. S. Hook, Y. Liu, and S. Atcitty, "Mitigation of the wind generation integration related power quality issues by energy storage," *EPQU J.*, vol. XII, no. 2, 2006.
- [3] R. Billinton and Y. Gao, "Energy conversion system models for adequacy assessment of generating systems incorporating wind energy," *IEEE Trans. on E. Conv.*, vol. 23, no. 1, pp. 163–169, 2008, Multistate.
- [4] *Wind Turbine Generating System—Part 21*, International standard-IEC61400-21, 2001.
- [5] J. Manel, "Power electronic system for grid integration of renewable energy source: A survey," *IEEE Trans. Ind. Electron.*, vol. 53, no. 4, pp. 1002–1014, 2006, Carrasco.
- [6] M. Tsili and S. Papathanassiou, "A review of grid code technology requirements for wind turbine," *Proc. IET Renew. power gen.*, vol. 3, pp. 308–332, 2009.
- [7] S. Heier, *Grid Integration of Wind Energy Conversions*. Hoboken, NJ: Wiley, 2007, pp. 256–259.
- [8] J. J. Gutierrez, J. Ruiz, L. Leturiondo, and A. Lazkano, "Flicker measurement system for wind turbine certification," *IEEE Trans. Instrum. Meas.*, vol. 58, no. 2, pp. 375–382, Feb. 2009.
- [9] Indian Wind Grid Code Draft report on, Jul. 2009, pp. 15–18, C-NET.

Author(s) Details:



M.s V.Laxmi prasanna. She is pursuing M.Tech (Power Electronics) at Dhruva institute and



ISSN No: 2348-4845

International Journal & Magazine of Engineering, Technology, Management and Research

A Peer Reviewed Open Access International Journal

technology . Completed her B.Tech(EEE) from
Ramanandha thirtha Engineering collage
Nalgonda, TELANGANA STATE,INDIA



Mr.V.BALU he received M.E (Power Systems) from
University College of Engineering, Osmania
University, Hyderabad in 2008 A.P. Graduated from
JNTU University, Hyderabad in the year 2002.
Presently he is working as Assistant Professor in
Dhruva Institute of Engineering & Technology,
Hyderabad in the Department of Electrical &
Electronics Engineering. He had total 9 years of
experience in teaching. His fields of interest include
power quality and Power Systems Optimization.