

## Efficient Layout Design and Simulation of CMOS Multiplexer by Using Different Technologies

**MD Farooq Pasha**

M.Tech- VLSI,  
Department of ECE,  
VIF College of  
Engineering and  
Technology, Hyderabad,  
Telangana, India.

**B.kotesh**

Assistant Professor,  
Department of ECE,  
VIF College of  
Engineering and  
Technology, Hyderabad,  
Telangana, India.

**Imthiazunnisa Begum**

HOD,  
Department of ECE,  
VIF College of  
Engineering &  
Technology, Hyderabad,  
Telangana, India.

**MD Abid Hussain**

Assistant Professor,  
Department of ECE  
VIF College of  
Engineering and  
Technology, Hyderabad,  
Telangana, India.

### Abstract:

In this paper, a multiplexer has been designed and layout simulated using 90nm in Auto generated and semicustom design mode. The schematic of 4:1 multiplexer has been designed using and its equivalent layout is created using micro wind tools. The Performance has been analyzed and compared in terms of area and power. It can be observed from simulated results in semicustom that 75% reduction in area and 6.6% reduction in power

### 1. INTRODUCTION:

The VLSI (Very large scale integration) is an important tool to integrate the number of components on a single chip. The choice of design style of VLSI product depends on the performance requirement, the technology being used, the lifetime and cost of the project. [1] The important factors are area reduction, minimum power consumption and high speed. Now days, the demand for these factors are increasing. There are many design techniques are developed to enhance the performance of logic circuits. [2] The operation in high temperature environment results in silicon failure and the circuit will be damaged. So, the requirement for low power consumption is increasing with the growth in devices like Mobile phones, medical instruments and PCs.

Another factor is power consumption, which should be minimized because it results in low electricity consumption and less amount of heat is produced. [3] Multiplexer is major component in telecom industry and it's a key component of any arithmetic circuit. These are building blocks for data switching structure with resource sharing. In a communication system, the transmission takes place between transmitter and receiver by using a multiplexer at the transmitter side to transmit the data from many users on a single channel with the help of selection (control) lines.[4]

### 2. MULTIPLEXER:

Multiplexer is a combinational logic circuit, in which the output is generated from one of the various inputs. Multiplexer is abbreviated as MUX. A practical application in which many users are requested to use a single channel to send their data, in that case multiplexer has ability to multiplex all signals and transmit on a single channel. So, it also called a data selector, to select the number of inputs one by one to provide a single output. The selection lines control routing of data input to the output.

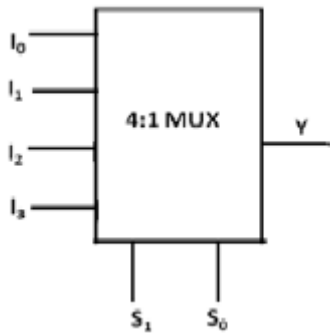

**Fig1- 4:1 MUX**

The 4:1 MUX consists of 4 external inputs with two selected lines to provide single output. An intelligent multiplexer is referred to concentrator in the telecom world. Multiplexers are used for switching application, A/D convertor, telephone network and Digital semiconductors. [5] Multiplexers can be used as programmable logic devices. The circuit is combining two or more digital signals to give a single line. [6]

**Table 1- 4:1 MUX truth table**

Selection lines		Output
S <sub>1</sub>	S <sub>0</sub>	Y
0	0	I <sub>0</sub>
0	1	I <sub>1</sub>
1	0	I <sub>2</sub>
1	1	I <sub>3</sub>

The above table (1) shows the truth table for 4:1 MUX which consists of 4 combinations of input.

By using,  $(4 = 2^2)$  2 selection lines are required to design 4:1 Multiplexer. Boolean expression for 4:1 MUX is written as:-

$$Y = I_0 S_1 S_0 + I_1 S_1 \bar{S}_0 + I_2 \bar{S}_1 S_0 + I_3 \bar{S}_1 \bar{S}_0$$

are the inputs applied to multiplexer, S<sub>0</sub> and S<sub>1</sub> are selection lines, Y is the output of the multiplexer

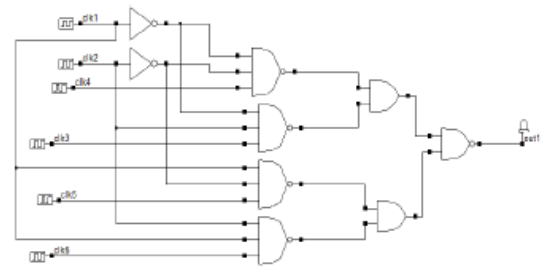

**Fig2- 4:1 MUX Schematic**

In above Schematic, clock are used to provide input and LEDs (light emitting diode) to test the output. For hardware implementation, it requires four 3-input NAND gate and a 4-input NAND gate with two inverters to generate the complement of S<sub>1</sub> and S<sub>0</sub>.

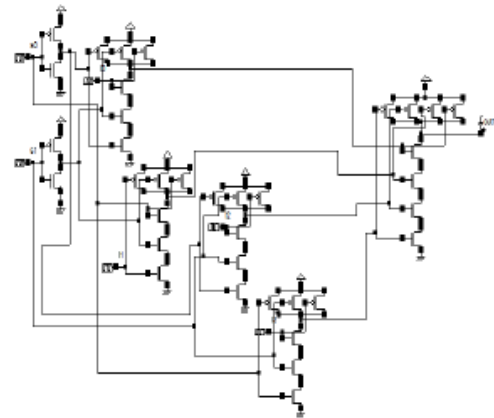

**Fig.3- 4:1 MUX using CMOS**

The circuit can also build with CMOS technology. It has been designed with implementing PMOS & NMOS transistors. In CMOS circuit, there is low power dissipation during switching operation of the device. The PMOS & NMOS transistors form the pull up and pull down network respectively. It is made by combining of NMOS and PMOS transistors with four external inputs (I<sub>0</sub>, I<sub>1</sub>, I<sub>2</sub>, I<sub>3</sub>) and normal & complemented inputs of S<sub>1</sub> and S<sub>0</sub> as selection lines to provide single output. [7]

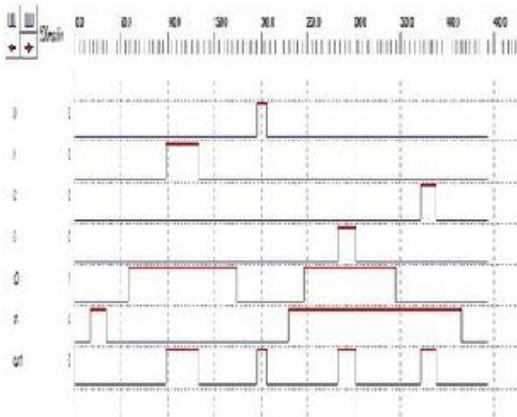
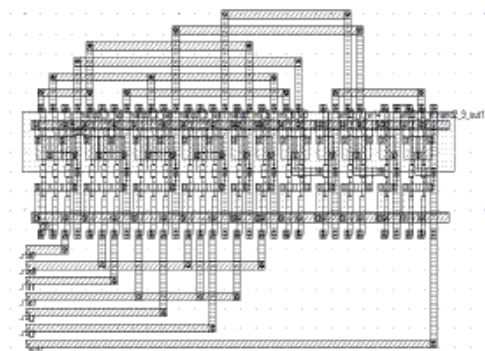

**Fig.4- 4:1 MUX output**

The above waveform is of 4:1 multiplexer, generated in DSCH in which s1 & s0 are control lines, (i0, i1, i2, i3) are input and out1 is output.

**3. LAYOUT DESIGN:**

DSCH3 & Micro wind are the CAD tools have been used to implement 4:1 MUX using NAND gate. Before the layout of 4:1 MUX, the schematic of circuit must be validate. The solution of this problem is taken by Dsch & micro wind. Dsch is a simulator for the simulation of logic design and to understand the proper function of the circuit. Then, the layout is created in micro wind. [8]



**Fig.5- Auto generated layout of 4:1 MUX**

This layout occupied the area of 432.2 $\mu$ m<sup>2</sup> with power consumption by 25.645 $\mu$ w. The created layout can also be possible by semicustom design level.

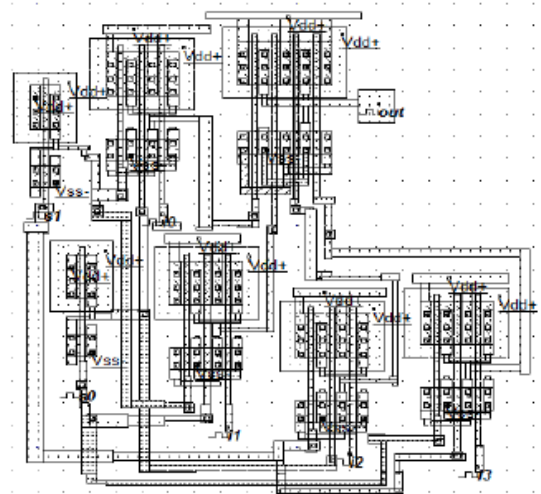

**Fig.6- Semicustom layout of 4:1 MUX**

The semicustom layout of 4:1 MUX is shown in the figure can be designed by different technologies 90nm. This layout occupies the area of 107.4 $\mu$ m<sup>2</sup> with power consumption of 23.937 $\mu$ w in 90nm technology . Simulations have been done with micro wind 3.1 tool and it is performed on the layout of Semicustom design level. The logic '0' and logic '1' corresponds to low and high level respectively. Clocks are applied as inputs and selection lines.

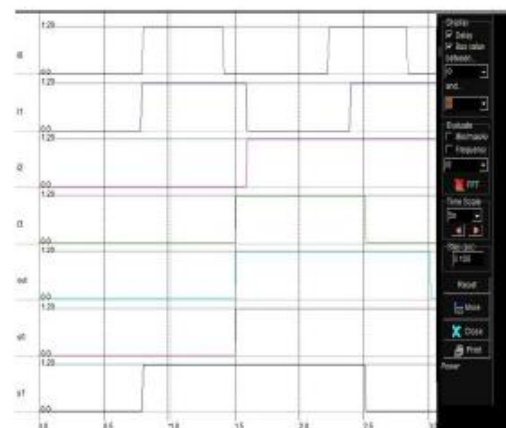

**Fig.7- Waveform of 4:1 MUX for semicustom design**

The 4:1 multiplexers have been designed by auto Generated and semicustom design tools. These are simulated and compared in terms of its power consumption and area at 90nm.

**Table2- Comparison in terms of power and area**

Technologies	Power	Area
Autogeneration (90nm)	25.645 $\mu$ w	432.2 $\mu$ m <sup>2</sup>
Semicustom (90nm)	23.937 $\mu$ w	107.4 $\mu$ m <sup>2</sup>

It has been observed that 4:1 multiplexer using Semicustom design level has low power consumption as compared to Auto generated design.

#### 4.PROPOSED MULTIPLEXER USING CMOS

There are two types of MOS, i.e. the NMOS and the PMOS. Where NMOS transistor can give the “LOW” signal completely, but it has poor performance at “HIGH” signal. Same as in PMOS transistor which gives the “LOW” signal completely but poor performance at “HIGH” signal [3][9]. CMOS transistor is the combination of NMOS and PMOS transistor which gives full output voltage swing. Power consumption is very less in CMOS circuits compared to the NMOS design and bipolar transistors. There are different design methodologies of designing of integrated circuit such as full custom design, semi custom design and standard cell based design.

In standard cell design, a design is captured using the standard cells available in a library via schematic or HDL [2]. In the full custom design the function and layout of practically every transistor is optimized [2]. This paper is based on the area efficient design 2 to 1 multiplexer using Micro wind tool. The schematic diagram of 2:1 MUX is as shown in fig.3.1. This circuit is designed with the help of universal NAND gates where 7 PMOS and 7 NMOS are used. The total numbers of 14 transistors are used in the CMOS design. P Switch is connected to the Vdd to the output and N switch is connected to the output to Vss [2]. In this CMOS design NMOS works as pull down network and PMOS works as pull up network.

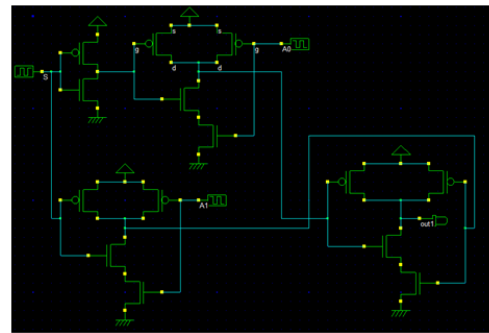

**Fig.3.1 Schematic of 2 To 1 Multiplexer Using NAND Gates**

Fig.3.2 shows the standard cell multiplexer layout design. Standard cell multiplexer design is complex and consumes more area.

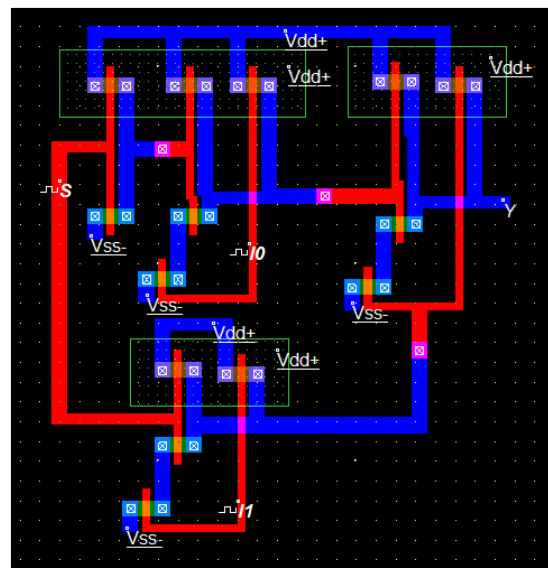

**Fig.3.3 Semi Custom Design Of 2 To 1 Multiplexer**

Fig.3.4 shows the design of 2 to 1 multiplexer using full custom layout design. Here all the PMOS's has designed with common n well. Common n well requires single supply to the circuit and reduces the power consumption in the 2 to 1 multiplexer circuit.

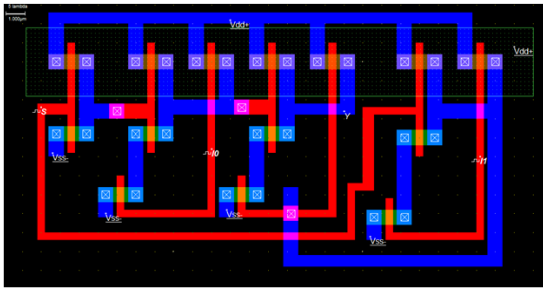

**Fig.3.4 Full Custom Design of 2 to 1 Multiplexer**

Fig.3.5 shows the simulation waveform of 2 to 1 multiplexer circuit. Here S is the selection line, I<sub>0</sub> and I<sub>1</sub> are inputs and Y is the output. When S is low, output will follow I<sub>0</sub> i.e. Y=I<sub>0</sub>. When S is High, output will follow the I<sub>1</sub> i.e. Y=I<sub>1</sub>. In this way the logic has been verified for standard based design, semi custom design and full custom design.

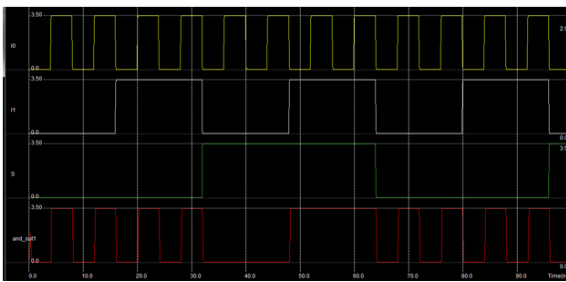

**Fig.3.5 Simulation Result Of 2 To 1 Multiplexer**

### 5.COMPARATIVE ANALYSIS

The main parameters of consideration are area, complexity and power of the 2 to 1 multiplexer in this paper. Table 4.1 shows the area and power consumption of 2 to 1 multiplexer circuit.

**Table 4.1 Area and Power consideration**

<b>Multiplexer Layout</b>	<b>Technology Used</b>	<b>AREA Used</b>	<b>POWER Consumption</b>
Standard Cell Based Design	35nm	696.3μm <sup>2</sup>	46.800μW
Semi Custom Design	35nm	593.9μm <sup>2</sup>	0.336mW
Full			

Custom Design	35nm	359.1μm <sup>2</sup>	0.142mW
---------------	------	----------------------	---------

Here 35nm technology is used in the designing of standard cell based layout, semi custom based layout and full custom layout of 2 to 1 multiplexer with the help of Microwind tool. Transistor width (w) = 0.200 micrometer and length L=0.100 micrometer has been used in the design.

### 6. CONCLUSION:

Multiplexer is the fundamental element in most commonly used circuits. This paper presented an efficient design of 4:1 MUX in Dsch and simulation using micro wind 3.1 tools. In auto generated and semi custom design levels. Among these two, the Semi custom is more power efficient, in which the designed circuit is realized in 90nm technology with reduced power consumption of 6.6% and area has been reduced to 75.1%. The result presented in this research work has future scope that circuit implementation using Full custom from which more area and power efficient design is expected.

### 7. REFERENCES

[1] Sung-Mo kang Yusuf Leblebici, “CMOS Digital Integrated circuit”, TATA Mc GRAW-HILL.

[2] Yashika Thakur, Rajesh Mehra, Anjali Sharma, “CMOS Design of Area & Power Efficient Multiplexer using Tree Topology”, International Journal of computer Application, vol. 112, no. 11, pp. 32-36, February 2015.

[3] Abhishek Dixit, Saurabh Khandelwal, Dr. Shyam Akashe, “Design Low Power High Performance 8:1 MUX using Transmission Gate Logic (TGL)”, International Journal of Modern Engineering & Management Research, vol. 2, issue. 2, pp. 14-20, June 2014.

[4] Richa Singh and Rajesh Mehra ‘Power Efficient Design of Multiplexer Using Adiabatic Logic’,

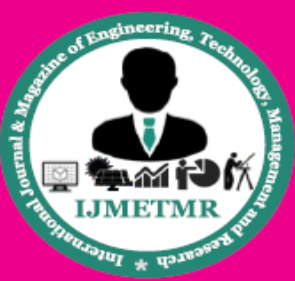

International Journal of Advances in Engineering and Technology, vol., no., pp.247-254, March 2013.

[5] Saurabh Rawat, Anushree Shah, Sumit Pundir, "Implementation of Boolean Function through Multiplexers with the help of Shannon Expansion Theorem", International Journal of Computer Application, vol. 62, no. 6, pp.18-24, January 2013.

[6] Ila Gupta, Neha Arora, Prof. BP. Singh, "New Design of High Performance 2:1 Multiplexer", International Journal of Engineering Research & Application, vol. 2, issue. 2, pp. 1492-1496, March-April 2012.

[7] Sarita, Jyoti Hooda, Shweta Chawla, "Design & Implementation of Low power 4:1 MUX using Adiabatic Logic", International Journal of Innovative Technology & Exploring Engineering (IJITEE), vol. 2, issue. 6, pp. 224-227, May 2013.

[8] M.Padmaja, V.N.V.Satya Prakash, "Design of a Multiplexer in Multiple Logic Styles for low Power VLSI", International Journal of Computers Trends and Technology, vol. 3, pp. 467-471, issue. 3, 2012.