

Energy Efficient Wireless Monitoring System for Agrarian Areas in Indian Agricultural System

Andrews Shara Jonitha

M.Tech Student,

Siddhartha Institute of Technology and Science.

S.Rajitha, M.Tech

Assistant Professor,

Siddhartha Institute of Technology and Science.

Introduction

Agriculture continues to play a major role in Indian Economy. Agriculture Sector is changing the socio-economic environments of the population due to liberalization and globalization. Irrigation system in India has given a high priority in economic development. Many new concepts are being developed to allow agricultural automation to flourish and deliver its full potential

Existing method:

The project irrigation control using AT89S52 is designed to tackle the problems of agricultural sector regarding irrigation system with available water resources. Prolonged periods of dry climatic conditions due to fluctuation in annual precipitation, may appreciably reduce the yield of the cultivation. The expenses in establishing many of these crops and their relative intolerance to drought make an effective irrigation system a necessity for profitable enterprises. In this project we are using AT89S52, Moisture sensors, AC submersible pump, relay driver. A submersible motor will get switched ON /OFF depending on the soil moisture condition and status of motor can be displayed on 16X2 LCD.

Draw back

Only one sensor is used and there is no remote monitoring

Proposed system

The atomization of agricultural environment for social modernization of Indian agricultural system using microcontroller and GSM, which is focused on automizing the irrigation system for social welfare of Indian agricultural system. The project is implemented by using advanced processor, GSM serves as an important on field and sends them to the receiver through coded signals. GSM operates through SMS and is the link between ARM processor and centralized unit.

In this project we are using humidity sensor and Traic boards in combination with MOC 3021 based Opto coupler which acts as a driver to operate the motor in case of dry condition detected by sensor. To check the status of day and night mode we are using LDR sensor. Temperature sensor is also included to monitor. The status can be displayed on 16X2 LCD. GSM modem is interfaced to send SMS for authorized person.

BLOCK DIAGRAM

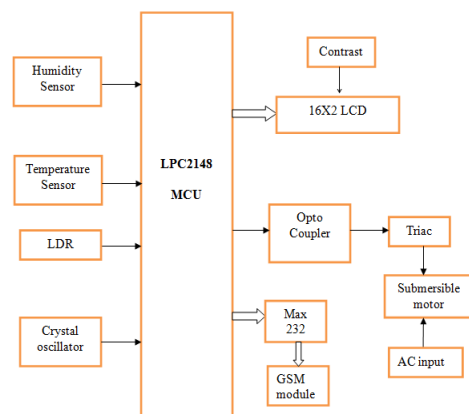
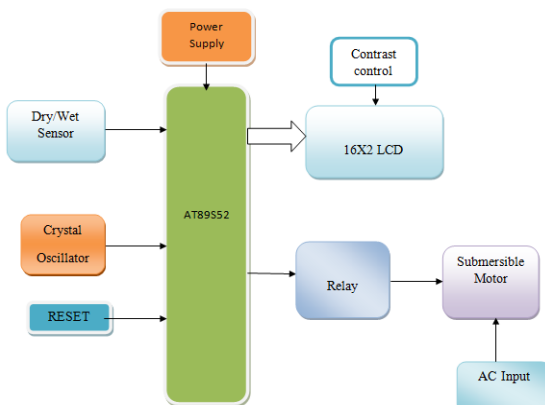

Hardware modules

LPC2148 controller

The **LPC2148** are based on a 16/32 bit ARM7TDMI-S™ CPU with real-time emulation and embedded trace support, together with 128/512 kilobytes of embedded high speed flash memory.

A 128-bit wide memory interface and unique accelerator architecture enable 32-bit code execution at maximum clock rate. For critical code size applications, the alternative 16-bit Thumb Mode reduces code by more than 30% with minimal performance penalty. With their compact 64 pin package, low power consumption, various 32-bit timers, 4- channel 10-bit ADC, USB PORT, PWM channels and 46 GPIO lines with up to 9 external interrupt pins these microcontrollers are particularly suitable for industrial control, medical systems, access control and point-of-sale. With a wide range of serial communications interfaces, they are also very well suited for communication gateways, protocol converters and embedded soft modems as well as many other general-purpose applications.

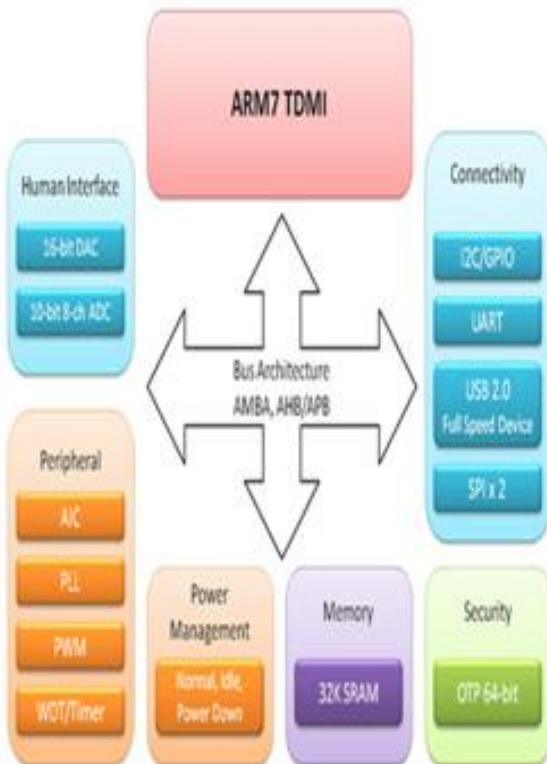

Architecture

ARM PROCESSOR:

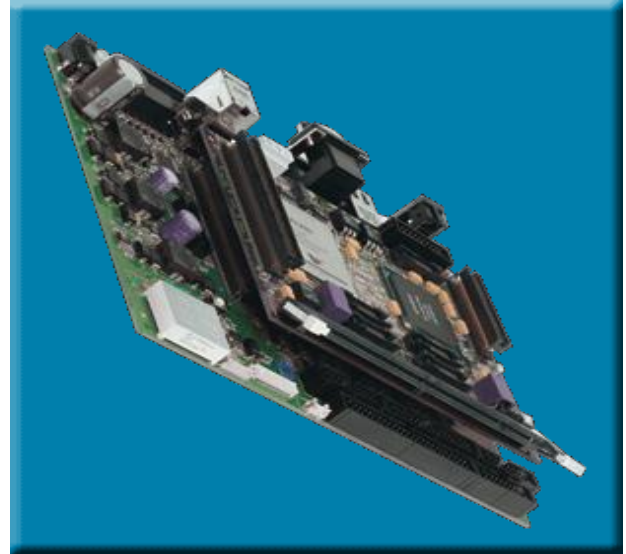

ARM7 board

LM35

FEATURES DESCRIPTION

- Calibrated Directly in ° Celsius (Centigrade)
- Linear + 10 mV/°C Scale Factor
- 0.5°C Ensured Accuracy (at +25°C)
- Rated for Full -55°C to +150°C Range
- Suitable for Remote Applications
- Low Cost Due to Wafer-Level Trimming
- Operates from 4 to 30 V
- Less than 60-μA Current Drain
- Low Self-Heating, 0.08°C in Still Air
- Nonlinearity Only ±1/4°C Typical
- Low Impedance Output, 0.1 Ω for 1 mA Load

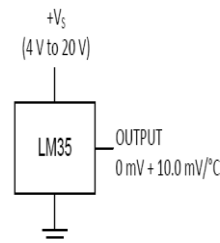
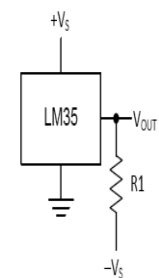

Figure 1. Basic Centigrade Temperature Sensor (+2°C to +150°C)



Choose $R_1 = -V_S / 50 \mu A$
 $V_{out} = 1500 \text{ mV at } 150^\circ C$
 $V_{out} = 250 \text{ mV at } 25^\circ C$
 $V_{out} = -550 \text{ mV at } -55^\circ C$

Figure 2. Full-Range Centigrade Temperature Sensor

Humidity(Dry and Wet) sensor



Soil moisture sensors measure the water content in soil. A soil moisture probe is made up of multiple soil moisture sensors. One common type of soil moisture sensors in commercial use is a Frequency domain sensor such as a capacitance sensor. Another sensor, the neutron moisture gauge, utilize the moderator properties of water for neutrons. Cheaper sensors -often for home use- are based on two electrodes measuring the resistance of the soil. Sometimes this simply consists of two bare (galvanized) wires, but there are also probes with wires embedded in gypsum.

soil moisture calibration

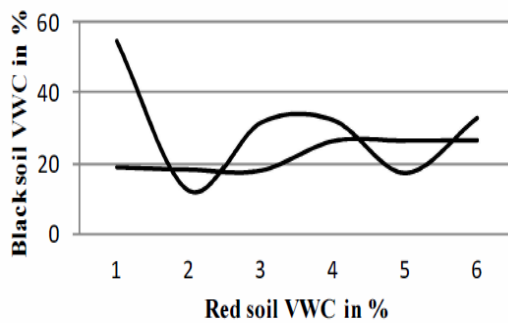

GSM



MODEM SPECIFICATIONS:

The SIM300 is a complete Tri-band GSM solution in a compact plug-in module.

Featuring an industry-standard interface, the SIM300 delivers GSM/GPRS900/1800/1900Mhz performance for voice, SMS, data and Fax in a small form factor and with low power consumption.

The leading features of SIM300 make it deal fir virtually unlimited application, such as WLL applications (Fixed Cellular Terminal), M2M application, handheld devices and much more.

- Tri-band GSM/GPRS module with a size of 40x33x2.85
- Customized MMI and keypad/LCD support
- An embedded powerful TCP/IP protocol stack
- Based upon mature and field proven platform, backed up by our support service, from definition to design and production.

SOFTWARE DETAILS

Software tools

Keil compiler is a software used where the machine language code is written and compiled. After compilation, the machine source code is converted into hex code which is to be dumped into the microcontroller for further processing. Keil compiler also supports C language code.

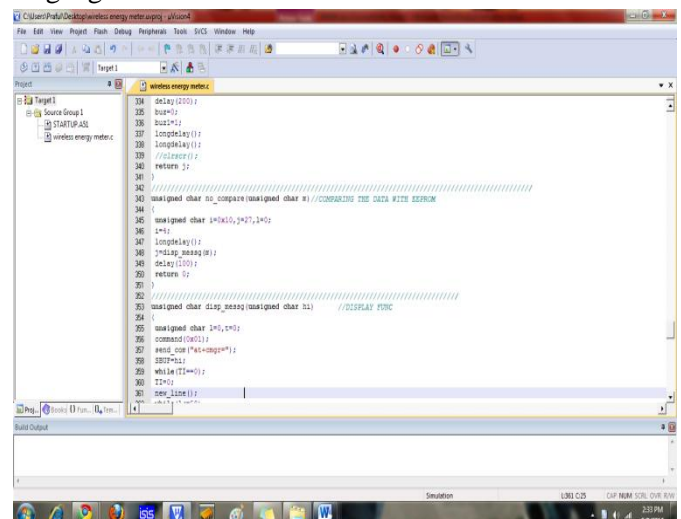

Flash Magic

Flash Magic is a tool which is used to program hex code in EEPROM of micro-controller. It is a freeware tool. It only supports the micro-controller of Philips and NXP. It can burn a hex code into that controller which supports ISP (in system programming) feature. Flash magic supports several chips like **ARM Cortex M0, M3, M4, ARM7 and 8051**.



ADVANTAGES

Device can be implemented with low cost, easy maintenance and human effort is reduced.

CONCLUSION

The experimental results of automated irrigation system are found to be sufficient energy efficient in the field of agriculture production for water resource optimization. Thus, the irrigation system allows optimized cultivation in places of water scarcity.

References

a. W.A. Jury and H. J. Vaux , "The emerging global water crisis: Managing scarcity and conflict between water users" , Adv. Agronomy , vol. 95 , pp.1 - 76 , 2007

b. X. Wang , W. Yang , A. Wheaton , N. Cooley and B. Moran , "Efficient registration of optical and IR images for automatic plant water stress assessment" , Comput. Electron. Agricult. , vol. 74 , no. 2 , pp.230 -237 , 2010

c. G. Yuan , Y. Luo , X. Sun and D. Tang , "Evaluation of crop water stress index for detecting water stress in winter wheat in the North China Plain" , Agricult. Water Manag. , vol. 64 , no. 1 , pp.29 -40 , 2004

d. S. B. Idso , R. D. Jackson , P. J. Pinter Jr. , R. J. Reginato and J. L. Hatfield , "Normalizing the stress-degree-day parameter for environmental variability" , Agricult. Meteorol. , vol. 24 , pp.45 -55 , 1981

e. Y. Erdem , L. Arin , T. Erdem , S. Polat , M. Deveci , H. Okursoy and H. T. Gülaltas , "Crop water stress index for assessing irrigation scheduling of drip irrigated broccoli (Brassica oleracea L. var. italica)" , Agricult. Water Manag. , vol. 98 , no. 1 , pp.148 -156 , 2010

f. K. S. Nemali and M. W. Van Iersel , "An automated system for controlling drought stress and irrigation in potted plants" , Sci. Horticult. , vol. 110 , no. 3 , pp.292 -297 , 2006

g. S. A. O'Shaughnessy and S. R. Evett , "Canopy temperature based system effectively schedules and controls center pivot irrigation of cotton" , Agricult. Water Manag. , vol. 97 , no. 9 , pp.1310 -1316 , 2010

h. R. G. Allen , L. S. Pereira , D. Raes and M. Smith , Crop Evapotranspiration-Guidelines for Computing Crop Water Requirements, FAO Irrigation and Drainage Paper 56 , 1998 :FAO

i. S. L. Davis and M. D. Dukes , "Irrigation scheduling performance by evapotranspiration-based controllers" , Agricult. Water Manag. , vol. 98 , no. 1 , pp.19 -28 , 2010

j. K. W. Migliaccio , B. Schaffer , J. H. Crane and F. S. Davies , "Plant response to evapotranspiration and soil water sensor irrigation scheduling methods for papaya production in south Florida" ,