

Rectifying Power Quality Problems Using a Static Compensator in Wind Energy System

**G. Boaz**

M.Tech (Electrical Power Systems),
Department of EEE,
Balaji Institute of Technology and Science,
Laknepally, Narsampet, Warangal, Telangana.

**S. Mallikarjun Reddy**

Associate Professor, Head Of Department,
Department of EEE,
Balaji Institute of Technology and Science,
Laknepally, Narsampet, Warangal, Telangana.

Abstract:

Recently, renewable wind energy is enjoying a rapid growth globally to become an important green electricity source to replace polluting and exhausting fossil fuel. Wind energy is considered to be a very promising alternative for power generation because of its alternative for power generation because of its tremendous environmental, social, and economic benefits. Electrical power generation from wind energy behaves quite differently from that of conventional sources. In this proposed scheme STATicCOMPensator (STATCOM) is connected at a point of common coupling with a battery energy storage system (BESS) to mitigate the power quality issues.

The battery energy storage is integrated to sustain the real power source under fluctuating wind power. The STATCOM control scheme for the grid connected wind energy generation system for power quality improvement is simulated using MATLAB/SIMULINK in power system block set. The effectiveness of the proposed scheme relieves the main supply source from the reactive power demand of the load and the induction generator. Finally a four leg converter is proposed for unbalanced loading conditions.

Keywords:

Statcom, Wind Energy, Static Compensator, Renewable energy, Harmonics, and Power Quality, 4 leg converter.

Introduction:

Power quality is one of the most important topics that electrical engineers have been noticed in recent years. The main problems related to power quality are Harmonic distortion and reactive power compensation. Most industries and companies prefer electrical energy with high quality. If delivered energy to these loads has poor quality, products and equipment of these loads such as microcontrollers, computers, motor drives etc are damaged. Hurt of this phenomenon in companies that dealing with information technology systems is serious. Nowadays, Custom Power equipments are used for this purpose. Until now, to filter these harmonics and to compensate reactive power at factory level, only capacitor and passive filters were used. More, new PWM based converters for motor control are able to provide almost unity power factor operations.

We cannot depend on this capacitor to filter out those harmonics. This is one of the reasons that the research is being done in the area of Active Power Filter (APF) and less pollutant drive. Loads, such as, diode bridge rectifier or a thyristor bridge feeding a highly inductive load, presenting themselves as current source at point of common coupling (PCC), can be effectively compensated by connecting an APF in shunt with the load. The term harmonics referred to Power quality in ideal world would mean how pure the voltage is, how pure the current waveform is in its sinusoidal form. Power quality is very important to commercial and industrial power system designs. Ideally, the electrical supply should be a perfect sinusoidal waveform without any kind of distortion.

If the current or voltage waveforms are distorted from its ideal form it will be termed as harmonic distortion. This harmonic distortion could result because of many reasons. In today's world, prime importance is given by the engineers to derive a method to reduce the harmonic distortion. Harmonic distortion was very less in the past when the designs of power systems were very simple and conservative. But, nowadays with the use of complex designs in the industry harmonic distortion has increased as well.

PRINCIPLE OF OPERATION:

STATCOM is to suppress voltage variation and control reactive power in phase with system voltage. It can compensate for inductive and capacitive currents linearly and continuously. Figure 3.6 show the vector diagram at the fundamental frequency for capacitive and inductive modes and for the transition states from capacitive to inductive and vice versa. The terminal voltage (V_{bus}) is equal to the sum of the inverter voltage (V_{VSC}) and the voltage across the coupling transformer reactance V_L in both capacitive and inductive modes. It means that if output voltage of STATCOM (V_{VSC}) is in phase with bus terminal voltage (V_{bus}) and V_{VSC} is greater than V_{bus} , STATCOM provides reactive power to system. And if V_{VSC} is smaller than V_{bus} , STATCOM absorbs reactive power from power system. V_{bus} and V_{VSC} have the same phase, but actually they have a little phase difference to compensate the loss of transformer winding and inverter switching, so absorbs some real power from system. A single-phase equivalent circuit of STATCOM is shown in Figure 3.5. Where, R_c is included to represent small losses in the switching devices of VSC. R_s and L represent the equivalent circuit of the tie-transformer between system voltages U_s and the output voltage U_I of STATCOM.

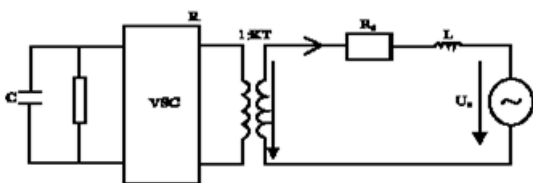

Single-phase equivalent circuit of STATCOM

VOLTAGE SOURCE CONVERTER (VSI):

A voltage-source converter is a power electronic device that connected in shunt or parallel to the system. It can generate a sinusoidal voltage with any required magnitude, frequency and phase angle.

The VSI used to either completely replace the voltage or to inject the "missing voltage". The "missing voltage" is the difference between the nominal voltage and the actual. It also converts the DC voltage across storage devices into a set of three phase AC output voltages. In addition, STATCOM is also capable to generate or absorbs reactive power. If the output voltage of the VSI is greater than AC bus terminal voltages, STATCOM is said to be in capacitive mode. So, it will compensate the reactive power through AC system and regulates missing voltages. These voltages are in phase and coupled with the AC system through the reactance of coupling transformers. Suitable adjustment of the phase and magnitude of the STATCOM output voltages allows effective control of active and reactive power exchanges between STATCOM and AC system. In addition, the converter is normally based on some kind of energy storage, which will supply the converter with a DC voltage.

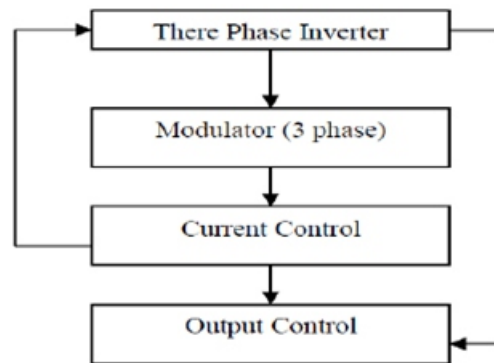

Modeling of Inverter

PROPOSED CONCEPT:

To pertain the distributed power system by maintaining sustainable improvement, it is necessary to tap the renewable energy sources. Energy conservation measures, the use of renewable sources are the main factors to meet the sustainable energy in these days. The integration of wind energy into existing power system presents a technical challenges and that requires consideration of voltage regulation, stability, power quality problems. The power quality is an essential customer-focused measure and is greatly affected by the operation of a distribution and transmission network. The power quality problem is of great importance to the wind turbine. There has been an extensive growth and quick development in the exploitation of wind energy now days.

Each unit has high capacity up to 2 MW, fed into distribution network, which is very near to the customers. Today, more than 28,000 wind generating turbines are successfully operating all over the world and India stands at position four in utilizing wind energy sources. International Electro-Technical Commission IEC-61400-21 describes the norms for power quality of micro-wind generating system. In the constant speed wind turbine operation, fluctuation of wind speed variation transmits as variation in mechanical torque. This leads to large variation of electrical power on the grid system. Under normal operating condition wind turbine has fluctuating output power. This fluctuation is caused by the variation of wind due to tower-shadow, turbulence and wind shear etc. Thus, the systems have ability to control such variations. The problems in power quality are viewed with the wind generation, transmission and distribution network due to voltage dip and flickers. The wind generator introduces disturbances in the distribution network. To reduce the disturbances, we use the induction generator connected directly to the grid system. The induction generator is simple and robust having reactive power for excitation. The active power varies due to fluctuating wind. The reactive power and terminal voltage of generator also varies with this. In normal operating system we need a control circuit for the active power production.

For reducing the disturbance we use a battery storage system. This compensates the disturbance generated by wind turbine. A STATCOM has been proposed for improving the power quality. This STATCOM technically manages the power level associated with the commercial wind turbines. This system produces a proper voltage level having power quality improvements. This system provides energy saving and uninterruptible power. The wind energy system is used to charge the battery as and when the wind power is available. The voltage source inverter is controlled by using the current control mode. The proposed system with battery storage has the following objectives:

- Unity power factor and power quality at point of common coupling.
- Real and reactive power support only from wind generator and batteries to load.
- Self-operation in case of grid failure.

The utility companies can view the current, voltage and power of each system simultaneously by using the online smart meters. The utility can measure power generation of each system simultaneously.

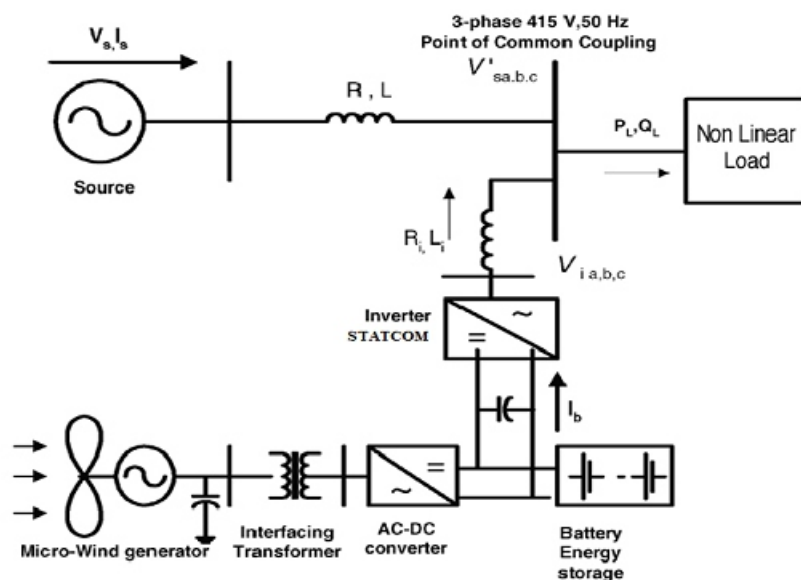

Scheme of wind generator with battery storage

Reference current for the STATCOM is generated based on instantaneous reactive power theory. A STATCOM injects the compensation current which is a sum of reactive component current of IG, non-linear load and harmonic component current of non-linear load.

P-Q theory gives a generalized definition of instantaneous reactive power, which is valid for sinusoidal or non-sinusoidal, balanced or unbalanced, three-phase power systems with or without zero sequence currents and/or voltages.

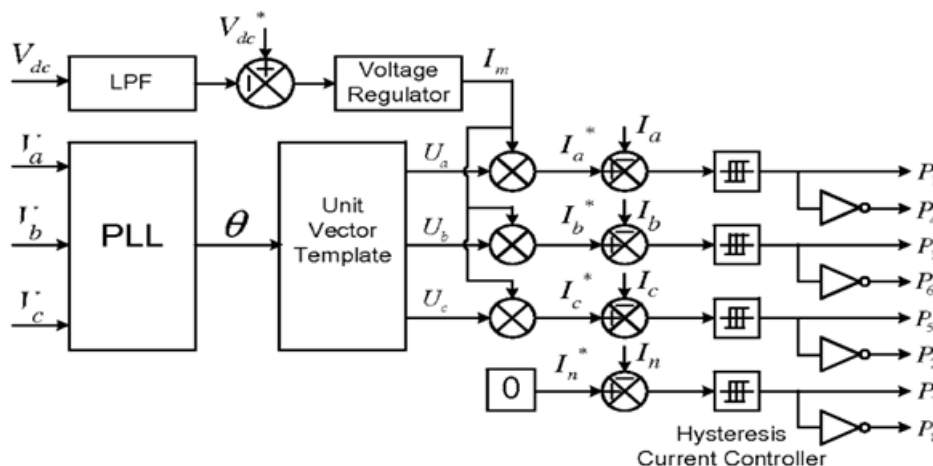

Block diagram representation of grid-interfacing inverter control.

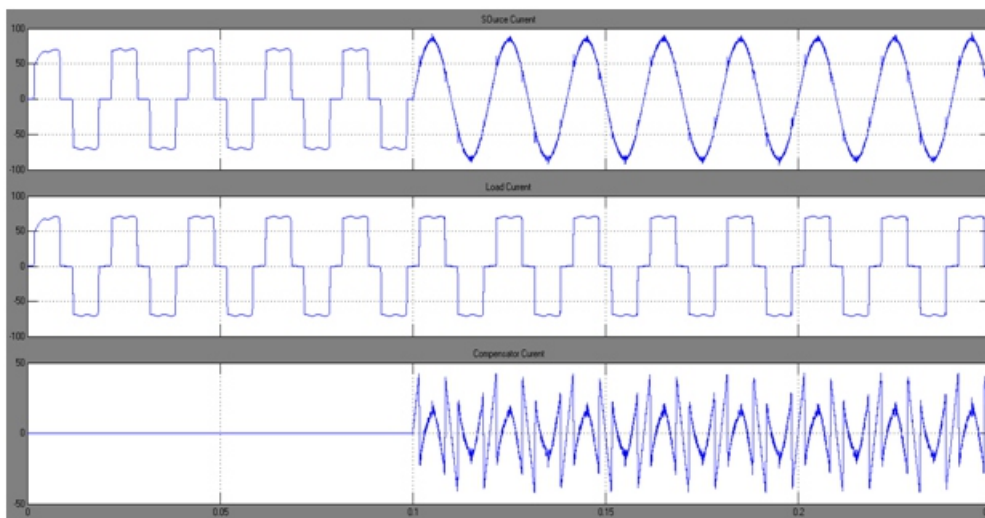

Figure 6.3: simulated wave forms of proposed system single phase source current, load current and compensator current

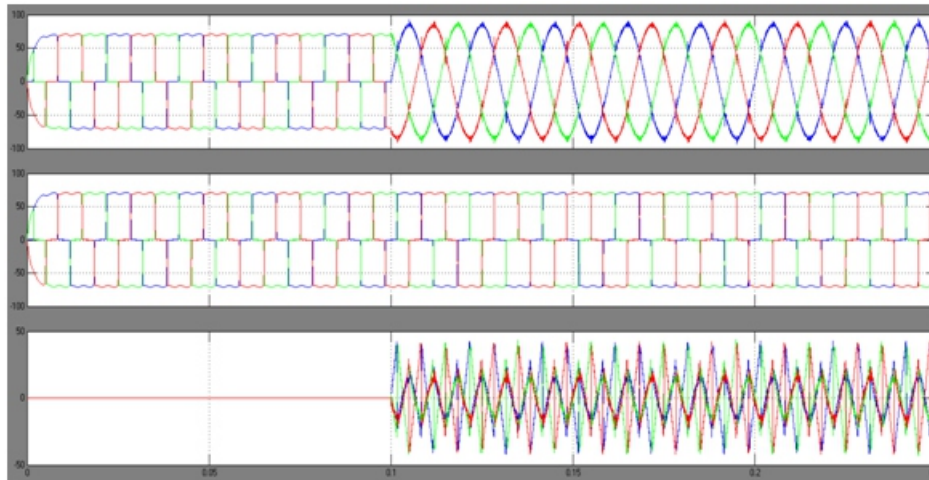

Figure 6.4: Simulated wave forms of proposed system three phase source current, load current and compensator current

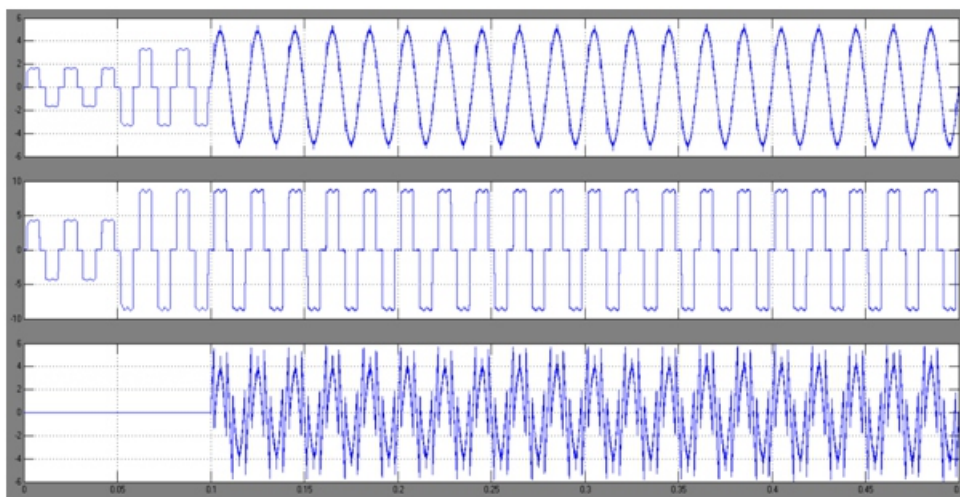

Figure 6.6: Simulated wave forms of 4-leg converter single phase source current, load current and compensator current

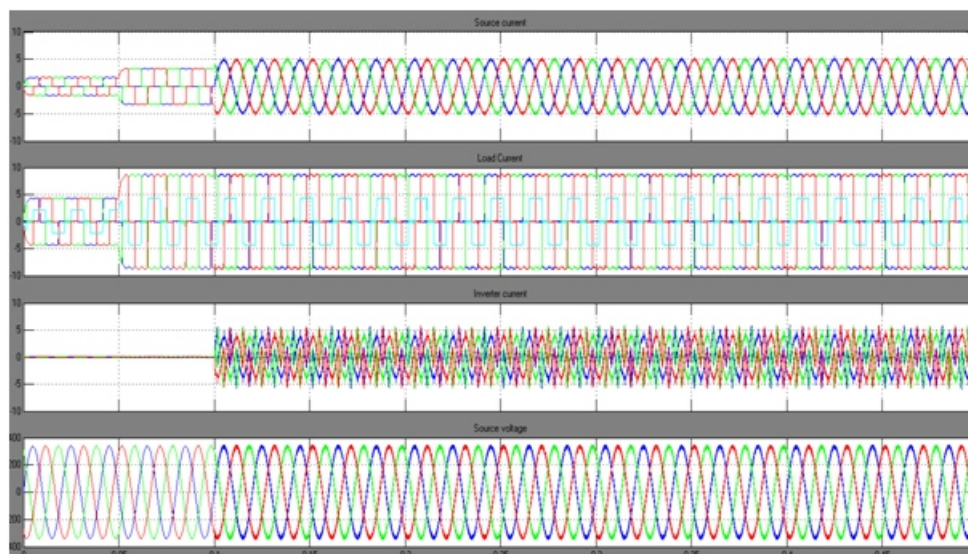

Figure 6.7: Simulated wave forms of 4-leg converter three phase source current, load current, compensator current and neutral current

CONCLUSION:

Proposed study on wind energy conversion scheme using battery energy storage for nonlinear load includes interface of inverter in current controlled mode for exchange of real and reactive power. The hysteresis current controller is used to generate the switching signal for inverter in such a way that it will cancel the harmonic current in the system. This scheme improves power factor and also makes harmonic free source current in the distributed network at the point of common connection. The wind power exchange is regulated across the dc bus having energy storage and is made available under the steady state condition. This also makes real power flow at instantaneous demand of the load. Rapid injection or absorption of reactive/real power flow in the power system can be made possible through battery energy storage and static compensator. Battery energy storage provides rapid response and enhances the performance under the fluctuation of wind turbine output and improves the voltage stability of the system. The utility can view each power plant simultaneously and accurately by using online smart meter. This scheme thus provides the system to operate both in power quality mode as well as in stand-alone.

REFERENCES:

- [1] C. Han, A. Q. Huang, M. Baran, S. Bhattacharya, and W. Litzemberger, "STATCOM impact study on the integration of a large wind farm into a weak loop power system" IEEE Transactions on Energy Conversion, vol. 23, no. 1, pp. 226232, March 2008.
- [2] J. Manel, "Power electronic system for grid integration of renewable energy source: A survey" IEEE Transactions on Industrial Electronics, vol. 53, no. 4, pp. 10021014, 2006, Carrasco.
- [3] R. Billinton and Y. Gao, "Energy conversion system models for adequacy assessment of generating systems incorporating wind energy", IEEE Transaction on Energy Conversion, volume. 23, no. 1, pp. 163169, December 2008.
- [4] S. W. Mohod and M. V. Aware, "Micro wind power generator with battery energy storage for critical load", in IEEE Systems Journal, Volume 6, no. 1, September 2012.
- [5] S. W. Mohod and M. V. Aware, "A STATCOM-Control scheme for Grid connected Wind Energy System for Power Quality Improvement", in IEEE Systems Journal, Volume 4, no. 3, September 2010.
- [6] K. S. Hook, Y. Liu, and S. Atcity, "Mitigation of the wind generation integration related power quality issues by energy storage", Energy power quality journal, volume XII, no. 2, September 2006.
- [7] S. W. Mohod and M. V. Aware, "Grid power quality with variable speed wind energy conversion", in IEEE International Conference Power Electronic Drives and Energy System (PEDES), Delhi, Dec. 2006.
- [8] Kulatunga N A, Navaratna S, Dole J, Liyanagendra C, Martin A T, "Hardware Development for Smart Meter Based Innovations", in Innovative Smart Grid Technologies in IEEE Conference, page 1 to 5, September 2012.
- [9] Jalilzadeh, Saeid; Kazemi, Ahad and Farhang, Peyman. "Analysis and Assessment of Power System Including Wind Farm by Using SVC and STATCOM", International Review of Electrical Engineering, 2012.
- [10] Saravana Murthy, P., P. Devaki, and J. Devishree. "A Static Compensation Method Based Scheme for Improvement of Power Quality in Wind Generation", 2011 International Conference on Process Automation Control and Computing, 2011.
- [11] Yuvaraj, V., S.N. Deepa, A.P. Roger Rozario, and Madhusudan Kumar. "Improving Grid Power Quality with FACTS Device on Integration of Wind Energy System", 2011 Fifth Asia Modelling Symposium, 2011.
- [12] Sharad W. Mohod. "Energy Storage to Stabilize the Weak Wind Generating Grid", 2008 Joint International Conference on Power System Technology and IEEE Power India Conference.