

Design and Implementation of Heart Rate Measurement Device Using Wireless System

Kamjula Shravan

M.Tech,

Vijaya Krishna Institute of Technology and Sciences,
Hyderabad, India.

Obula Reddy, M.Tech

Asst Prof,

Vijaya Krishna Institute of Technology and Sciences,
Hyderabad, India.

ABSTRACT:

Nowadays, the biomedical instrumentation holds a prominent position within medicine. Following this trend, the BPM (beat per minute) has become an important tool to elucidate about the functioning of the organism and wakeup for anomalies by monitoring the heartbeat in the human body. These devices are mostly used in hospitals and clinics but are gradually finding their way into domestic use. This paper demonstrates on an approach to design a cheap, accurate and reliable device which can easily measure the heart rate of a human body.

Introduction:

This project describes the design of a simple, low-cost controller based patient health monitoring system. Heart rate of the subject is measured from the thumb finger using IRD (Infra Red Device sensors). This instrument employs a simple Opto electronic sensor, conveniently strapped on the finger, to give continuous indication of the pulse digits. The Pulse monitor works both on battery or mains supply. It is ideal for continuous monitoring in operation theatres, I.C.units, biomedical/human engineering studies and sports medicine.

By reading pulse values continuously from pulse count sensor placed to the fore finger of patient. These values are encoded and sent to remote station using RF communication. Alpha numeric LCD is provided on receiver end to display the heart rate measurement. This project uses regulated 5V, 750mA power supply. 7805 three terminal voltage regulator is used for voltage regulation. Bridge type full wave rectifier is used to rectify the ac out put of secondary of 230/12V step down transformer.

Transmitter:

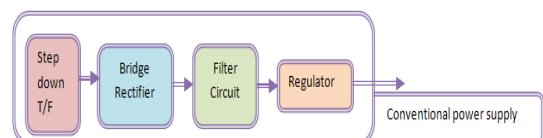
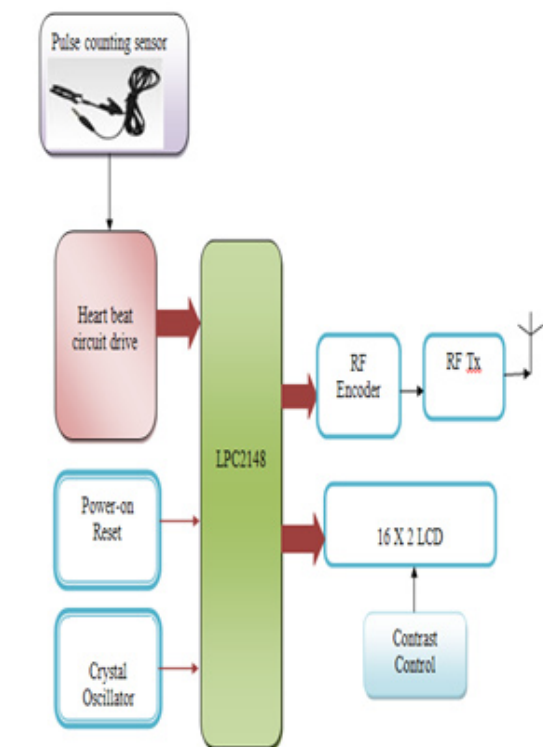

Receiver:

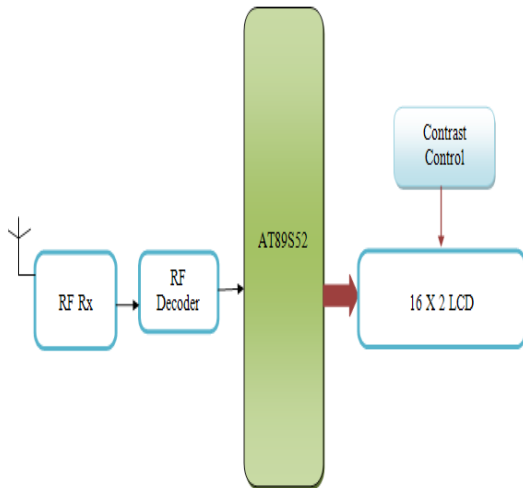

Hardware requirements:

LPC2148 controller:

The LPC2148 are based on a 16/32 bit ARM7TDMI-S™ CPU with real-time emulation and embedded trace support, together with 128/512 kilobytes of embedded high speed flash memory. A 128-bit wide memory interface and unique accelerator architecture enable 32-bit code execution at maximum clock rate. For critical code size applications, the alternative 16-bit Thumb Mode reduces code by more than 30% with minimal performance penalty. With their compact 64

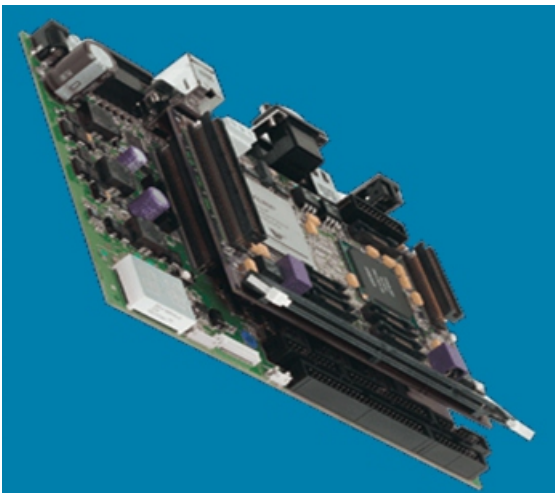

RF communication:

Radio frequency (RF) is a frequency or rate of oscillation within the range of about 3 Hz to 300 GHz. This range corresponds to

pin package, low power consumption, various 32-bit timers, 4- channel 10-bit ADC, USB PORT, PWM channels and 46 GPIO lines with up to 9 external interrupt pins these microcontrollers are particularly suitable for industrial control, medical systems, access control and point-of-sale. With a wide range of serial communications interfaces, they are also very well suited for communication gateways, protocol converters and embedded soft modems as well as many other general-purpose applications. frequency of alternating current electrical signals used to produce and detect radio waves. Since most of this range is beyond the vibration rate that most mechanical systems can respond to, RF

TRANSMITTER STT-433MHz:

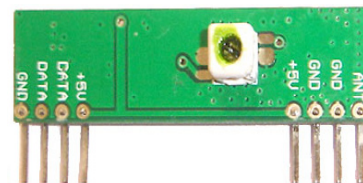

RF usually refers to oscillations in electrical circuits or electromagnetic radiation

- Frequency : 2.4~2.524 GHz
- Modulation type: GFSK
- Op. Voltage: 3V
- Output Power: +4dBm
- Data Rate: 1Mbps
- Small footprint size: 20.0 x 36.7 x 2.4mm
- Operating Temperature: -40 ~ + 85 C
- Long range : estimated 100mts @250Kbps ; 50mts @1Mbps , Line of Sight
- Built-in antenna.
- Real full-duplex, including decoder, encoder and data buffer. Very low cost

RF RECEIVER STR-433 MHz

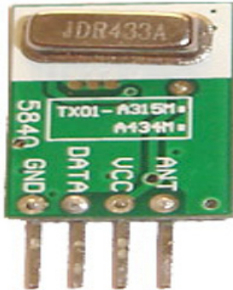

LCD:

LCD stands for Liquid Crystal Display. LCD is finding wide spread use replacing LEDs (seven segment LEDs or other multi segment LEDs) because of the following reasons:

- 1.The declining prices of LCDs.
- 2.The ability to display numbers, characters and graphics. This is in contrast to LEDs, which are limited to numbers and a few characters.
- 3.Incorporation of a refreshing controller into the LCD, thereby relieving the CPU of the task of refreshing the LCD. In contrast, the LED must be refreshed by the CPU to keep displaying the data.
- 4.Ease of programming for characters and graphics.

These components are “specialized” for being used with the microcontrollers, which means that they cannot be activated by standard IC circuits. They are used for writing different messages on a miniature LCD.

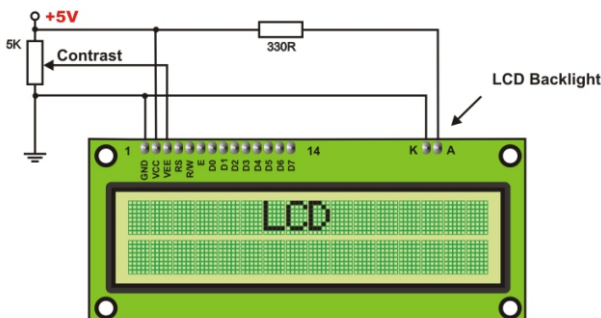

HEART BEAT CIRCUIT DRIVE



Heart rate is the speed of people’s emotional state, exercise intensity and objective indicator of cardiac function. But most people are very difficult to accurately measure the time and his heart rate values. If the heart rate monitor with me, heart ECG electrodes will be detected by monitoring the signal processing device, the user can at any time that your heart rate changes, changes in heart rate, self-monitoring status.

Schematic representation

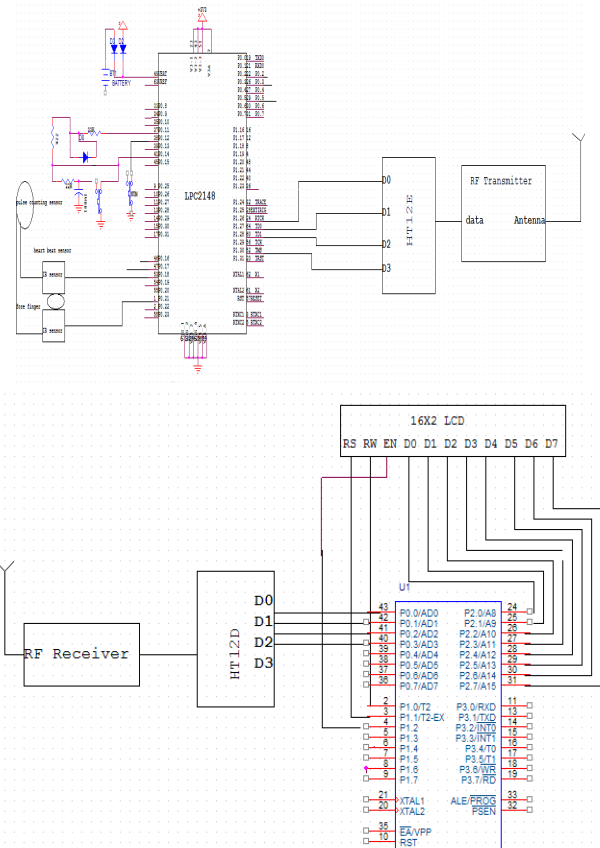

Expensive equipment used in hospitals

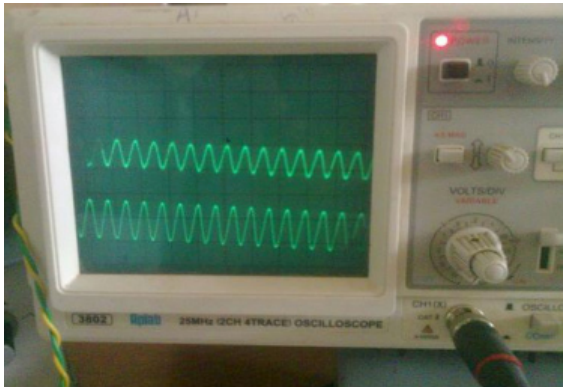

Result of our project displaying normal heart rate

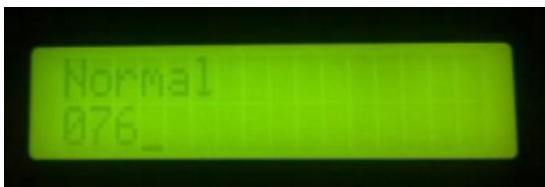

Advantages:

- Ease of operation
- Low maintenance cost
- Fit and forget system
- No wastage of time
- Durability
- Accuracy

Applications:

- Hospitals
- Remote heart rate monitoring applications
- Local monitoring applications
- Designed for Home and Clinical Applications

Future scope:

The project can be further developed in future by adding expert system features like speed variations with moving screen, exact heart rate with analysis, displaying 12 lead graphs, and monitoring ECG wave form on PC monitor. We can enhance the feature of the project by enabling the transmission of ECG signals through mobiles, signal transmitters or internet.

Conclusion:

This project was successfully implemented and the output displayed was on LCD and Heart rate is counted by microcontroller for one minute and displayed at distant place through RF communication.

References:

- [1] A. R. Houghton and D. Gray., "Making sense of the ECG", Hodder Arnold Publishing's 2003.
- [2] Forerunner 201/301 User Guide, web site: <http://www.grmin.com>.
- [3] Pulsar heart rate monitors, web site: <http://www.heartratemonitor.co.uk>.
- [4] David A. Bell, "Operational amplifiers and linear ICs", 2nd Edition, Oxford University Press, 1997.
- [5] Kenneth.J.Ayala,"The 8051 Microcontroller Architecture programming and Applications", 2nd Edition.
- [6] Janicegillispie Mazidi, Muhammad Ali Mazidi,"The 8051Microcontroller and Embedded System", 2nd Edition, Person Education 2009.
- [7] Webster John G., "Medical Instrumentation. Application and Design", 3rd Edition Wiley, 1998.
- [8] Ramakant A. Gayakwad, "Op-amps and linear integrated circuits", 2ndEdition Prentice Hall, 2000..
- [9] ECG Measurement System -Chia-Hung Chen, Shi-Gun Pan, Peter Kinget.
- [10] Daniel Paulus / Thomas Meier,"ECG-Amplifier", MB Jass 2009.
- [11] G.M.Patil, K.Subbarao, V.D.Mytri, A.D. Rajkumar, D.N.Reddy and K. "Embedded Microcontroller based Digital Telemonitoring System for ECG", J. Instrum. Soc. India 37(2) 134-149.
- [12] Dr. P. K. Dash, "Electrocardiogram Monitoring", Indian J. Anaesth. 2002; 46 (4): 251-256.
- [13] A. Karilainen, T. Finnberg et. Al... Mobile Patient Monitoring Based on Impedance-Loaded SAW-Sensors. IEEE Transactions on Ultrasonics, Ferroelectrics and Frequency Control. Vol. 51. No. 11. Pp 1464 – 1469.2004.