

## **Structural Design and FEM Analysis of Large Butterfly Valve**

**Garaga V Chaitanya Bharath Kumar**

**M.Tech (CAD/CAM),**

**Jawaharlal Nehru Technological University  
Kakinada, Kakinada, AP, India.**

**M.Madusudan Prasad**

**Assistant Professor,**

**Department of Mechanical Engineering,  
University College of Engineering, Kakinada.  
Jawaharlal Nehru Technological University  
Kakinada, Kakinada, AP, India.**

### **ABSTRACT:**

Valves for hydro power projects are installed for safety, maintenance, and shut-off, as well as for flow and pressure regulation. A Butterfly valve is a type of flow control device, which is widely used to regulate a fluid flowing through a section of pipe. This type of valve is mainly used as safety valve, turbine inlet valve, and pump valve for low to medium design pressures. They are operated by oil hydraulic systems for opening and closing or by closing weight and hydraulic pressure for opening. For turbine inlet valves, oil pressure can also be taken from the governor hydraulic oil system. The sealing system is of flexible, adjustable rubber/metal type to reduce leakage to a minimum. Water flow through the valve is possible in both directions. The main objective of this thesis work is to analyse the option of fabricated variant for door & body in place of casted, reduction in the material of valve body & door by structural design & FEM analysis & optimization in the material of valve component. The 3D modeling to be performed for butterfly valve by using CAD software. Further the stress & displacement FEM analysis of the butterfly valve to be performed by using ANSYS tool to evaluate the optimized result.

### **INTRODUCTION BUTTERFLY VALVE**

A butterfly valve is a valve which can be used for isolating or regulating flow. The closing mechanism takes the form of a disk. Operation is similar to that of a ball valve, which allows for quick shut off. Butterfly valves are generally favored because they are lower in

cost to other valve designs as well as being lighter in weight, meaning less support is required. The disc is positioned in the center of the pipe, passing through the disc is a rod connected to an actuator on the outside of the valve. Rotating the actuator turns the disc either parallel or perpendicular to the flow. Unlike a ball valve, the disc is always present within the flow, therefore a pressure drop is always induced in the flow, regardless of valve position. A butterfly valve is from a family of valves called quarter-turn valves. In operation, the valve is fully open or closed when the disc is rotated a quarter turn. The "butterfly" is a metal disc mounted on a rod. When the valve is closed, the disc is turned so that it completely blocks off the passageway. When the valve is fully open, the disc is rotated a quarter turn so that it allows an almost unrestricted passage of the fluid.

The valve may also be opened incrementally to throttle flow. There are different kinds of butterfly valves, each adapted for different pressures and different usage. The zero offset butterfly valve, which uses the flexibility of rubber, has the lowest pressure rating. The high performance double offset butterfly valve, used in slightly higher-pressure systems, is offset from the centre line of the disc seat and body seal (offset one), and the centre line of the bore (offset two). This creates a cam action during operation to lift the seat out of the seal resulting in less friction than is created in the zero offset design and decreases its tendency to wear. The valve best suited for high-pressure systems is the triple offset butterfly valve. In this valve the disc seat contact axis is offset, which acts to virtually eliminate sliding contact between disc and seat.

In the case of triple offset valves the seat is made of metal so that it can be machined such as to achieve a bubble tight shut-off when in contact with the disc.

### Introduction to Valves - Butterfly valves

#### Butterfly valves

A Butterfly valve is a quarter-turn rotational motion valve, that is used to stop, regulate, and start flow. Butterfly valves are easy and fast to open. A 90° rotation of the handle provides a complete closure or opening of the valve. Large Butterfly valves are usually equipped with a so-called gearbox, where the handwheel by gears is connected to the stem. This simplifies the operation of the valve, but at the expense of speed.



#### Types of Butterfly valves:

Butterfly valves has a short circular body, a round disc, metal-to-metal or soft seats, top and bottom shaft bearings, and a stuffing box. The construction of a Butterfly valve body varies. A commonly used design is the wafer type that fits between two flanges. Another type, the lug wafer design, is held in place between two flanges by bolts that join the two flanges and pass through holes in the valve's outer casing. Butterfly valves are even available with flanged, threaded and butt welding ends, but they are not often applied. Butterfly valves possess many advantages over gate, globe, plug, and ball valves, especially for large valve applications. Savings in weight, space, and cost are the most obvious advantages. The maintenance costs are usually low because there are a minimal number of moving parts and there are no pockets to trap fluids.

Butterfly valves are especially well-suited for the handling of large flows of liquids or gases at relatively low pressures and for the handling of slurries or liquids with large amounts of suspended solids. Butterfly valves are built on the principle of a pipe damper. The flow control element is a disk of approximately the same diameter as the inside diameter of the adjoining pipe, which rotates on either a vertical or horizontal axis. When the disk lies parallel to the piping run, the valve is fully opened. When the disk approaches the perpendicular position, the valve is shut. Intermediate positions, for throttling purposes, can be secured in place by handle-locking devices.

#### Triple eccentric butterfly valve for oil & gas industry

##### Butterfly valve Seat Construction

Stoppage of flow is accomplished by the valve disk sealing against a seat that is on the inside diameter periphery of the valve body. Many Butterfly valves have an elastomeric seat against which the disk seals. Other Butterfly valves have a seal ring arrangement that uses a clamp-ring and backing-ring on a serrated edged rubber ring. This design prevents extrusion of the O-rings. In early designs, a metal disk was used to seal against a metal seat. This arrangement did not provide a leak-tight closure, but did provide sufficient closure in some applications (i.e., water distribution lines).

##### Butterfly valve Body Construction

Butterfly valve body construction varies. The most economical is the wafer type that fits between two pipeline flanges. Another type, the lug wafer design, is held in place between two pipe flanges by bolts that join the two flanges and pass through holes in the valve's outer casing. Butterfly valves are available with conventional flanged ends for bolting to pipe flanges, and in a threaded end construction.

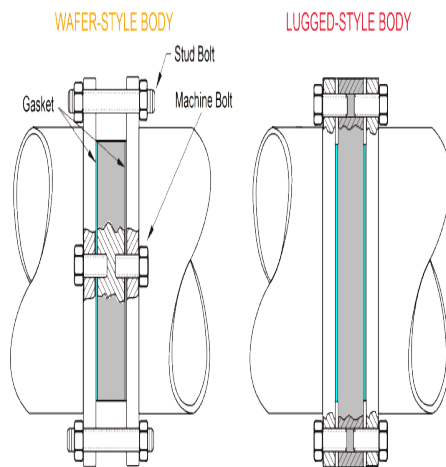

### Seat Disk and Stem of a Butterfly valve:

The stem and disk for a Butterfly valve are separate pieces. The disk is bored to receive the stem. Two methods are used to secure the disk to the stem so that the disk rotates as the stem is turned. In the first method, the disk is bored through and secured to the stem with bolts or pins. The alternate method involves boring the disk as before, then shaping the upper stem bore to fit a squared or hex-shaped stem. This method allows the disk to "float" and seek its center in the seat. Uniform sealing is accomplished and external stem fasteners are eliminated. This method of assembly is advantageous in the case of covered disks and in corrosive applications.

In order for the disk to be held in the proper position, the stem must extend beyond the bottom of the disk and fit into a bushing in the bottom of the valve body. One or two similar bushings are along the upper portion of the stem as well. These bushings must be either resistant to the media being handled or sealed so that the corrosive media cannot come into contact with them. Stem seals are accomplished either with packing in a conventional stuffing box or by means of O-ring seals. Some valve manufacturers, particularly those specializing in the handling of corrosive materials, place a stem seal on the inside of the valve so that no material being handled by the valve can come into contact with the valve stem. If a stuffing box or external O-ring is employed, the fluid passing through the valve will come into contact with the valve stem.

### Material used for butterfly valves

#### Existing material

#### Carbon Steel

Carbon steel is an alloy of iron where the main alloying element is carbon. Generally, no other alloying elements are added to control the properties of the material. For butterfly valve construction, carbon steel is most often used to form the body and disc of the valve using the sand casting process. Carbon steels are available in several different grades. The most common grades used for valve bodies and discs are cast grades ASTM A216 WCB (Weldable Cast B-grade) and LCC (Low Carbon Content) steels. WCB material is most suitable for high temperature use, whereas LCC can be used at low (sub-zero) temperatures.

#### Main Advantage of carbon steel:

The cost – carbon steels are relatively cheap, and valves produced from carbon steels provide a cost-effective solution in environments where other factors are considered less important than cost.

#### Main disadvantage of carbon steel:

Poor corrosion resistance. This can be overcome by surface protection such as paint, provided that the line media does not corrode the valve from the inside.

#### Stainless Steel:

The definition of a stainless steel is an alloy of iron with a minimum chromium content of 10.5%. The effect of the chromium is to form a self-healing layer of chromium oxide on the surface of the material. When the surface is broken by mechanical damage such as scratching, the chromium quickly reacts with oxygen in the air, so preventing the oxygen from reacting with the iron and forming iron oxide (rust). An ever-increasing number of stainless steels are available, of which the simple iron-chromium-nickel grades are most often termed 'stainless steel'. Stainless steels can be further classified as ferritic, austenitic, martensitic, duplex and precipitation hardenable. This classification is based on the microstructure that is developed in the material by varying the alloying

elements present. For valve construction, the most common grades used are austenitic and duplex. These are described briefly below.

**Austenitic stainless steels:**

Austenitic stainless steels, in addition to chromium, contain elements such as nickel, which have the effect of retaining the high temperature face-centred-cubic austenitic structure at temperatures where it would normally have transformed to the ferritic body-centred-cubic structure. This face-centred cubic structure gives the material improved toughness and ductility compared to the ferritic grades. Depending on the nickel content, the tough austenitic structure can be retained even at extremely low temperatures, allowing the material to be used in cryogenic applications. Improved resistance to pitting corrosion can be achieved by adding molybdenum to the alloy.

**Duplex stainless steels:**

Duplex stainless steels contain a balanced structure of both the austenitic face-centred cubic and ferritic body-centred structure of iron. This structure is developed by carefully controlling both the alloying elements and the heat treatment performed on the alloy to obtain a structure consisting of 50% austenite and 50% ferrite. The result is an alloy that combines the higher strength of ferrite with the improved toughness of austenite. The super duplex grades contain higher levels of chromium and molybdenum to enhance their resistance to pitting and crevice corrosion.

**Body**

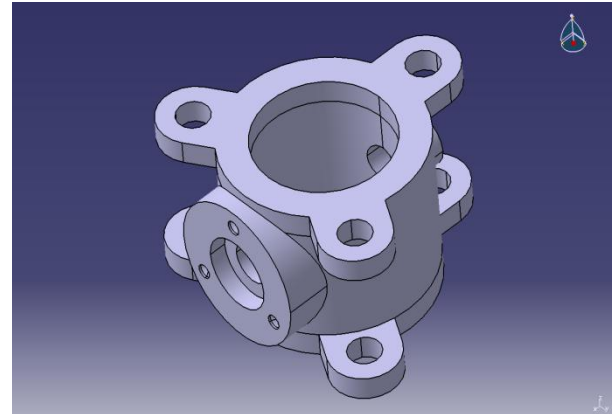

**Shaft**

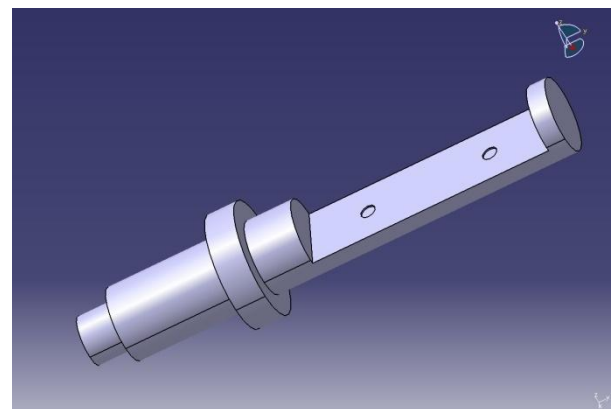

**Connecting element**

**STRUCTURAL ANALYSIS OF TITANIUM BRONZE**

**Displacement**

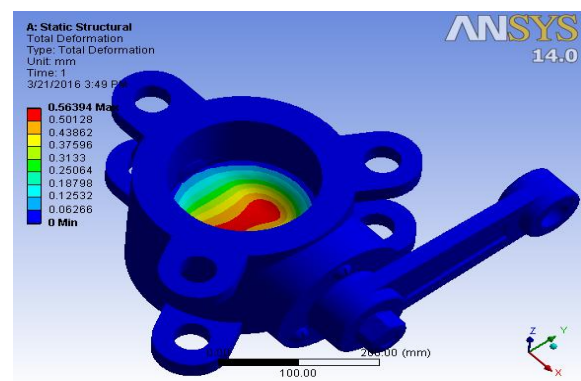

**Design model**

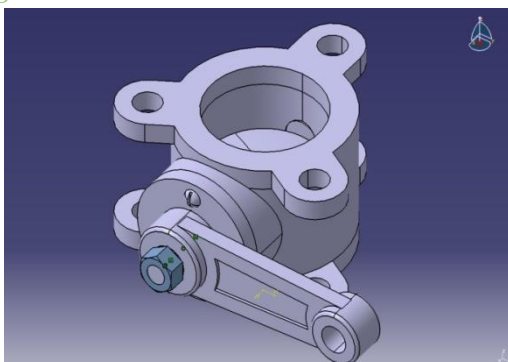

**Strain**

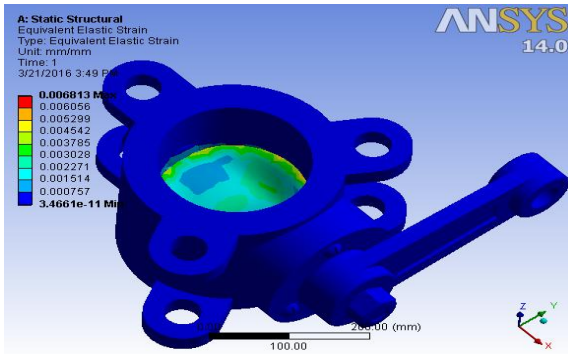

**Stress**

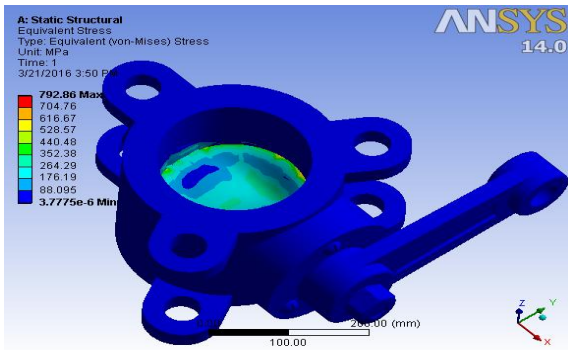

**Results and conclusion**

**Results:**

Weight of butterfly valve with existing design

- Titanium bronze : 92.1924 kg
- Nickel aluminum bronze : 93.574 kg
- Carbon steel : 93.604 kg

Weight of butterfly valve with new design

- Titanium bronze : 93.82 kg
- Nickel aluminum bronze : 94.67 kg
- Carbon steel : 94.73 kg

**Results table**

Material	Displacement (mm)		Stress (MPa)		Strain (mm/mm)	
	Min	Max	Min	Max	Min	Max
Carbon steel	0	0.4207	5.707e-6	831.09	4.527e-11	0.004207
Titanium bronze	0	0.5639	3.77e-6	792.86	3.466e-11	0.00681
Nickel aluminum bronze	0	0.54048	3.789e-6	769.99	3.497e-11	0.00634

**Conclusion:**

From the results it is concluded that the results obtained with new design is best than previous or existing design. As shown in results the stress value found out with help of carbon steel is 831.09 MPa where as stress value obtained with the nickel aluminum bronze is 769.99 MPa. And stress value obtained with titanium bronze is 792.86 MPa. And also displacement value obtained with carbon steel is more than nickel aluminum bronze and titanium bronze. So from results it is concluded that the best material used for butterfly valve amongst three is nickel aluminum bronze.

**References:**

- 1) X G Song, L Wang and Y C Park, 'Analysis and optimization of a butterfly valve disc', Proceedings of the Institution of Mechanical Engineers, Part E: Journal of Process Mechanical Engineering, 223: 81, 2009.
- 2) Xue Guan Song, Lin Wang, Young Chul Park, 'Fluid and structural analysis of a large diameter

butterfly valve', Journal of Advanced Manufacturing Systems, Vol. 8, No. 1, 81–88, 2009.

3) Xue Guan Song, Lin Wang, Seok Heum Baek, Young Chul Park, 'Multidisciplinary optimization of a butterfly valve', ISA Transactions, 48, 370-377, 2009.

4) Philip L. Skousen, 'Valve Handbook', Second Edition, McGraw-Hill.

[5] Morris M. J. and Dutton J. C., 1989, "Compressible Flowfield Characteristics of Butterfly Valves", ASME J. Fluids Eng., 111, pp.400-407

[6] Kimura, T., Tanaka, T., Fujimoto, K., and Ogawa, K., 1995, "Hydrodynamic Characteristics of a Butterfly Valve - Prediction of Pressure Loss Characteristics," ISA Trans., 34(4), pp. 319{326.

[7] Huang, C., and Kim, R.H., 1996, "Three-dimensional Analysis of Partially Open Butterfly Valve Flows," J. Fluids Engineering, 118(3), pp. 562{568.

[8] Lin, F., and Schohl, G.A., 2004, "CFD Prediction and Validation of Butterfly Valve Hydrodynamic Forces," Proceedings of the World Water and Environmental Resources Congress, pp. 1{8.

[9] Hoerner, S., 1958, Fluid-Dynamic Drag: Practical Information on Aerodynamic Drag and Hydrodynamic Resistance, Hoerner Fluid Dynamics, CA.

[10] Song, X., Wang, L., and Park, Y., 2008, "Fluid and Structural Analysis of Large Butterfly Valve," AIP Conference Proceedings, 1052, pp. 311{314.

[11] Song, X., and Park, Y.C., 2007, "Numerical Analysis of Butterfly Valve - Prediction of Flow Coefficient and Hydrodynamic Torque Coefficient," In Proceedings of the World Congress on Engineering and Computer Science, pp. 759{763.

[12] Xue Guan Song, Young Chul Park, "Numerical Analysis of butterfly valve prediction of flow coefficient and hydrodynamic torque coefficient", world congress on engineering and computer science, October 2007, San Francisco, USA.