

Building Automation Control System Using ARM7 and IOT

Amaranadh Bolla

M-Tech, Embedded Systems,
Dept of ECE,

St.Mary's Group of Institutions, Guntur, A.P.

S.Naveen Kumar, Masters

Assistant Professor,
Dept of ECE,

St.Mary's Group of Institutions, Guntur, A.P.

ABSTRACT:

A firmware developed for Smart Switch, which can control the on-off of any electrical device at home by using internet. The manual switching of any home appliance is an inconvenient method for physically disabled or elders or even for normal young guys when frequent switching operation is required. Thus, this conventional manual switching method has to be overcome by an easier method of switching. This can be done using an advanced switching method like a remote control for electrical home appliances.

Introduction

Home control system (HCS) is a general term that encompasses several types of control systems used in industrial production, including supervisory control and data acquisition (SCADA) systems, distributed control systems (DCS), and other smaller control system configurations such as programmable logic controllers (PLC) often found in the industrial sectors and critical infrastructures. ICSs are typically used in industries such as electrical, water, oil, gas and data. Based on data received from remote stations, automated or operator-driven supervisory commands can be pushed to remote station control devices, which are often referred to as field devices. Field devices control local operations such as opening and closing valves and breakers, collecting data from sensor systems, and monitoring the local environment for alarm conditions.

Literature survey

Existing system

Automatic Light Control System is a simple yet powerful concept, which uses transistor as a switch. By using this system manual works are 100% removed.

It automatically switches ON lights when the sunlight goes below the visible region of our eyes. This is done by a sensor called Light dependent Resistor (LDR) which senses the light actually like our eyes. It automatically switches OFF lights whenever the sunlight comes, visible to our eyes.

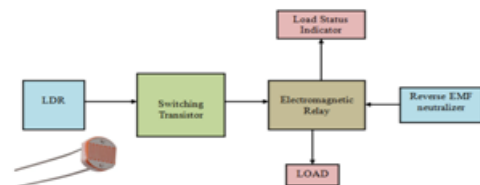

Draw Back:

Light will be on at night time even when there is no work there.

Proposed System:

In Industry/home we have different types of loads at different locations. We can control all loads at a time from one place (control room) without connecting any physical wire between loads and control room. In this project we are using WI-FI module, LPC2148, TRIAC. Smart phone acts as a remote to operate the loads. Here we are using a technology known as Internet of things (IoT), in which we can wirelessly operate any industrial/home appliances by communicating IoT module with the controlling system. The main system of the project is ARM7 LPC2148 microcontroller to which all input outputs are interfaced. The input to system is IoT ESP8266 and outputs are LCD and four loads. The ARM7 LPC2148 takes input from the IoT and gives output to the loads which are interfaced through TRIAC and driver circuit. The status of the system is being displayed on LCD.

BLOCK DIAGRAM:

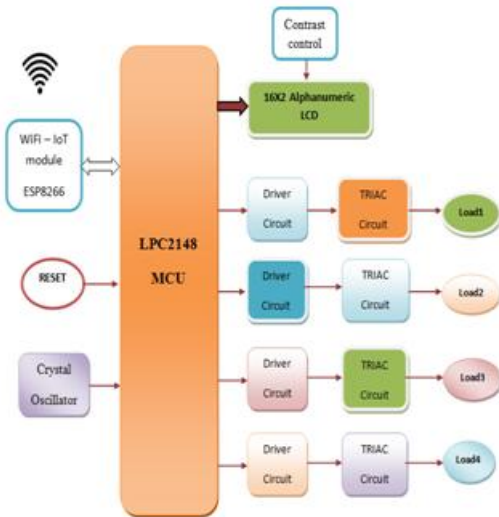

INTERNET OF THINGS

Internet is helping people to communicate each other using different applications

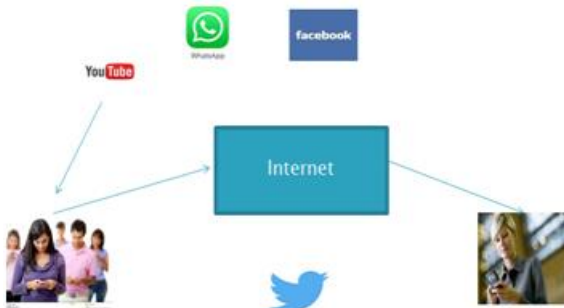

Traffic Light Wants to communicate to other traffic light using internet?

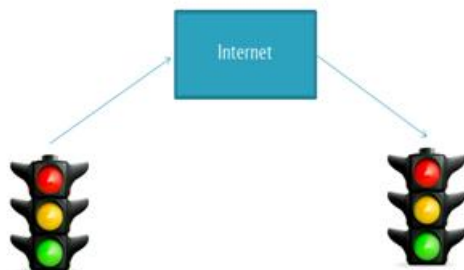

What if I want to communicate Things Each other using Internet?
Internet of things helps the things to communicate each other using IoT module

ESP8266EX

- ▶ The Internet of Things (IoT) is the network of physical objects or "things" embedded with electronics, software, sensors, and network connectivity, which enables these objects to collect and exchange data.



Different Modules

- ▶ ESP8266(ESPRESSIF)
- ▶ ESP8089
- ▶ ESP6203

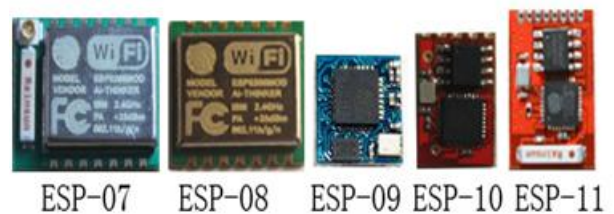

Wi-Fi module

ESP8266EX offers a complete and self-contained WiFi networking solution; it can be used to host the application or to offload WiFi networking functions from another application processor. When ESP8266EX hosts the application, it boots up directly from an external flash.

It has integrated cache to improve the performance of the system in such applications. Alternately, serving as a WiFi adapter, wireless internet access can be added to any micro controller-based design with simple connectivity (SPI/SDIO or I2C/UART interface). ESP8266EX is among the most integrated WiFi chip in the industry; it integrates the antenna switches, RF balun, power amplifier, low noise receive amplifier, filters, power management modules, it requires minimal external circuitry, and the entire solution, including front-end module, is designed to occupy minimal PCB area. ESP8266EX also integrates an enhanced version of Tensilica's L106 Diamond series 32-bit processor, with on-chip SRAM, besides the WiFi functionalities. ESP8266EX is often integrated with external sensors and other application specific devices through its GPIOs; sample codes for such applications are provided in the software development kit (SDK).

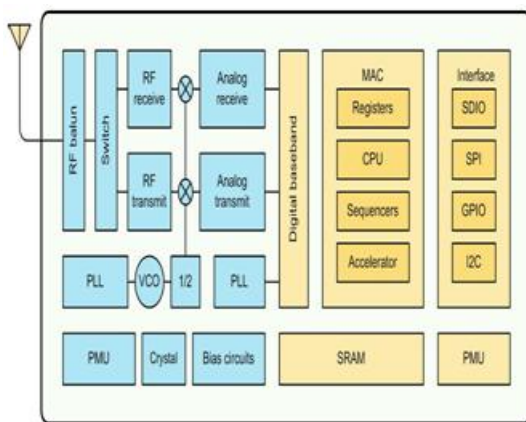

Features

- 802.11 b/g/n
- Integrated low power 32-bit MCU
- Integrated 10-bit ADC
- Integrated TCP/IP protocol stack
- Integrated TR switch, balun, LNA, power amplifier and matching network
- Integrated PLL, regulators, and power management units
- Supports antenna diversity
- Wi-Fi 2.4 GHz, support WPA/WPA2
- Support STA/AP/STA+AP operation modes

- Support Smart Link Function for both Android and iOS devices
- SDIO 2.0, (H) SPI, UART, I2C, I2S, IR Remote Control, PWM, GPIO
- STBC, 1x1 MIMO, 2x1 MIMO
- A-MPDU & A-MSDU aggregation & 0.4s guard interval
- Deep sleep power <10uA, Power down leakage current < 5uA
- Wake up and transmit packets in < 2ms
- Standby power consumption of < 1.0mW (DTIM3)
- +20 dBm output power in 802.11b mode
- Operating temperature range -40C ~ 125C
- FCC, CE, TELEC, Wi-Fi Alliance, and SRRC certified

Pin Definitions

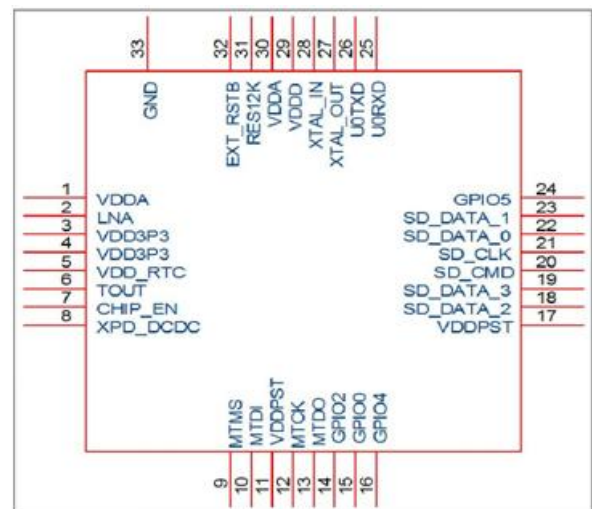

Interfacing with USB UART

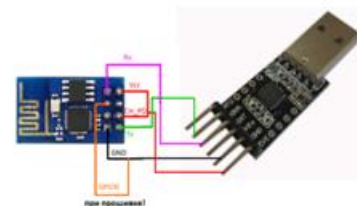

AT commands are used to control MODEMs. AT is the abbreviation for Attention. These commands come from Hayes commands that were used by the Hayes smart modems



Important AT commands

- ▶ **AT+CWLAP** List all the access points
- ▶ **AT+CWJAP?+CWJAP="ssid", "password"** Join Access Point
- ▶ **AT+CIFSR** Get IP Address
- ▶ **AT+CWMODE?+CWMODE=3** Select the respective mode

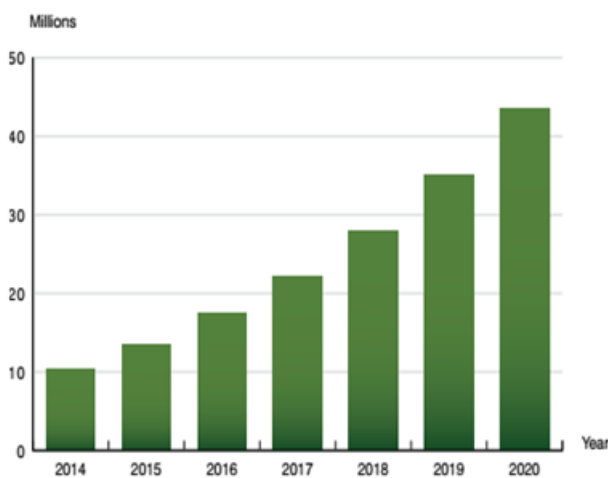

Installed base of active wireless devices in industrial automation (World 2014–2020)

Major fields of **ESP8266EX** applications to Internet-of-Things include:

- Home Appliances
- Home Automation
- Smart Plug and lights
- Mesh Network
- Industrial Wireless Control
- Baby Monitors
- IP Cameras
- Sensor Networks

- Wearable Electronics



Software tools

Keil compiler is a software used where the machine language code is written and compiled. After compilation, the machine source code is converted into hex code which is to be dumped into the microcontroller for further processing. Keil compiler also supports C language code.

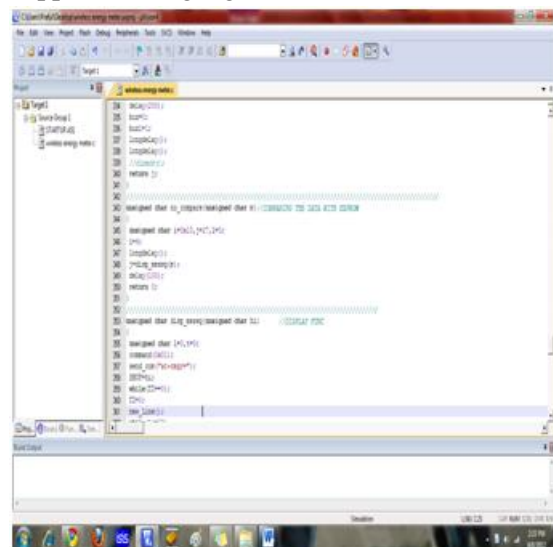

Flash Magic

Flash Magic is a tool which is used to program hex code in EEPROM of micro-controller. It is a freeware tool. It only supports the micro-controller of Philips and NXP. It can burn a hex code into that controller which supports ISP (in system programming) feature. Flash magic supports several chips like **ARM Cortex M0, M3, M4, ARM7 and 8051**.



ADVANTAGES:

- Fit and Forget system
- Low cost and reliable circuit
- Less manpower, accurate output.

APPLICATIONS:

- House hold applications
- Offices, industries ,Shopping malls

CONCLUSION:

This project presents a high sensitive IoT based device control. This project is designed and implemented with LPC2148 in the stream of embedded systems. Experimental work has been carried out carefully. The proposed method is verified to be highly beneficial in all places.

References:

1. “Brownfield innovation” is related to “brownfield development” – a commonly used term in the IT industry to describe the development and deployment of new software in the presence of existing or legacy applications. It means any new software must take into account and coexist with the systems already in place.
2. Gartner, Hyper Cycles Research. 2014. <http://www.gartner.com/technology/research/hype-cycles>.
3. Oxford Economics, <https://www.oxfordeconomics.com/forecastsand-models/industries/data-and-forecasts/global-industry-databank/benefits-and-uses>.
4. Elfrink, Wim. “The Internet of Things: Capturing the Accelerated Opportunity”. Cisco Blog, October 15, 2014.

<http://blogs.cisco.com/ioe/the-internet-of-things-capturing-the-accelerated-opportunity>.

5. Cisco, 2014 IoT World Forum. <http://www.iotwf.com>.
6. GE press release. “GE to Open Up Predix Industrial Internet Platform to All Users”. October 9, 2014. <http://www.genewsroom.com/pressreleases/ge-open-predix-industrial-internet-platform-all-users-278755>.