

Hysteresis Voltage Control Technique in DVR fed Induction Motor Drive



R.Kiran

M.Tech Student Scholar,
Department of Electrical &
Electronics Engineering,
Bv Raju Institute of Technology.



Saleem Pasha

Associate Professor,
Department of Electrical &
Electronics Engineering,
BV Raju Institute of Technology.



Dr.N.Bhoopala, M.E, Ph.D

Professor & HOD,
Department of Electrical &
Electronics Engineering,
BV Raju Institute of Technology.

Abstract:

Dynamic Voltage Restorer (DVR) is a power customized device used in power distribution network. This paper describes the problem of voltage sags and swells and its severe impact on induction motor loads or sensitive loads. The dynamic voltage restorer (DVR) has become popular as a cost effective solution for the protection of sensitive loads from voltage sags and swells.

Power quality is one of the major concerns in the present power system environment. Dynamic Voltage Restorer (DVR) is a modified power apparatus that is utilized to enhance voltage stability i.e. to minimize the power quality problems in electrical power system network.

The proposed control scheme is simple to design and has excellent voltage compensation capabilities. Effectiveness of proposed technique is investigated through computer simulation. To appropriately control the control targets for compensation voltage control, firstly the power circuit of a DVR system is analysed.

The proposed converter connected to induction motor drive to test the speed torque characteristics of induction motor drive and the design is simple. The Simulation results are carried out by Matlab/Simulink to verify the performance of the proposed method.

Key words:

Dynamic Voltage Restorer (DVR), Voltage Sags, Voltage Swells, Sensitive Load, VSI

I.INTRODUCTION:

Power Quality problems encompass a wide range of disturbances such as voltage sags/swells, flicker, harmonics distortion, impulse transient, and interruptions [1]. Voltage sags can occur at any instant of time, with amplitudes ranging from 10 – 90% and a duration lasting for half a cycle to one minute [3]. Voltage swell, on the other hand, is defined as a swell is defined as an increase in rms voltage or current at the power frequency for durations from 0.5 cycles to 1 min. typical magnitudes are between 1.1 and 1.8 up. Swell magnitude is also described by its remaining voltage, in this case, always greater than 1.0. [2,3,4].

Voltage swells are not as important as voltage sags because they are less common in distribution systems. Voltage sag and swell can cause sensitive equipment (such as found in semiconductor or chemical plants) to fail, or shutdown, as well as create a large current unbalance that could blow fuses or trip breakers. These effects can be very expensive for the customer, ranging from minor quality variations to production downtime and equipment damage [5-7]. There are many different methods to mitigate voltage sags and swells, but the use of a custom Power device is considered to be the most efficient method. Switching off a large inductive load or Energizing a large capacitor bank is a typical system event that causes swells [1]. This paper introduces Dynamic Voltage Restorer and its operating principle. Then, a simple control based on dqo method is used to compensate voltage sags/swell. At the end, MATLAB/SIMULINK model based simulated results were presented to validate the effectiveness of the proposed control method of DVR.

Voltage sag is the most severe power quality problem faced by industrial customers. Voltage sag is common reasons for malfunctioning in production plants. Voltage sag is a short term reduction in voltage magnitude. According to IEEE standard 1159 voltage sag is “a decrease in RMS voltage between 10 to 90 % at a power frequency for durations from 0.5 cycles to 1 minute”.

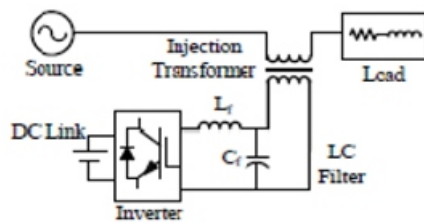

Fig.1. Basic Components of a DVR

During voltage sag, the DVR injects a voltage to restore the load supply voltages. The DVR needs a source for this energy. Two types of system are considered; one using stored energy to supply the delivered power as shown in Figure1, and the other having no internal energy storage. There are a number of voltage sag/swell mitigating methods available but the use of custom power service is considered to be the most efficient method. This paper introduces basic concept of DVR (Dynamic Voltage Restore).

DVR injects an appropriate voltage magnitude with an appropriate phase angle dynamically [4]. Dynamic compensating signals are determined based on the difference between desired and actual values [5]. Main components of DVR are voltage source converter, injecting transformer, passive filter, and energy storage device. The performance of DVR depends on the efficiency control technique of switching of voltage source inverter (VSI). In this paper abc to dq0 based simple control method is used to compensate voltage sag/swell.

II.SYSTEM DISCRPTION:

DVR is a power electronic based device that injects voltage into the system to regulate the load side voltage. It is normally installed between supply and critical load feeder. The basic function of DVR is to boost up the load side voltage in the event of disturbance in order to avoid any power disruption to the load. There are many control techniques available to implement the DVR.

The primary function of DVR is to compensate voltage sags and swells but it can also perform the tasks such as: harmonic compensation, reduction of transient in voltage and fault current limitation. The main parts of DVR are injection transformer, harmonic filter, a voltage source converter, energy storage device and control & protection system.

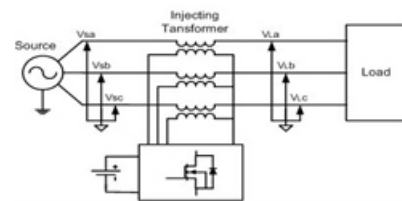

Fig.2. Basic Principle of DVR

Fig.2. shows the basic compensation principle of dynamic voltage restore. A voltage source inverter (VSI) is used as the series active power filter. This is controlled so as to draw or inject a compensating voltage V_{inj} from or to the supply, such that it cancels voltage harmonics on the load side i.e. this dynamic voltage restore (DVR) generates the distortions opposite to the supply harmonics.

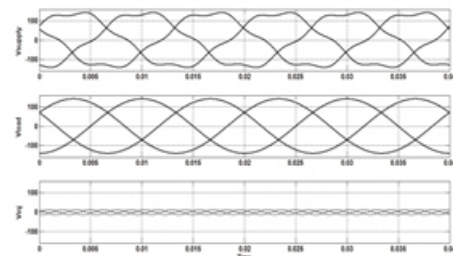

Fig.3. Waveforms for the supply voltage, desired load voltage and the compensating voltage

Fig.3. shows the different waveforms i.e. source voltage, desired load voltage and the compensating voltage injected by the DVR which contains all the harmonics, to make the load voltage purely sinusoidal. This is the basic principle of series active power filter to eliminate the supply voltage harmonics.

III.CONVENTIONAL SYSTEM CONFIGURATION OF DVR:

Dynamic Voltage Restorer is a series connected device designed to maintain a constant RMS voltage value across a sensitive load. The DVR considered consists of:

- a. an injection / series transformer
- b. a harmonic filter,
- c. a Voltage Source Converter (VSC),
- d. an energy storage and
- e. a control system , as shown in Figure.4

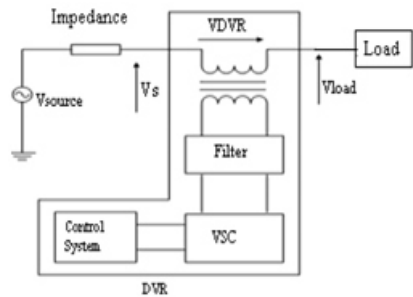

Fig.4 Schematic diagram of DVR

The main function of a DVR is the protection of sensitive loads from voltage sags/swells coming from the network. Therefore as shown in Fig.4, the DVR is located on approach of sensitive loads. If a fault occurs on other lines, DVR inserts series voltage VDVR and compensates load voltage to pre fault value. The momentary amplitudes of the three injected phase voltages are controlled such as to eliminate any detrimental effects of a bus fault to the load voltage VL. This means that any differential voltages caused by transient disturbances in the ac feeder will be compensated by an equivalent voltage generated by the converter and injected on the medium voltage level through the booster transformer. The DVR works independently of the type of fault or any event that happens in the system, provided that the whole system remains connected to the supply grid, i.e. the line breaker does not trip. For most practical cases, a more economical design can be achieved by only compensating the positive and negative sequence components of the voltage disturbance seen at the input of the DVR. This option is Reasonable because for a typical distribution bus configuration, the zero sequence part of a disturbance will not pass through the step down transformer because of infinite impedance for this component.

IV.HYSTERESIS VOLTAGE CONTROL TECHNIQUE:

The control of dynamic voltage restorer is relates with the detection of voltage sag/dip, voltage swell, and the generation of the reference voltages for injection purpose.

The sag, swell detection technique is very important task for the appropriate working of dynamic voltage restorer. There are various techniques for the detection of voltage sag, swell. Some are given below. Measuring peak values of input supply, Measuring of voltage components in dq frame in a vector controller and applying phase locked loop to each phase.

Structure of DVR by using Hysteresis Voltage Control Technique:

Following figure explains the main control diagram of dynamic voltage restorer with hysteresis voltage controller. It mainly consists of three phase IGBT inverter, Energy storage, booster transformer and the hysteresis voltage controller. The hysteresis controller mainly requires two voltage signals, one is from supply side voltage signal and another is from booster transformer which is voltage injected by dynamic voltage restorer. The controller compares these two signals and according to these signals switching pattern is established. The hysteresis switching method is well explained in fig.5.

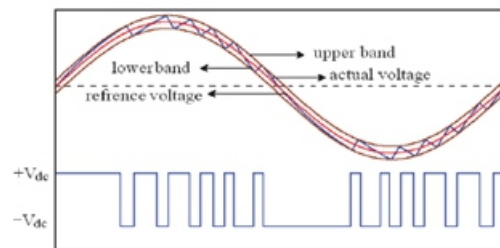

Fig.5 Hysteresis switching pattern

Z-source inverter has X-shaped impedance network on its DC side, which interfaces the source and inverter H-bridge. It facilitates both voltage-buck and boost capabilities. The impedance network composed of split inductors and two capacitors. The supply can be DC voltage source or DC current source or AC source. Z-source inverter can be of current source type or voltage source type. Fig. 3 shows the general block diagram of Z-Source inverter voltage.

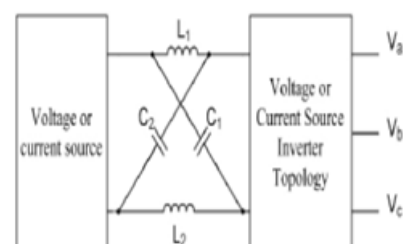

Fig. 6 General Block Diagram of Z-Source Inverter

Z-Source inverter operation is controlled by multiple pulse width modulation. The output of the Z-Source inverter is controlled by using pulse width modulation, generated by comparing a triangular wave signal with an adjustable DC reference and hence the duty cycle of the switching pulse could be varied to synthesize the required conversion. A stream of pulse width modulation is produced to control the switch as shown in the Figure 7.

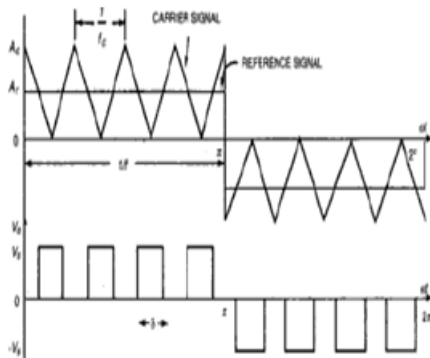

Fig. 7 Multiple Pulse Width Modulation

As shown in Table I, the single-phase Z-Source inverter has five switching modes. Two active modes in which the dc source, voltage is applied to load, two zero modes in which the inverter's output terminals are short circuited by S1 and S3 or S2 and S4 switches and a shoot-through mode which occurs as two switches on a single leg are turned on.

TABLE I SWITCHING MODES

S ₄	S ₃	S ₂	S ₁	Switching mode
1	0	0	1	Active mode
0	1	1	0	
0	1	0	1	Zero mode
1	0	1	0	
0 or 1	0 or 1	1	1	Shoot-through mode

Applying a distinctive PWM method is necessary for ZSI considering the defined operational modes. In a symmetric impedance network, the following equations are valid:

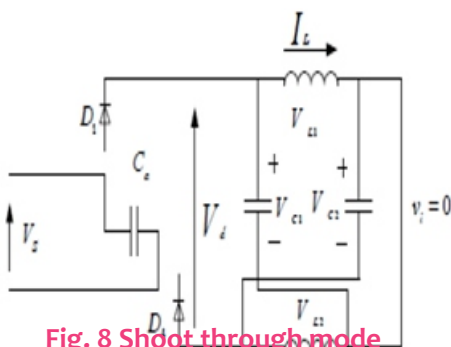

Fig. 8 Shoot through mode

V.SIMULATION RESULTS:

Here the simulation results are carried by three different cases 1) Sag and Swell compensation by DVR 2) Swell compensation by DVR 3) Sag compensation by DVR applied to induction motor drive

Case-1 Sag and Swell compensation by DVR

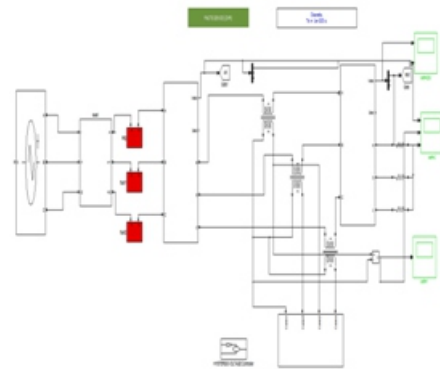

Fig.9 Matlab/Simulink model of fault and Sag generation and mitigated by DVR.

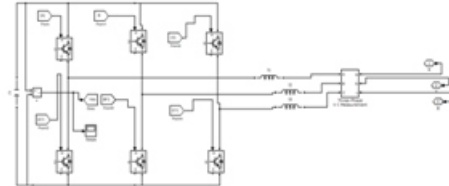

Fig.10 Matlab/Simulink model of the DVR.

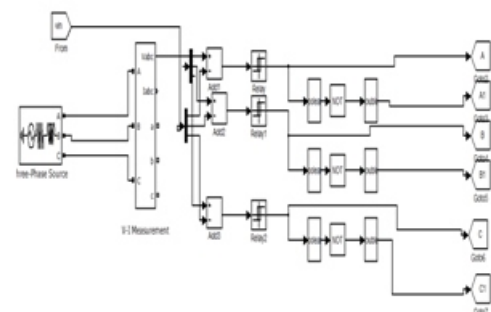

Fig.11 Hysteresis Voltage Controller.

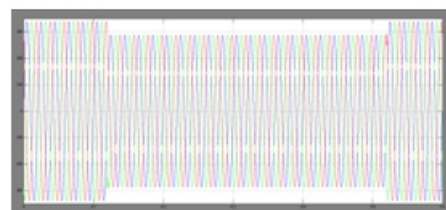

Fig.12 Simulated output wave forms of the source voltage due to the fault and the sag appeared on the source side from 0.1 sec to 0.5 sec dip in magnitude of the source voltage.

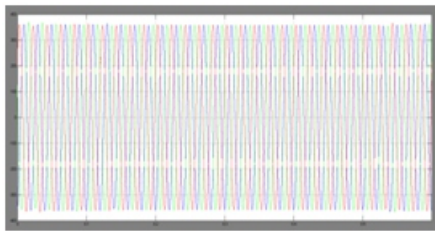

Fig.13 Simulated output wave form of Load voltage

Even there is fault and sag appeared from the source side due the presence of the DVR load voltage is maintained constant.

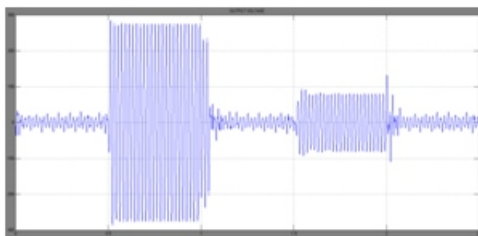

Fig.14 Simulated output wave form the Compensating voltages generated by the DVR.

Case-2 Swell compensation by DVR:

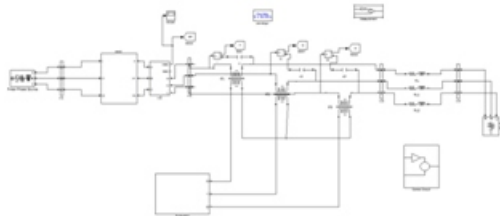
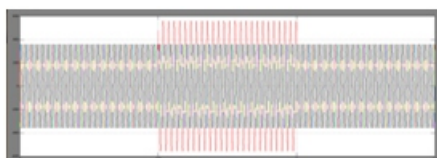

Fig.15 Matlab/Simulink model of fault and Swell generation and mitigated by DVR



Simulated output wave forms of the source voltage due to the fault and the Swell appeared on the source side from 0.1 sec to 0.5 sec.

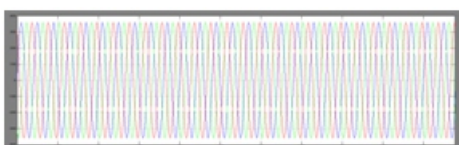

Fig.17 Simulated output wave form of Load voltage

Even there is fault and sag appeared from the source side due the presence of the DVR load voltage is maintained constant.

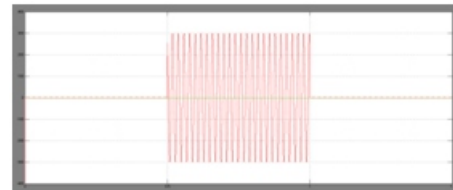

Fig.18 Simulated output wave form the Compensating voltages generated by the DVR

Case-3 Sag compensation by DVR applied to induction motor drive:

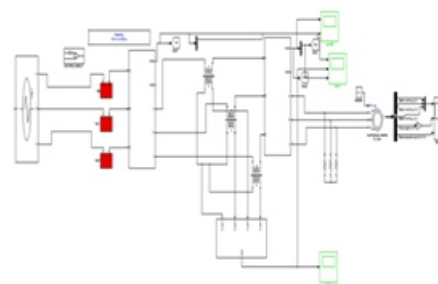

Fig. Matlab/simulink model of proposed converter with induction motor drive as load

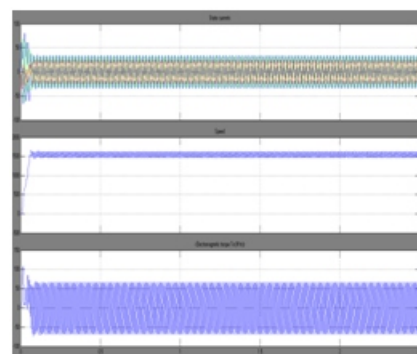

Fig. simulated output waveform of speed torque characteristics of induction motor drive

VI.CONCLUSION:

In this paper voltage sag compensation using Dynamic Voltage Restorer is considered. It is observed that throughout fault condition the power factor at input side is maintained unity and the system output voltage is maintained constant throughout the fault condition. The simulation results show that the developed control technique with proposed single phase DVR is simple and efficient..

Many industries consist of large number of power electronics devices and energy resourceful apparatus these are more susceptible to the unbalance in the input supply voltage. Now a day these issues of power quality are very important for customer and utility also. So for this custom power device, Dynamic Voltage Restorer (DVR) is used to mitigate these power quality problems, also it shows that the hysteresis voltage control technique is very good technique for dynamic voltage restorer as it plays an important role in mitigation of voltage sag, The control technique is designed using in-phase compensation and used a closed loop control system to detect the magnitude error between voltages during pre-sag and sag periods. The modeling and simulation of closed loop control of voltage sag/swell mitigation were carried out using MATLAB software.

REFERENCES:

- [1] N.G. Hingorani, "Introducing Custom Power in IEEE Spectrum," 32p, pp. 41-48, 1995.
- [2] IEEE Std. 1159 – 1995, "Recommended Practice for Monitoring Electric Power Quality".
- [3] P. Boonchiam and N. Mithulanathan, "Understanding of Dynamic Voltage Restorers through MATLAB Simulation," Thammasat Int. J. Sc. Tech., Vol. 11, No. 3, July-Sept 2006.
- [4] J. G. Nielsen, M. Newman, H. Nielsen, and F. Blaabjerg, "Control and testing of a dynamic voltage restorer (DVR) at medium voltage level," IEEE Trans. Power Electron. vol. 19, no. 3, p.806, May 2004.
- [5] A. Ghosh and G. Ledwich, "Power Quality Enhancement Using Custom Power Devices," Kluwer Academic Publishers, 2002.
- [6] S. Chen, G. Joos, L. Lopes, and W. Guo, "A nonlinear control method of dynamic voltage restorers," in 2002 IEEE 33rd Annual Power Electronics Specialists Conference, 2002, pp. 88- 93.
- [7] R. Buxton, "Protection from voltage dips with the dynamic voltage restorer," in IEE Half Day Colloquium on Dynamic Voltage Restorers Replacing Those Missing Cycles, 1998, pp. 3/1- 3/6.
- [8] H. Awad, J.Svensson, M. Bollen, "Mitigation of Unbalanced Voltage Dips Using Static Series Compensator", IEEE Trans. On Power Elec., Vol. 19, No. 13, May 2004 .
- [9] B. Singh, A. Adya, J. Gupta, "Power Quality Enhancement with DSTATCOM for small Isolated Alternator feeding Distribution System" Power Electronics, And Drive System 2005, (PEDS 2005), Vol1., 16-18 Jan Pages: 274-279.
- [10] Nielsen, Newman, H. Nielsen, and F. Blaabjerg, "Control and testing of a dynamic voltage restorer (DVR) at medium voltage level," IEEE Trans. Power Electronics. vol. 19, no. 3, pp. 806–813, May 2004.
- [11] J. G. Nielsen, "Design and Control of a Dynamic Voltage Restorer," Ph.D. dissertation, Institute of Energy Technology, Aalborg Univ., Aalborg, Denmark, 2002.
- [12] Boonchiam P, and Mithulanathan N, "Understanding of Dynamic Voltage Restorers through MATLAB Simulation". Thammasat Int. J. Sc. Tech., Vol. 11, No. 3, July-Sept 2006.
- [13] Yusuf K: "Industrial power quality problems Electricity Distribution. IEEE Conf. Pub1 No. 482, Vol: 2, 18–21 June 2001 Pages: 5 pp. v01.2.
- [14] Fawzi AL Jowder, "Modeling and Simulation of Dynamic Voltage Restorer (DVR) Based on Hysteresis Voltage Control" The 33rd Annual Conference of the IEEE Industrial Electronics Society (IECON) Nov. 5-8, 2007, Taipei, Taiwan.
- [15] Benachaiba Chellali, FERDI Brahim, "Voltage Quality Improvement Using DVR," Electrical Power Quality and Utilizations, Journal Vol. XIV, No. 1, 2008.
- [16] M. Bollen. "Understanding Power Quality Problems, voltage sags and Interruptions." IEEE press, 1999.