

Enhancement of Performance of PFC Bridgeless Buck-Boost Converter For BLDC Drive By Using Fuzzy PID Controller

Mallikharjuna Rao Boda

M.Tech Student Scholar,

**Department of Electrical & Electronics Engineering,
Baba Institute Of Technology and Sciences,
P.M.Palem, Visakhapatnam(Dt),
Andhra Pradesh, India.**

E.Anil Kumar

Assistant Professor,

**Department of Electrical & Electronics Engineering,
Baba Institute Of Technology and Sciences,
P.M.Palem, Visakhapatnam(Dt),
Andhra Pradesh, India.**

Abstract:

This paper shows another PFC bridgeless (BL) buck-boost converter for brushless direct current (BLDC) engine drive application in low-control applications. A Fuzzy logic execution in adaptable speed control of BLDC engine is done here. A methodology of rate control of the BLDC engine by controlling the dc bus voltage of the voltage source inverter (VSI) is utilized with a solitary voltage sensor. The controller is intended to track varieties of pace references and settles the yield velocity amid burden varieties. The BLDC has a few preferences contrast with the other kind of engines; however the nonlinearity of the BLDC engine drive attributes, in light of the fact that it is hard to handle by utilizing customary relative basic (PI) controller. So as to tackle this fundamental issue, the Fuzzy logic control turns into a suitable control.

To give an inborn PFC at supply ac mains a converter based on buck-boost type is intended to work in broken inductor current mode (DICM). The execution of the proposed commute is mimicked in MATLAB/Simulink environment. Therefore, the overall objective of this project is effectively driving a PFC bridgeless buck-boost converter fed BLDC motor with a combination of hall sensor and electronic commutation which is given to switching of VSI for controlled speed response, furthermore to obtain optimum drive performance and to reduce total harmonic distortion (THD) the fuzzy PID controller is implemented in place of PI controller.

I. INTRODUCTION:

Since 1980's a new plan idea of changeless magnet brushless engines has been created. The Changeless magnet brushless engines are ordered into two sorts based upon the back EMF waveform, brushless Air conditioning (BLA C) and brushless DC (BLDC) engines [2].

BLDC engine has trapezoidal back EMF and semi rectangular current waveform. BLDC engines are quickly getting to be well known in businesses, for example, Appliances, HVA C industry, restorative, electric footing, car, airplanes, military gear, hard plate drive, mechanical computerization gear and instrumentation due to their high effectiveness, high power element, noiseless operation, minimized, dependability and low support [3]. To supplant the capacity of commutators and brushes, the BLDC engine requires an inverter and a position sensor that distinguishes rotor position for legitimate substitution of current. The revolution of the BLDC engine is in light of the criticism of rotor position which is gotten from the corridor sensors.

BLDC engine ordinarily employments three lobby sensors for deciding the recompense Grouping. In BLDC engine the force misfortunes are in the stator where warmth can be effectively exchanged through the edge or cooling frameworks are utilized as a part of expansive machines. BLDC engines have numerous focal points over DC engines and prompting engines. A percentage of the favorable circumstances are better speed versus torque qualities, high element reaction, high proficiency, long working life, quiet operation; higher pace ranges [4].

Up to now, more than 80% of the controllers are PI (Relative and vital) controllers on the grounds that they are effortless and straightforward. The velocity controllers are the routine PI controllers and current controllers are the P controllers to accomplish superior commute. Fuzzy Logic can be considered as scientific hypothesis joining multi esteemed rationale, likelihood hypothesis, and counterfeit consciousness to recreate the human approach in the arrangement of different issues by utilizing an estimated thin king to relate diverse information

sets and to make choices. It has been accounted for that fluffy controllers are more powerful to plant parameter changes than traditional PI or controllers and have better clamor dismissal capacities .This paper presents a BL buck–boost converter fed BLDC motor drive with variable dc link voltage of VSI for imp roved power quality at ac mains with reduced components and superior control

II. PRINCIPLE OF BLDC MOTOR:

BLDC engine comprises of the perpetual magnet rotor and an injury stator. The brushless engines are controlled utilizing a three stage inverter. The engine obliges a rotor position sensor for beginning and for giving legitimate compensation arrangement to turn on the force gadgets in the inverter extension. In light of the rotor position, the force gadgets are commutated consecutively every 60 degrees. The electronic compensation takes out the issues connected with the brush and the commutator plan, in particular starting and destroying of the commutator brush course of action, along these lines, making a BLDC engine more rough contrasted with a dc engine. Fig.1 demonstrates the stator of the BLDC engine and fig.2 shows rotor magnet plans.



Fig.1 BLDC motor stator construction



Fig.2 BLDC motor Rotor construction

The brush less dc engine comprise of four fundamental parts Power converter, changeless magnet brushless DC Motor (BLDCM), sensors and control calculation. The force converter changes power fro m the source to the BLDCM which thus changes over electrical vitality to mechanical vitality. One of the remarkable highlights of the brush less dc engine is the rotor position sensors, in view of the rotor position and order signals which may be a torque charge, voltage summon, rate order etc; the control calculation s focus the entryway sign to every semiconductor in the force electronic converter.

The structure of the control calculations decides the sort of the brush less dc engine of which there are two principle classes voltage source based drives and current source based drives. Both voltage source and current source based commute utilized for perpetual magnet brushless DC machine. The back emf waveform of the engine is demonstrated in the fig. 3. Be that as it may, machine with a non sinusoidal back emf brings about diminishment in the inverter size and lessens misfortunes for the same influence level.

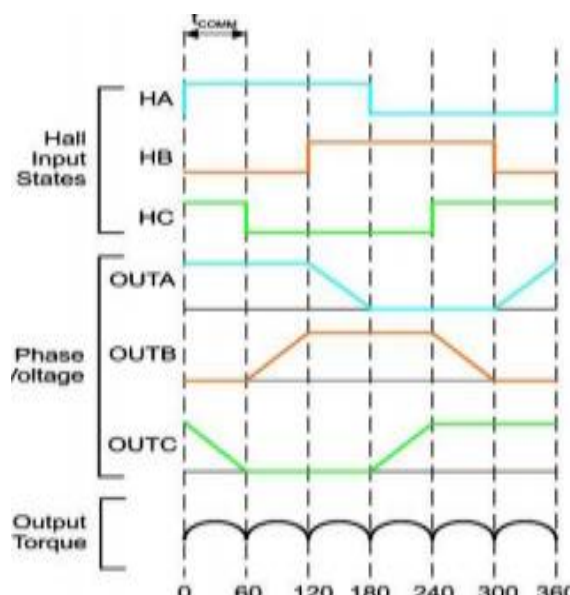

Fig.3 Hall signals & Stator voltages

III. PROPOSED SYSTEM:

The proposed BL buck–boost converter based VSI fed BLDC motor drive is shown in fig.4.

The parameters of the BL buck–boost converter are made such that it operates in discontinuous inductor current mode (DICM) to attain an inherent power factor correction at ac mains. The speed control of BLDC motor is accomplished by the dc link voltage control of VSI using a BL buck–boost converter. This reduces the switching losses in VSI because of the low frequency operation of VSI for the electronic commutation of the BLDC motor.

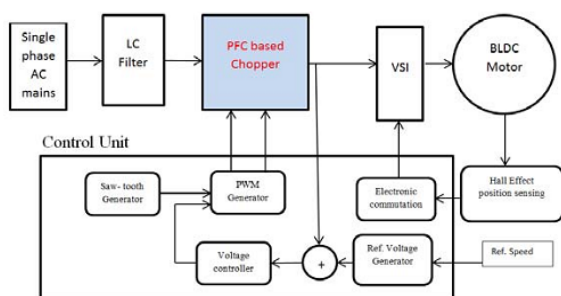

Fig. 4. Block diagram of PFC chopper-fed BLDC motor drive

In the proposed arrangement of bridgeless buck help converter has the base number of parts and slightest number of conduction gadgets amid every half cycle of supply voltage which administers the decision of BL buck boost converter for this application. The operation of the PFC bridgeless buck-help converter is ordered into two parts which incorporate the operation amid the positive and negative half cycles of supply voltage and amid the complete exchanging cycle.

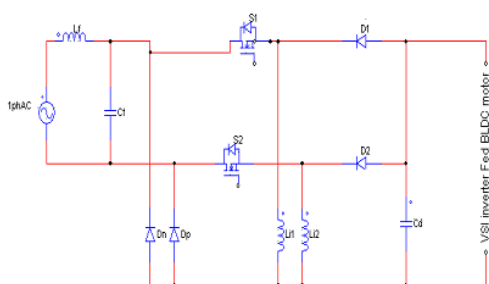

Fig. 5. Proposed Circuit diagram of the Buck-boost converter fed BLDC

A. Operation During Positive and Negative Half Cycle of Supply Voltage:

In this mode converter switches Sw1 and Sw2 are work in positive and negative half cycle of supply voltage individually.

A mid positive half cycle switch SW1, inductor Li1 and diodes D1 and D2 are worked to exchange vitality to DC join capacitor Cd. Thus in negative half cycle of supply voltage switches Sw2, inductor Li2 and diode D2 In Irregular Inductor Current Mode(DICM) operation of converter the present in the inductor Li gets to be irregular for certain term in an exchanging period.

B. Operation During Complete Switching Cycle:

In this exchanging cycle there are three methods of operation.

Mode I:

In this mode, switch Sw1 conducts for charging the inductor Li1, thus the inductor current iLi1 increments in this mode. Diode D 1 finishes the information side and the DC join capacitor Cd is released by VSI nourished BLDC engine

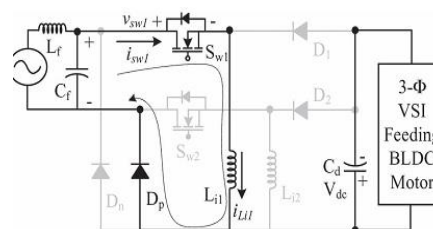

Fig.6. mode 1 operation

Mode II:

In this method of operation switch Sw1 is killed furthermore, the put away vitality from the inductor Li1 is exchanged to DC join capacitor Cd till the inductor is completely released furthermore, current in the inductor is completely lessened to zero.

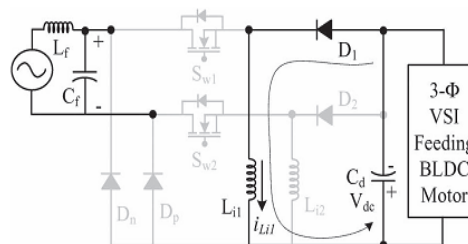

Fig.7. mode 2 operation

Mode III:

In this method of operation inductor L_{i1} work in intermittent conduction mode and diodes and switch are in off condition. As of now DC jo in capacitor C_d begins releasing. This operation can be proceed up to switch $Sw1$ is turned on once more.

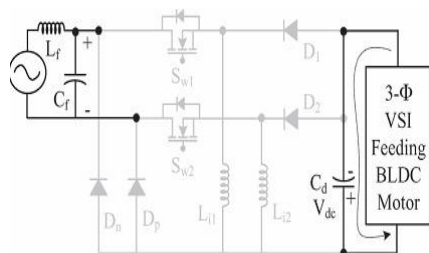

Fig.8. mode 3 operation

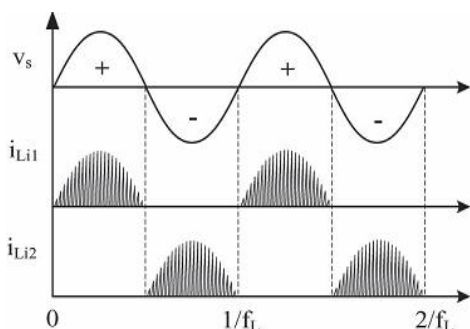

Fig.9. Waveforms for positive and negative half cycles of supply voltage.

Similarly, for the negative half cycle of the supply voltage, switch $Sw2$, inductor $Li2$, and diodes Dn and $D2$ operate for voltage control and PFC operation.

IV. PROPOSED FUZZY LOGIC CONTROLLER:

The control framework is in light of fuzzy logic. FL controller is an one sort non straight controller and programmed. Th is kind of the control drawing closer the human thinking that makes the utilization of the acknowledgement, vulnerability, imprecision and fluffiness in the choice making procedure, figures out how to offer an exceptionally tasteful execution, without the need of a definite numerical model of the framework, just by fusing the specialists' learning into the fluffy. Fig 6 demonstrates the FL controller piece outline. This fluffy rationale control framework is in view of the MAMDHANI fluffy model.

This framework comprises of four principle parts. To begin with, by utilizing the info enrollment capacities, inputs are Fuzzified then in view of standard bases and the inferencing framework, yields are delivered lastly the fluffy yields are Defuzzified and they are connected to the principle control framework.

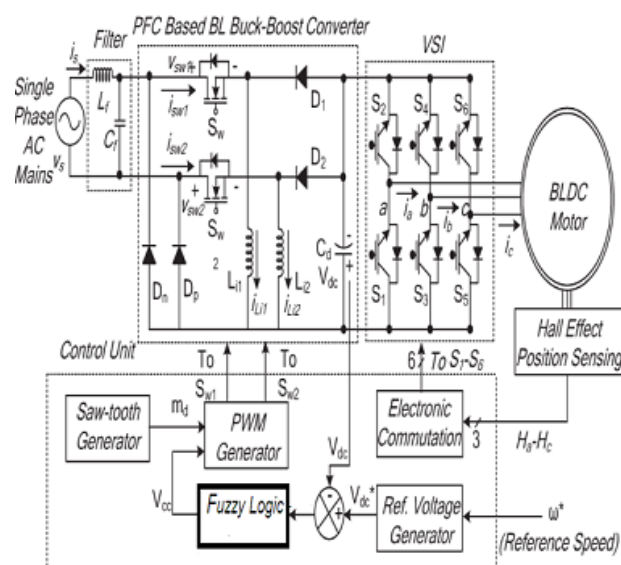

Fig 10. Extension circuit diagram DC-DC converter & BLDC motor with fuzzy controller.

Error of inputs from their references and error deviations in any time interval are chosen as MATLAB. The output of fuzzy controller is the value that should be added to the prior output to produce new reference output.

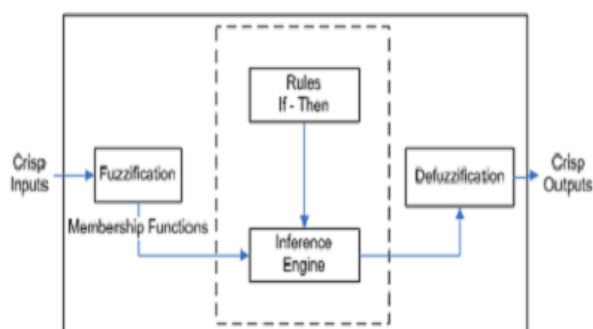

Fig.11. Block Diagram of fuzzy logic controller

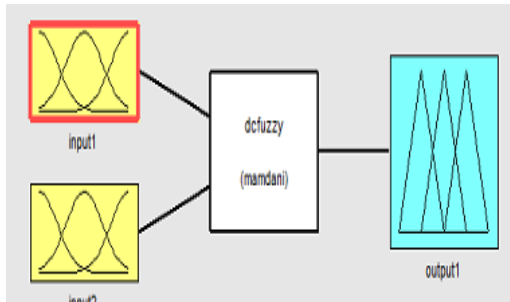

Fig 12. selection of input and output variables

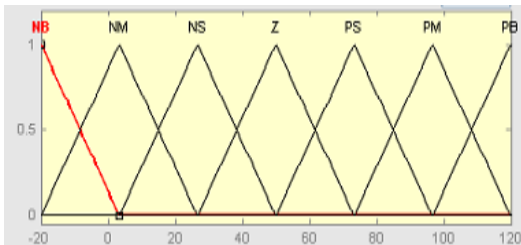

Fig 13. Input1 membership function

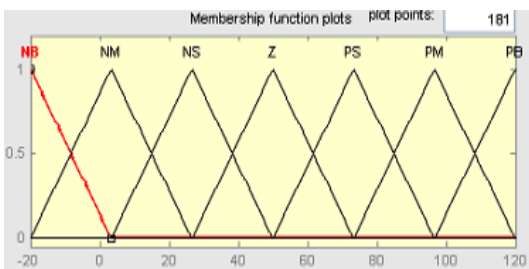

Fig.14 Input 2 membership function

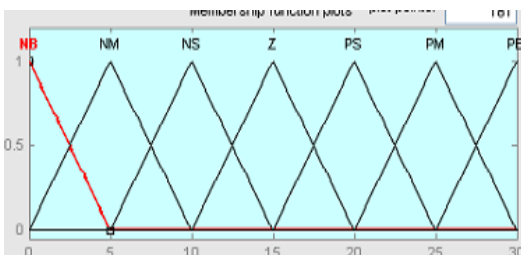

Fig.15.Output membership function

V. MATLAB/SIMULINK RESULTS

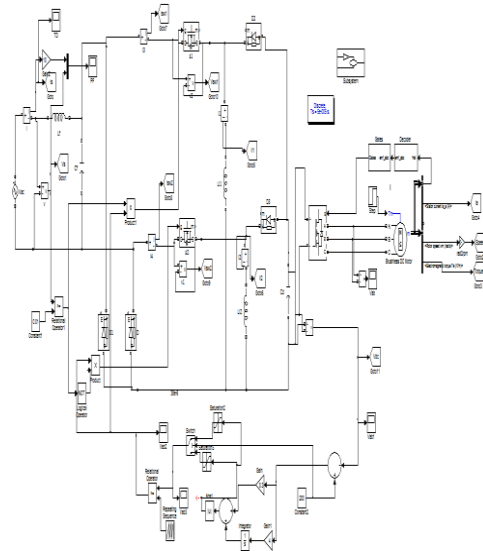

Fig.16.Simulink circuit for proposed BLDC drive with bridgeless buck boost converter with PI controller

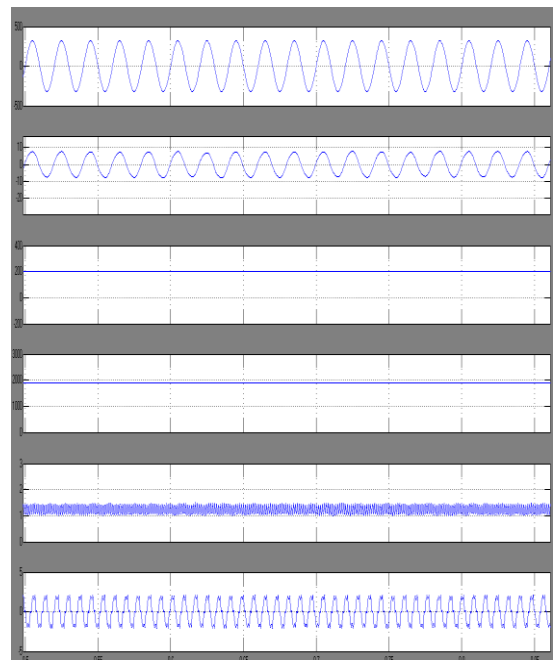

Fig.17.Simulation results for source voltage, current, dc link voltage, and speed , torque, stator current of BLDC motor under steady state performance

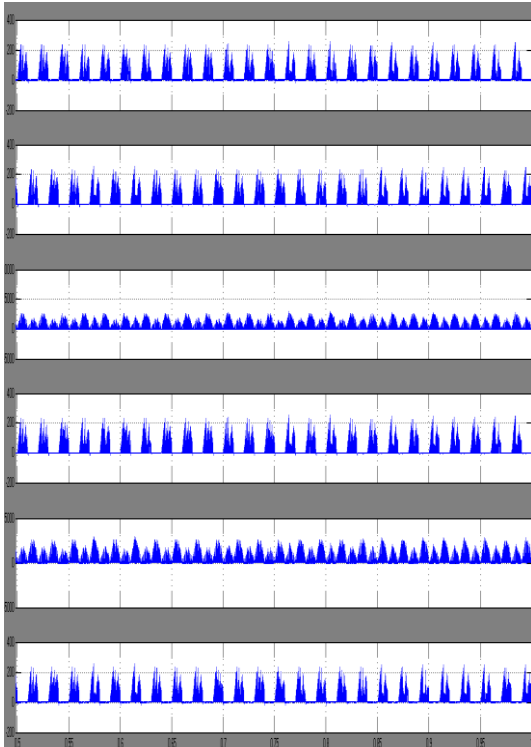

Fig.18.Simulation results for i_{Li1} , i_{Li2} , V_{sw1} , i_{sw1} , V_{sw2} , i_{sw2} of PFC converter under steady state performance

Fig.19.Simulation result of proposed system under dynamic performance during starting condition

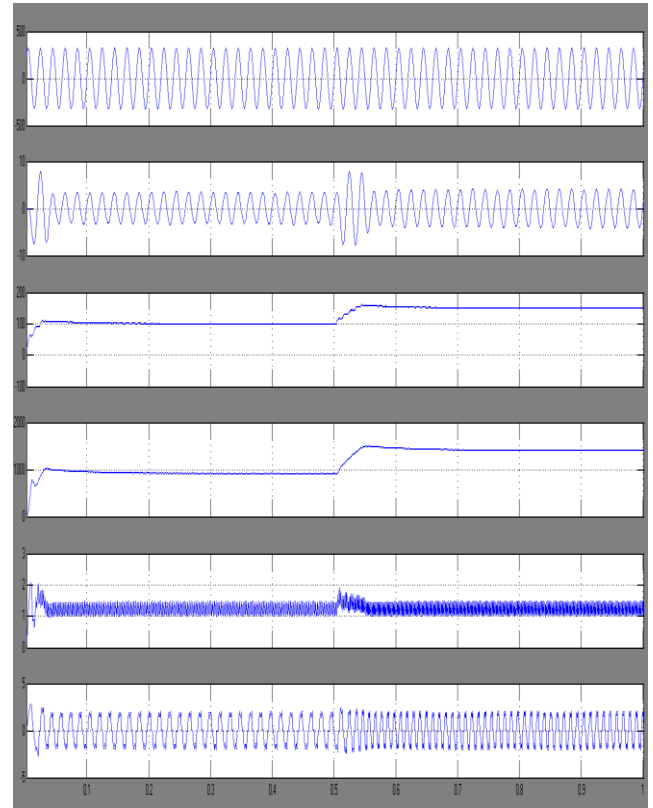

Fig.20.Simulation result of dynamic performance of proposed system during Step voltage variation.

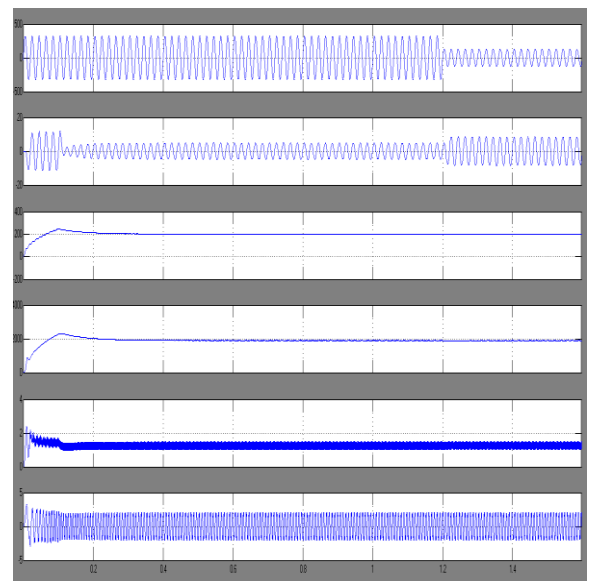
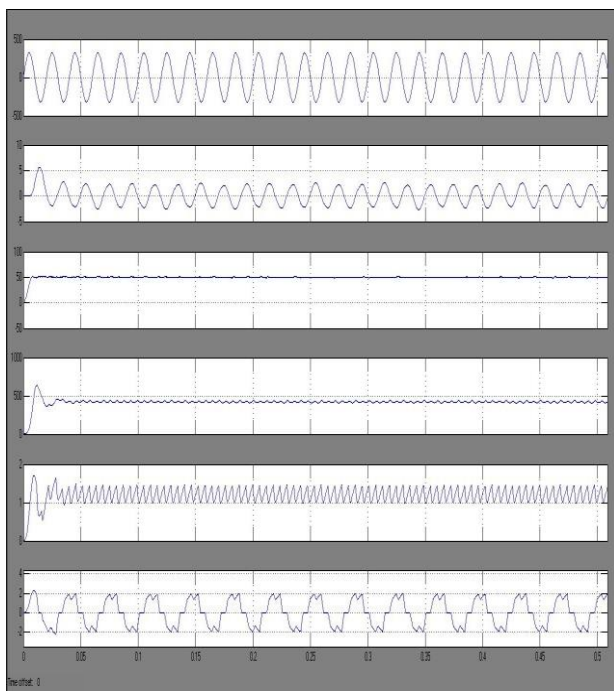

Fig.21.Simulation result of dynamic performance of proposed system during supply voltage variation

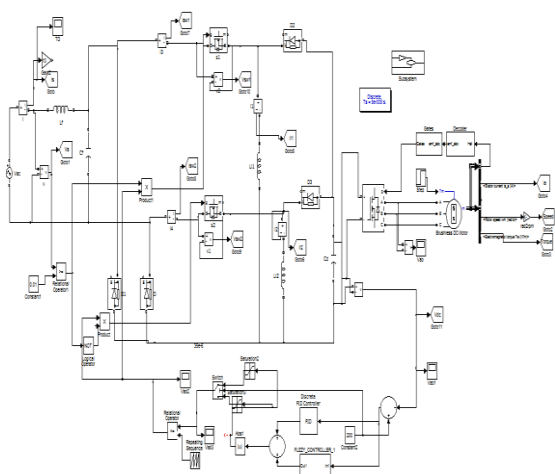

Fig.22.Simulink circuit for proposed system by using fuzzy controller

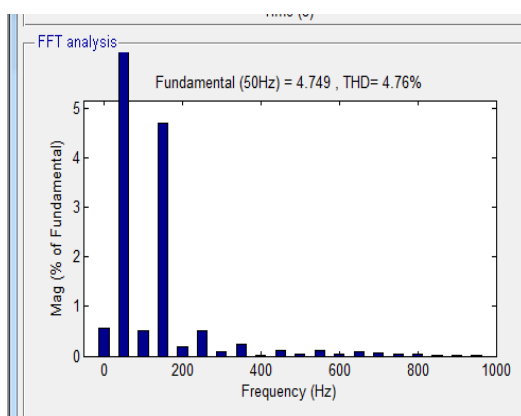

Fig.23.FFT analysis by using PI controller

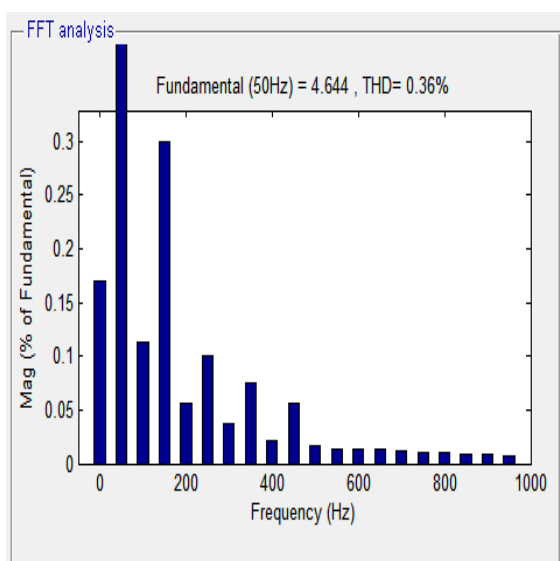

Fig.24.FFT analysis by using fuzzy controller

VI. CONCLUSION:

The dynamic characteristics of the brushless DC motor such as speed, torque, current and voltage of the inverter components are observed and analyzed using the developed MATLAB model. Proposed fuzzy logic controller system has a good adaptability and strong robustness whenever the system is disturbed. The simulation model which is implemented in a modular manner under MATLAB environment allows dynamic characteristics such as phase currents, rotor speed, and mechanical torque to be effectively considered.

REFERENCES:

- [1].Vashist Bist, and Bhim Singh, An Adjustable-Speed PFC BridgelessBuck–Boost Converter-Fed BLDC Motor Drive, IEEE Transactions on Industrial Electronics, VOL. 61, NO. 6, JUNE 2014.
- [2].G. Sakthival, T.S. Anandhi and S.P. Natarjan. 2010. Real time implementation of DSP based Fuzzy logic controller for Speed control of BLDC motor. International Journal of Computer Applications (0975 - 8887). 10(8).
- [3]. K. Naga Sujatha, K. Vaisakh and Anand. G. 2010. Artificial Intelligence based speed control of brushless DC motor. IEEE 978- 1- 4244- 6551-4/10.
- [4].2003. AN885 - Brushless DC (BLDC) Motor Fundamentals. Microchip Technology Inc.
- [5].R. Akkaya, A.A. Kulaksız, and O Aydogdu, DSP implementation of a PV system with GA - MLP- NN based MPPT controller supplying BLDC motor drive, Energy Conv. and Management 48, 210 -218, 2007.
- [6].P. Pillay and R. Krishnan, Modeling, simulation, and analysis of permanent -magnet motor drives, part II: the brushless DC motor drive, IEEE Trans. on Industry Applications 25, 274–279, 1989.
- [7].P.D. Evans and D. Brown, Simulation of brushless DC drives, Proc. of the IEE 137, 299– 308, 1990.
- [8].R. Carlson, M. Lajoie -Mazenc, and C.D.S. Fagundes, Analysis of torque ripple due to phase commutation in brushless DC machines, IEEE Trans. on Industry Applications 28, 632–638, 1992.