

## HVDC Transmission Using Artificial Neural Networks Based Constant Current and Extension Angle Control

V. Chandra Sekhar

Department of Electrical and Electronics Engineering,  
Andhra University College of Engineering,  
Visakhapatnam, Andhra Pradesh -530003, India.

### Abstract

*Long distance AC transmission is often subjected to certain problems which limit the transmission capability. HVDC is a better option for transmission of power over long distances. Power is being transmitted between two generating stations via dc link. The control of power flow in DC link can be achieved through control of current or voltage. For minimization of loss considerations it is important to maintain constant voltage in link and adjust current to meet required power. In this project, a HVDC system is designed to control the power flow between two converter stations with conventional PI controller and Artificial Neural Networks. For rectifier side current control is used for inverter side both current and extinction angle control is implemented. The error signal is passed through a PI and Artificial Neural Networks controller, which produces the necessary firing angle order. The firing circuit uses this information to generate the equidistant pulses for the valves in the converter station. Here Artificial Neural Networks is designed for both rectifier and inverter control and its performance is compared with conventional PI controller.*

**Keywords—** HVDC Transmission, Simulation, Artificial neural networks, Conventional controller.

### I. Introduction

The traditional HVDC classic technology [1] is used to transmit power for long distances via overhead lines or submarine cables with reduced losses. There is a breakpoint between ac and dc transmission distance, where after this point dc transmission is smarter and

efficient. It also reduces the synchronous constraints between the two ac systems. It enhances steady state and dynamic stability of the ac system. In recent 15 years a new technology, HVDC Light based on VSC (Voltage Source Converters) [2] is used. HVDC Light has considerably higher dynamic performance compared to HVDC Classic, but still HVDC Classic is dominating for low cost bulk transmission. In accordance with operational requirements, flexibility and investment HVDC transmission systems are classified into two-terminal and multi terminal. The first HVDC transmission in the world has begun in 1954. It was 150KV, 20MW DC link between Swedish main land and island of Gotland by ASEA.

Until 1970, mercury valves are used for conversion of direct current. After a powerful invention of high power electronic device so called thyristor for static power transfer has been encouraged by power industries and its substantial increase of rating and reliability over the years. High and growing electricity demands needs the transmission of electrical power over long distances. Right-of way (ROW) and better efficiency are some of the challenges that have faced by the power transmission industry over the years. High Voltage Direct Current (HVDC) technology is mainly used in long distances and it is gaining popularity over ac technology in this contest.

**Cite this article as:** V. Chandra Sekhar, "HVDC Transmission Using Artificial Neural Networks Based Constant Current and Extension Angle Control", International Journal & Magazine of Engineering, Technology, Management and Research, Volume 5 Issue 3, 2018, Page 60-66.

The modern form of HVDC employs the technology that was developed and commercialized some 50 years ago by ABB (Asea Brown Boveri) company. DC power transmission at low voltages has high losses over long distances, thus giving rise to High Voltage Alternating Current (HVAC) electrical systems [3]. It was realized that for an ac system voltage conversion is simple with the development of a high power transformer. Further, a three phase synchronous generator is superior to a dc generator in every aspect. For these reasons ac technology was introduced at very early stage in the development of electrical power systems and it was soon accepted as the only feasible method of generation, transmission and distribution of electrical energy. However, some shortcomings in the HVAC transmission technology led to research into the application of HVDC transmission systems. With the development of high voltage valves, it became possible to transmit dc power at high voltages and over long distances, giving rise to HVDC transmission systems [4]. This has grown tremendously in the recent years due to the fast development of modern solid state power electronic. For bulk power transmission over land, the most frequent HVDC transmission line is used.

This overhead line is normally bipolar, i.e. two conductors with opposite polarities. HVDC cables are normally used for submarine transmission. The most common types of cables are the solid and the oil-filled ones. The solid type, where the insulation consists of paper tapes impregnated with high viscosity oil, is in many cases the most economic one. No length limitation exists for this type and designs are now available for depths up to 1000 m. The self - contained oil-filled cable is completely filled with low viscosity oil and always works under pressure. The adopted design criteria for HVDC insulation is the based on the recommendations of IEC 60815. This standard was initially designed for ac lines and it has to be observed that the creepage distances recommended are based on the phase-to-phase voltage. When transferring these creepage distances recommended by IEC 60815 to a dc line, it has to be

observed that the dc voltage is a peak-to-ground. Therefore, the creepage distance has to be multiplied with factor  $\sqrt{3}$ . Insulators operated under dc voltage are also subjected to more unfavourable conditions compared to ac voltages due to higher collection of surface contamination caused by the unidirectional electric field.

In a dc system, over voltages will occur at inverters, rectifiers and transmission lines during converter starting and shutting down operations, etc. The over voltages caused by those activities are referred to as internal over voltages. There are also external overvoltage's caused by lightning and switching. Lightning strikes pose a great danger to insulation. Although there are shielding systems that protect power systems against lightning strikes, direct strikes are still possible. Most lightning problems however, come through indirect strikes. Long lines are exposed to overvoltages induced by internal and external phenomena.

An HVDC transmission system consists of three basic parts:

- 1) A rectifier station to convert AC to DC
- 2) A DC transmission line and
- 3) An inverter station to convert DC back to AC.

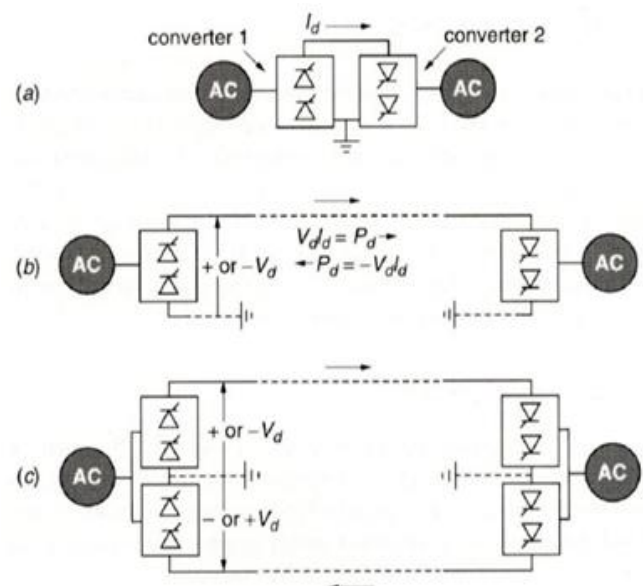

Fig 1. Schematic diagram of an HVDC back to back system system

**II. CONVERTER STATION**

A converter station consists of basic converter unit, which primarily contains converter valve, converter transformer, smoothing reactor, AC filter, DC filter and so on. Basic converter units can be classified into 6-pulse converter unit and 12-pulse converter unit. Usually most HVDC schemes employ the 12-pulse converter as the basic converter unit. In order to form a 12-pulse converter unit, two 6-pulse converter units are connected in series on the DC side and in parallel on the AC side [5]. AC/DC filters can be configured in accordance with the requirements of 12-pulse converter, there by greatly simplifying the number of filters, reducing land use and lowering the cost. A 12-pulse converter unit can employ the converter transformer of either two-winding or three-winding.

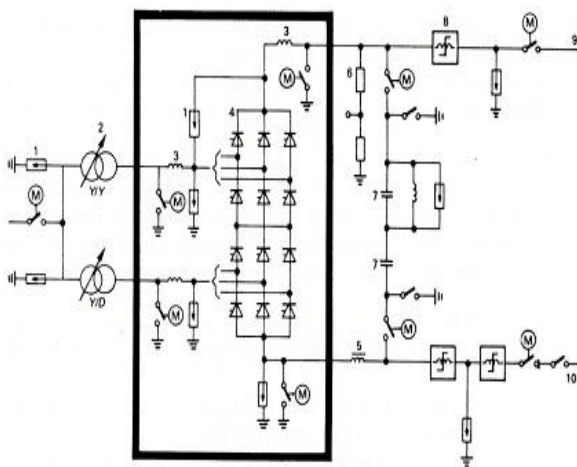

Fig2 The Main Circuit Diagram for One Pole of a Converter Station.

1. Surge Arrester
2. Converter Transformer
3. Air-Core Reactor
4. Thyristor Valve
5. Smoothing Reactor
6. Voltage Measuring Divider
7. DC Filter
8. Current Measuring Transducer
9. DC Line

10. Electrode Line

For a 12-pulse converter, the components are shown in Fig 4.1. In order to provide the 30° phase-shift for 12-pulse operation, the transformer valve-side windings must be connected in star-star and star-delta respectively. In order to limit any steep-front surges entering the station, a smoothing reactor is located on the DC side. The measuring equipments, such as voltage divider and current transducer, can provide the accuracy input signals for the control and protection systems. The switching components, such as isolators and circuit breakers, are used for the changeover from monopole metallic return to bipolar operation. Fig 4.2 indicates the relative space of the various components for a bipolar converter station. The areas of shunt capacitor banks and AC filter banks are the major proportion of the entire area and the valve hall and control room only take a small fraction of the total station area.

**III. RECTIFIER AND INVERTER CONTROLS**

The control model mainly consists of ( $\alpha/\gamma$ ) measurements and generation of firing signals for both the rectifier and inverter. The PLO is used to build the firing signals. The output signal of the PLO is a ramp, synchronized to the phase-A commutating.

Following are the controllers used in the control schemes:

- Extinction Angle ( $\gamma$ ) Controller
- DC Current Controller;
- Voltage Dependent Current Limiter (VDCOL).

**1) Rectifier Control:**

The rectifier control system uses Constant Current Control (CCC) technique. The reference for current limit is obtained from the inverter side. This is done to ensure the protection of the converter in situations when inverter side does not have sufficient dc voltage support (due to a fault) or does not have sufficient load requirement (load rejection) [6]. The reference current used in rectifier control depends on the dc voltage

available at the inverter side. Dc current on the rectifier side is measured using proper transducers and passed through necessary filters before they are compared to produce the error signal. The error signal is then passed through a PI controller, which produces the necessary firing angle order. The firing circuit uses this information to generate the equidistant pulses for the valves using the technique described earlier.

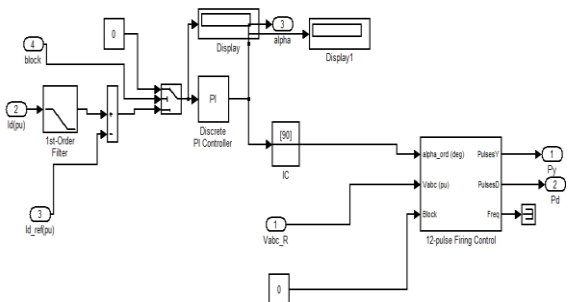

Fig 3. Rectifier control with PI.

## 2) Inverter Control:

The Extinction Angle Control or  $\gamma$  control and current control have been implemented on the inverter side. The CCC with Voltage Dependent Current Order Limiter (VDCOL) [7] have been used here through PI controllers. The reference limit for the current control is obtained through a comparison of the external reference (selected by the operator or load requirement) and VDCOL (implemented through lookup table) output. The measured current is then subtracted from the reference limit to produce an error signal that is sent to the PI controller to produce the required angle order. The  $\gamma$  control uses another PI controller [8] to produce gamma angle order for the inverter. The two angle orders are compared, and the minimum of the two is used to calculate the firing instant.

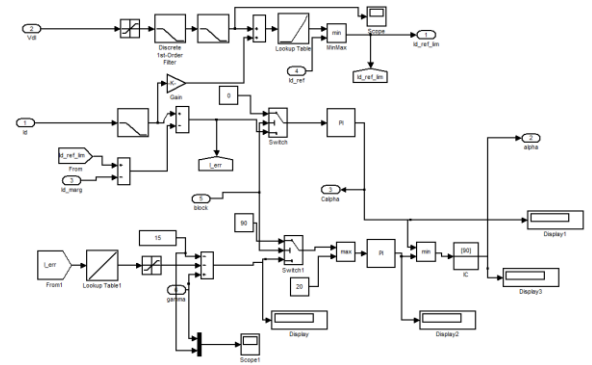

Fig 4. Inverter control with PI.

## IV. SIMULATION RESULTS AND DISCUSSION

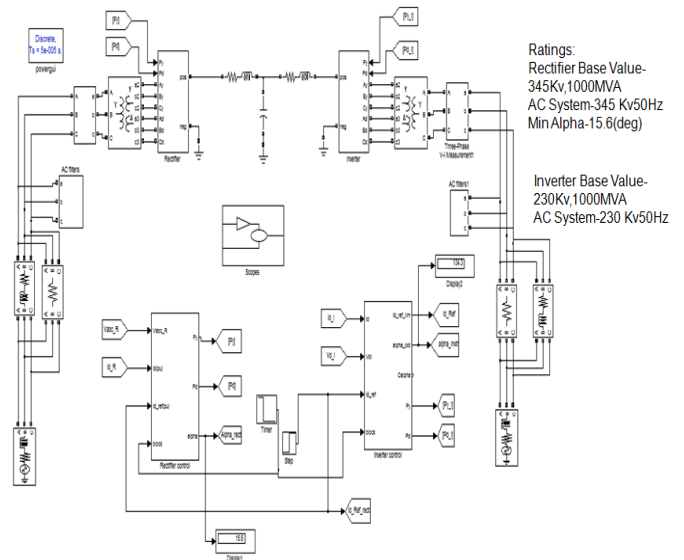

Fig 5. Simulink model of HVDC System

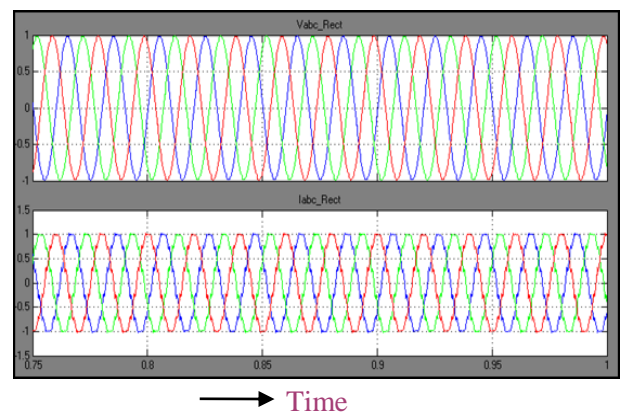

Fig 6. Rectifier side AC Voltage and AC Current

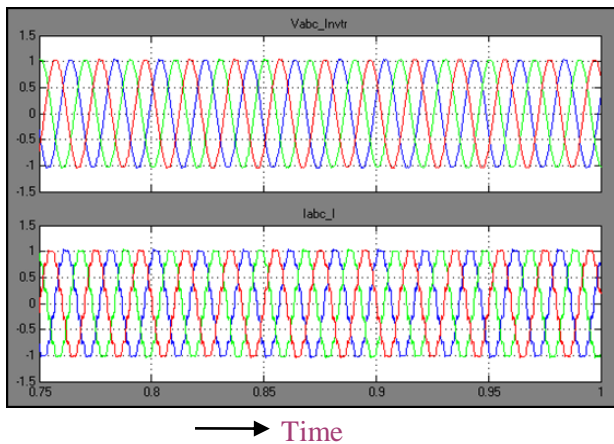

Fig 7. Inverter side AC Voltage and AC Current

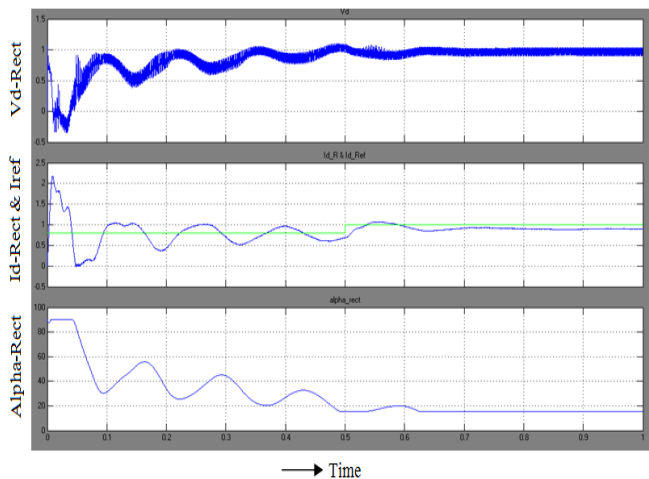

Fig 8. Rectifier side DC Voltage, DC Current and firing angle order with PI

From the above graph  $I_{d,R}$  and  $I_{d,Ref}$  are compared to produce an error signal which gives the firing angle order ( $\alpha=15.5$  deg).

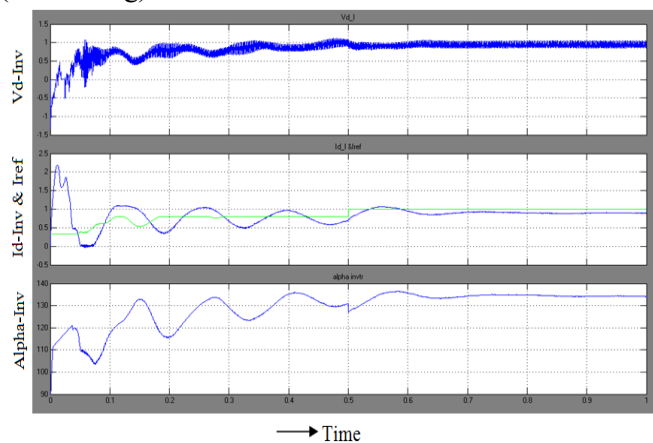

Fig 9. Inverter side DC Voltage, DC Current and firing angle order with PI

angle order with PI

From the above graph  $I_{d,I}$  and  $I_{d,Ref}$  are compared to produce an error signal which gives the firing angle order ( $\alpha_{inv}=134$  deg).

## V. DESIGN OF ARTIFICIAL NEURAL NETWORKS

The fundamental processing element of a neural network is neurons. This building block of human awareness encompasses a few general capabilities. Basically, biological neurons receive inputs from other sources, combine them in some way, perform a generally nonlinear operation on the result, and then output the final result. Figure 7.1 shows the relationship of these four parts. Within humans there are many variations on this basic type of neurons, further complicating man's attempts at electrically replicating the process of thinking. Yet, all natural neurons have the same four basic Components.

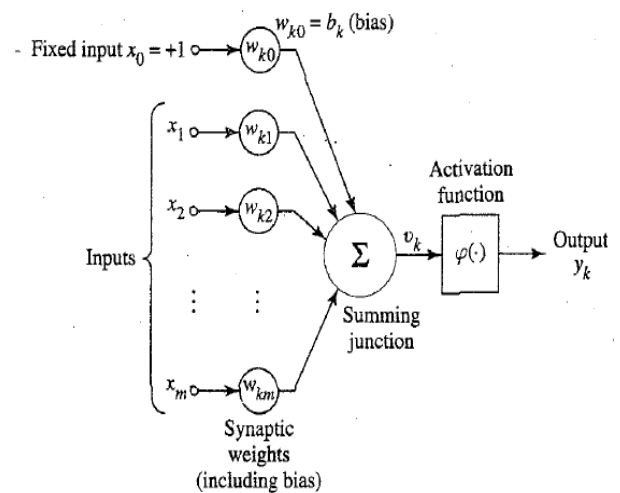

Fig10. Artificial Neural Networks

### Supervised Training

In supervised training, both the inputs and the outputs are provided. The network then processes the inputs and compares its resulting outputs against the desired outputs. Errors are then propagated back through the system, causing the system to adjust the weights are continually tweaked. The set of data which enables the

training is called the “training set”.

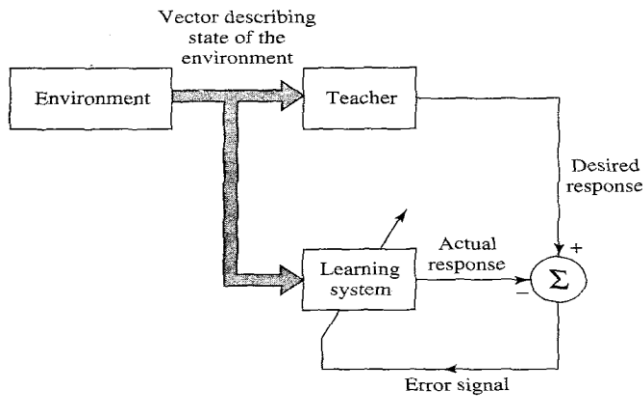

Fig11. Supervised training

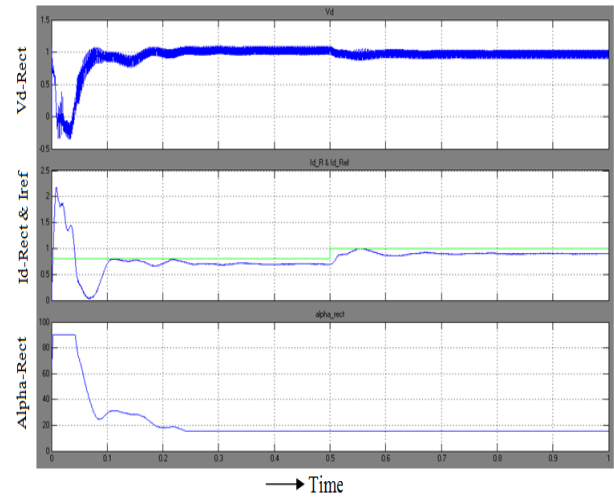

Fig 14. Rectifier side DC Voltage, DC Current and firing angle order with ANN

From the above graph  $I_{d_R}$  and  $I_{d\_Ref}$  are compared to produce an error signal which gives the firing angle order ( $\alpha=15.5$  deg).

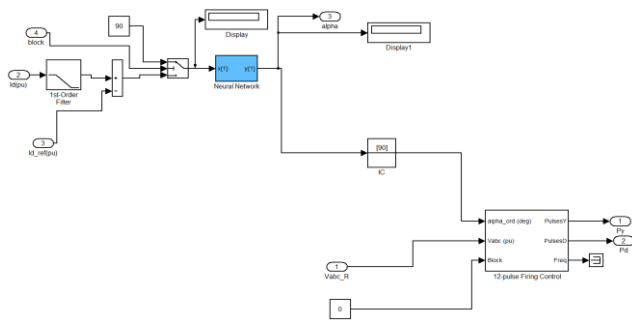

Fig 12. Rectifier control with ANN.

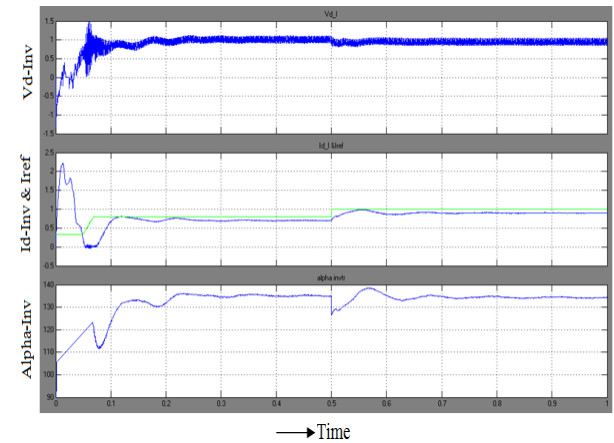

Fig 15. Inverter side DC Voltage, DC Current and firing angle order with ANN

From the above graph  $I_{d_I}$  and  $I_{d\_Ref}$  are compared to produce an error signal which gives the firing angle order ( $\alpha_{inv}=142$  deg).

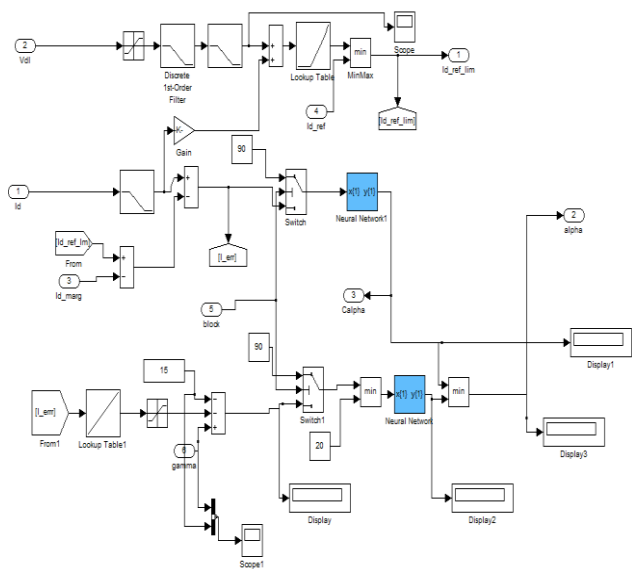

Fig 13. Inverter control with ANN

**TABLE I**  
**EFFECT DUE TO CHANGE IN RECTIFIER**  
**FIRING ANGLE USING ANN**

Rectifier $\alpha$ (degrees)	Inverter $\alpha$ (degrees)	$I_d_R$ (p.u)	$I_d_I$ (p.u)	$V_d_R$ (p.u)	$V_d_I$ (p.u)
15.5	142	0.903	0.9024	1.019	0.869
30	130	0.852	0.848	0.835	0.847
45	120.5	0.753	0.734	0.784	0.702
60	112	0.452	0.432	0.468	0.452
75	101	0.301	0.312	0.321	0.312

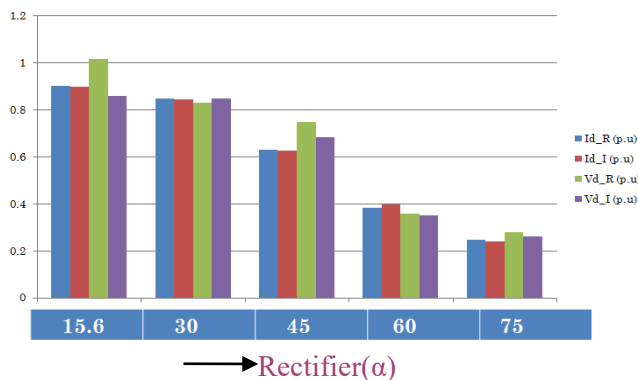

Fig 16. Effect due to change in Rectifier firing angle (chart representation) using ANN

### V1. Conclusion

In this paper, a HVDC system is designed to control the power flow between two converter stations with conventional controller and Artificial neural networks. The simulation results shows that the HVDC system with Artificial neural networks have better power flow control when compared with PI controller for different firing angles.

### APPENDIX I HVDC System Data

Parameters	Rectifier	Inverter
AC Voltage Base	345 kV	230 kV
Base MVA	1000 MVA	1000 MVA
Transformer taps (HV side)	1.01 p.u.	0.989 p.u.
Nominal DC Voltage	500 kV	500 kV
Nominal DC Current	2 kA	2 kA
Transformer $X_l$	0.18 p.u.	0.18 p.u.
Source Impedance	$R=0.4158\Omega, L=0.0206H$	$R=0.7406\Omega, L=0.0365H$
System Frequency	50 Hz	50 Hz
Nominal Angle	$\alpha=15^\circ$	$\gamma=15^\circ$

### References

- [1] M. O. Faruque, Yuyan Zhang and V. Dinavahi, "Detailed modeling of CIGRE HVDC benchmark system using PSCAD/EMTDC and PSB/SIMULINK," IEEE Trans. Power Delivery, vol.21, no.1, pp. 378 –387, Jan. 2006.
- [2] Das, B.P.; Watson, N.; Yonghe Liu; , "Simulation study of conventional and hybrid HVDC rectifier based on CIGRÉ benchmark model using PLL-less synchronisation scheme," Power Engineering and Optimization Conference (PEOCO), 2011 5th International , vol., no., pp.312-317, 6-7 June 2011doi: 10.1109/PEOCO.2011.5970433.
- [3] Ashfaq Thahir, M.; Kirthiga, M.V.; , "Investigations on modern self-defined controller for hybrid HVDC systems," TENCON 2011 - 2011 IEEE Region 10 Conference , vol., no., pp.938-943, 21-24 Nov. 2011doi: 10.1109/TENCON.2011.6129248.
- [4] Das, B.P.; Watson, N.; Yonghe Liu; , "Comparative study between gate firing units for CIGRE benchmark HVDC rectifier," Industrial Electronics and Applications (ICIEA), 2011 6th IEEE Conference on , vol.,no.,pp.299-306,21-23June2011 doi:



10.1109/ICIEA.2011.5975598.

[5] Sood, V.K.; Khatri, V.; Jin, H.; , "EMTP modelling of CIGRE benchmark based HVDC transmission system operating with weak AC systems," Power Electronics, Drives and Energy Systems for Industrial Growth, 1996., Proceedings of the 1996 International Conference on , vol.1, no., pp.426-432 vol.1, 8-11 Jan 1996doi: 10.1109/PEDES.1996.539653.

[6] Kala Meah, A.H.M. Sadrul Ula, "Simulation Study of the Frontier Line as a Multi-Terminal HVDC System," IEEE PES General Meeting, July 20- 24, 2008, Pittsburg, PA, USA.

[7] N.G. Hingorani, "Power Electronics in Electronic Utilities: Role of Power Electronics in Future Power Systems," Proceeding of the IEEE, Vol. 76, No. 4, April, 1988, pp. 481-482.

[8] A. Ekstrom and G. Liss, "A Refined HVDC Control System," IEEE Transactions on Power Apparatus and Systems, Vol. PAS-89, No. 5, May/June 1970, pp. 723-732.