

Fuzzy Controlled Shunt Active Filter for Harmonic Reduction

V. Anil Kumar

Department of Electrical and
Electronics Engineering,
ANITS, Visakhapatnam,
Andhra Pradesh 531162, India.

L Vijay

Department of Electrical and
Electronics Engineering,
ANITS, Visakhapatnam,
Andhra Pradesh 531162, India.

S.J.V Prakesh

Department of Electrical and
Electronics Engineering,
ANITS, Visakhapatnam,
Andhra Pradesh 531162, India.

ABSTRACT:

This paper proposes a new control method of three phase active power filter for reducing the source current harmonics for nonlinear loads. The control strategy includes the dq transformations and hysteresis technique for current injection. Renewable energy source (solar energy) is used as a backup device for converter. Dc voltage deviations due to harmonic injections are tracked by using proportional + integral control and fuzzy logic controller. The proposed work is implemented on MATLAB simulation software.

Key Words: Active power filters, dc capacitor voltage fluctuations, harmonic detection, load change.

I. INTRODUCTION:

Active power filters (APFs) have been developed and put into practical use for reducing the harmonic current produced by harmonic-producing loads in power systems [1], [2]. An APF reduces the source harmonic current by absorbing harmonic current which is anti-phase from the harmonic currents drawn by the harmonic-producing load. The APF requests a high-accuracy and a small-phase delay in the harmonic-detection and the current-control circuit and/or method to improve the compensation performance [3], [4]. Various control methods have been proposed mainly to improve harmonic compensation characteristics [5]. Nakata et al. [6] have proposed the application of moving average filters to a comprehensive harmonic detection method for reducing the steady-state error. The current control performance of the APF is also an important factor for the improvement of harmonic compensation characteristics. A deadbeat control method and a quadruple sampling technique for single-phase APFs

have been reported to expand the current control bandwidth. Any control method causes an amount of instantaneous active power flowing into/out of APFs, which is formed by the source voltage and the compensating current.

Akagi et al. have reported that compensating only instantaneous reactive power causes no dc-capacitor voltage fluctuations. However, harmonic compensation performance decreases. On the other hand, dc-capacitor voltage control methods have also been discussed to improve the control stability and to reduce the voltage fluctuations. A control method using the Lyapunov function has been proposed to improve the stability of the feedback control of the dc-capacitor voltage against the quick reference change.

The authors have proposed a harmonic detection method for a single-phase APF, which can greatly reduce the capacitance value. The harmonic detection method can control the energy flowing into the dc capacitor to be zero for one source cycle after the sudden load change. However, the harmonic detection method is not enough to decrease the voltage fluctuations in a three-phase APF because the transient voltage fluctuations is much greater than the voltage ripple in steady states. This paper proposes a new control method capable of reducing the capacitance value of the dc capacitor for three-phase APFs.

The proposed method employs a newly-developed k-step

Cite this article as: V. Anil Kumar, L Vijay & S.J.V Prakesh, "Fuzzy Controlled Shunt Active Filter for Harmonic Reduction", International Journal & Magazine of Engineering, Technology, Management and Research, Volume 6 Issue 3, 2019, Page 39-46.

compensator to reduce undesired energy flowing into or out of the dc capacitor. As a result, the proposed method makes it possible to restrain the voltage fluctuations across the dc capacitor even when a sudden load change occurs. Thus, the APF using the proposed method can continuously operate without overvoltage in transient states even when a small dc capacitor is employed. This paper theoretically analyzes characteristics of the newly developed k-step compensator paying attention to the reducing performance of the voltage fluctuations. In this paper, the harmonic detection method is referred to a two-step compensator.

Since the rapid development of the semiconductor industry, power electronics devices have gained popularity in our daily used electrical house-hold appliances. Although these power electronics devices have benefited the electrical and electronics industry, these devices are also the main source of power harmonics in the power system. These power harmonics are called electrical pollution which will degrade the quality of the power supply. As a result, filtering process for these harmonics is needed in order to improve the quality of the power supply. Thus, active power filter seems to be a viable alternative for power conditioning to control the harmonics level in the power system nowadays. Power system normally operates at 50 or 60 Hz. However, saturated devices such as transformers, arching loads such as florescent lamp and power electronic devices will produce current and voltage components with higher frequencies into the power line. These higher frequencies of current and voltage components are known as the power harmonics. The harmonics disturbances in the power supply are caused by the nonlinearity characteristic of the loads. Due to the advantages in efficiency and controllability of power electronic devices, their applications can be found in almost all power levels.

II. CONTROL OF HARMONICS:

Passive filters:

Traditional solutions for these problems are power-factor-correction (PFC) techniques, passive filters due to

their easy design, simple structure, low cost and high efficiency. These usually consist of a bank of tuned LCfilters to suppress current harmonics generated by nonlinear loads. Passive filters have many disadvantages, such as Resonance, Large size, fixed compensation character, possible overload, With the PFC approach, a PFC unit is usually in cascade in the energy pass, which processes all the power and corrects the current to unity power factor. Those kinds of approaches are usually suitable for low-power (less than 5kVA) applications

Active filters:

To overcome the disadvantages due to Passive Filters, Active Power Filters (APFs) have been presented as a current-harmonic compensator for reducing the total harmonic distortion of the current and correcting the power factor of the input source. The Active Power Filter is connected in parallel with a nonlinear load. The approach is based on the principle of injecting harmonic current into the ac system, of the same amplitude and reverse phase to that of the load current harmonics.. This will thus result in sinusoidal line currents and unity power factor in the input power system. In this case, only a small portion of the energy is processed, which may result in overall higher energy efficiency and higher power processing capability. These kinds of approaches are applicable for low-power (less than 5kVA) to high-power applications (around 100kVA).

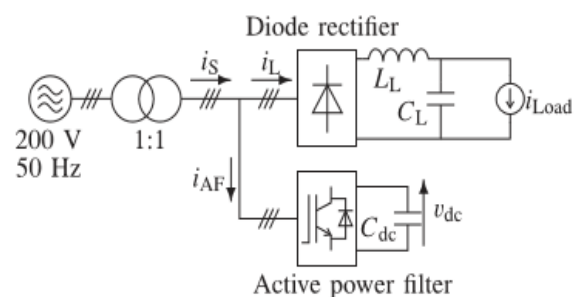

Figure 1: Block diagram of proposed APF

A three-phase shunt APF is typically composed of a three-phase bridge converter and control circuitry. Most of the previous control approaches need to sense the load

current and calculate its harmonics and reactive components in order to generate the reference for controlling the current of a bridge converter. Those control methods require fast and real-time calculation; therefore, a high-speed digital microprocessor and high-performance A/D converters are necessary, which yields high cost, complexity, and low stability.

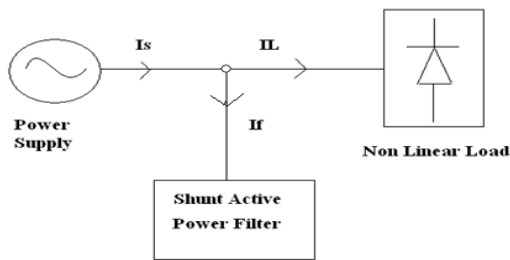

Figure 2: Basic principle of harmonic currents compensations

The harmonic current compensations by the active power filter are controlled in a closed loop manner. The active power filter will draw and inject the compensating current, I_f to the line based on the changes of the load in the power supply system. The supply line current, I_s is described by the following equation,

$$I_s = I_f + I_L$$

The line current, I_s is shaped to be sinusoidal by adding the compensating current, I_f into the distorted load current, I_L .

III. CONTROL SCHEME OF ACTIVE POWER FILTERS:

The main aim of an active power filter (APF) is to generate compensating currents into the power system for canceling the current harmonics contained in the nonlinear load current. This will thus result in sinusoidal line currents and unity power factor in the input power system. The exclusive features of this proposed PWM controlled APF are concluded as follows:

- (a) The reference frame transformation and a digital low pass filter are used to compute the harmonics of the nonlinear load current.
- (b) The voltage decouplers and pole-zero cancellation method are used in the current controllers of the active

power filter to provide fast current harmonic compensation and simplify the control scheme.

(c) The delay times of both current response of an active power filter and DC-link voltage feedback are considered. This results in decreasing the settling time of the DC-link voltage and reducing the high frequency current harmonic components of the power system.

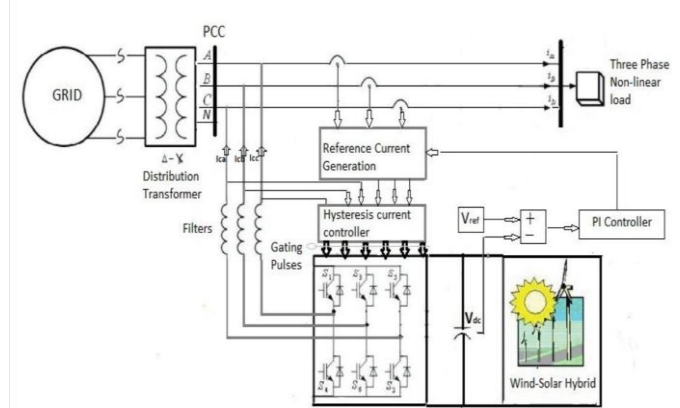

Figure 3: control block diagram of hysteresis controlled APF

e_a, e_b, e_c And v_{af}, v_{bf}, v_{cf} represent the phase voltages of a power system and the input voltages of a power converter, i_{af}, i_{bf}, i_{cf} and v_{dc2} denote the input currents of the active power filter and the DC-link voltage, respectively. Neglecting the reactors L_s of the input power system, the differential equations of the three-phase active Power filter can be described as follows.

$$L_2 \frac{d}{dt} i_{af} = e_a - R_2 i_{af} - v_{af}$$

$$L_2 \frac{d}{dt} i_{bf} = e_b - R_2 i_{bf} - v_{bf}$$

$$L_2 \frac{d}{dt} i_{cf} = e_c - R_2 i_{cf} - v_{cf}$$

$$C_2 \frac{d}{dt} v_{dc2} = f_a i_{af} + f_b i_{bf} + f_c i_{cf}$$

Where C_2 is the capacitance of the DC-link capacitor, R_2 and L_2 are the resistance and inductance of the active power filter line reactors, respectively, f_a, f_b, f_c are Switching functions, and the possible values are

$0, \pm \frac{1}{3}$ and $\pm \frac{2}{3}$. For model analysis and controller design, the three-phase voltages, currents and switching functions can be transformed to a $d-q-o$ rotating frame. This yields,

$$\begin{bmatrix} X_d \\ X_q \\ X_o \end{bmatrix} = \frac{2}{3} \begin{bmatrix} \sin \theta_e & \sin \left(\theta_e - \frac{2\pi}{3} \right) & \sin \left(\theta_e + \frac{2\pi}{3} \right) \\ \cos \theta_e & \cos \left(\theta_e - \frac{2\pi}{3} \right) & \cos \left(\theta_e + \frac{2\pi}{3} \right) \\ \frac{1}{2} & \frac{1}{2} & \frac{1}{2} \end{bmatrix} \begin{bmatrix} X_a \\ X_b \\ X_c \end{bmatrix}$$

Finally

$$L_2 \frac{d}{dt} i_{df} = e_d - R_2 i_{df} + \omega_e L_2 i_{qf} - v_{df}$$

$$L_2 \frac{d}{dt} i_{qf} = e_q - R_2 i_{qf} - \omega_e L_2 i_{df} - v_{qf}$$

$$C_2 \frac{d}{dt} v_{dc2} = \frac{3}{2} (f_d i_{df} + f_q i_{qf})$$

where

$$v_{df} = f_d v_{dc2}$$

$$v_{qf} = f_q v_{dc2}$$

ω_e is the frequency of the power system and the subscripts 'd' and 'q' are used to denote the components of the d - and q -axis in the rotating frame, respectively. Equations will be used to derive the block diagram of the active power filter and calculate the input voltage commands of power converter.

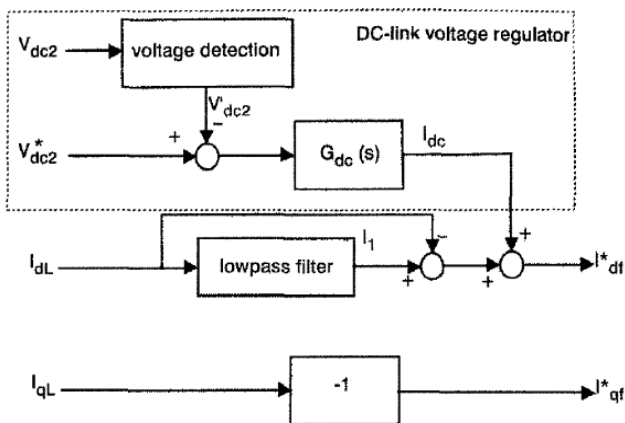

Figure 4: Block diagram of d- and q-axis reference current of active power filter

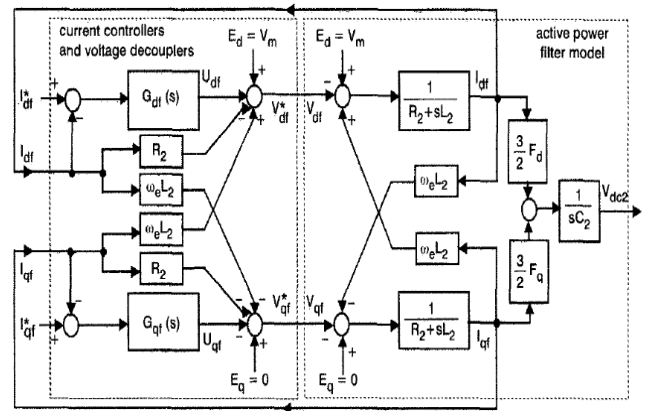

Figure 5: Control block diagram of d- and q-axis current controllers of active power filter.

IV TEST SYSTEM MODEL:

In the existing literature, the analytical model of an active power filter is complicated and is difficult for the design of current regulators and DC-link voltage regulators. To improve these disadvantages, a current controller with voltage decoupler is presented here to simplify the analytical model. This Section first discusses the time-delay concepts including reference current delay, current response delay and the DC-link voltage feedback delay. Considering these delay times, the analytical model and closed-loop transfer functions for the active power filter are then derived. Finally, the boundary conditions between the stable and unstable operations for the active power filter system are discussed in detail.

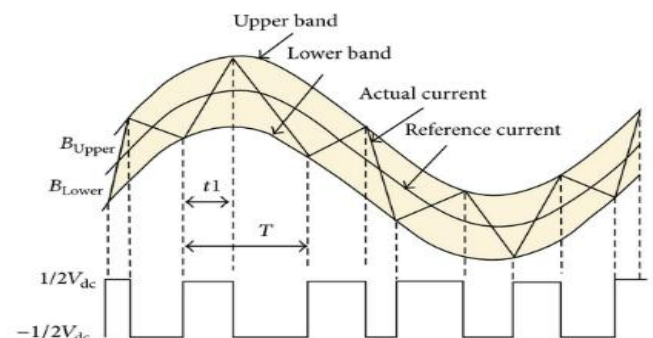

Figure 6: hysteresis current controller

Hysteresis current controller is used for pulse generation by using band width relay technology.

The block diagram of a DC-link voltage regulator is shown in Figure. The proportional-integral controller $G_{dc}(s)$ for the DC-link voltage control loop in equation.(3.18) has the Characteristic

$$G_{dc}(s) = \left(K_{P\ dc} + \frac{K_{I\ dc}}{s} \right)$$

The turn on and turn off instants of inverter switches should be such that the load and the connected RES could appear as balanced load to the system. The dc link voltage, V_{dc} is sensed at a regular interval and is compared with its reference counterpart V_{dc}^* . The error signal is processed in a PI-controller. The output of the pi controller is denoted as I_m

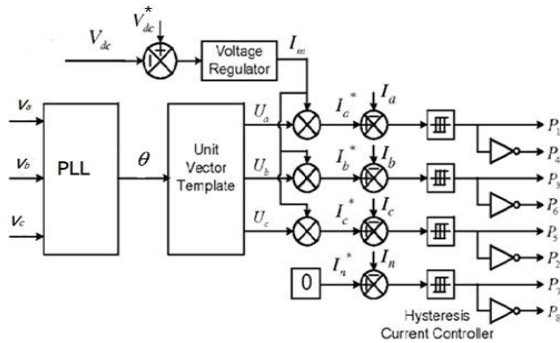

Figure 7: control scheme of the model

Total system is shown as five sub systems; those are Three-phase ac source, which is supplying for Non-linear load. Active Power Filter (APF), that is connected parallel to the load and also PWM controller subsystem which is giving pulses to the APF such that it will inject compensation currents into the power line which are opposite in phase to the harmonic currents introduced by the nonlinear loads. Total controller subsystem will provide reference voltages to the PWM controller subsystem. Here the reference voltages are compared with the triangular wave which is having frequency of 10KHZ and produced the switching gate pulses for the power converter.

PHOTOVOLTAIC CELL

A device that produces an electric reaction to light produces electricity. PVcells do not use the sun's heat to produce electricity. They produce electricity directly

when sunlight interacts with semiconductor materials in the PVcells.

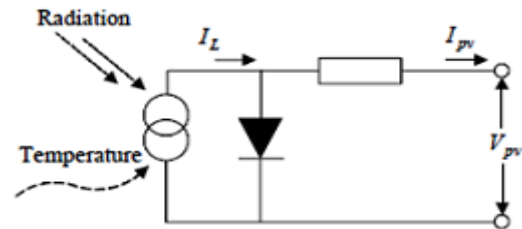

Photovoltaic cell equivalent circuit

Fuzzy Logic Controllers:

Introduction to Fuzzy Logic: The logic of an approximate reasoning continues to grow in importance, as it provides an inexpensive solution for controlling know complex systems. Fuzzy logic controllers are already used in appliances washing machine, refrigerator, vacuum cleaner etc. Computer subsystems (disk drive controller, power management) consumer electronics (video, camera, battery charger) C.D. Player etc. and so on in last decade, fuzzy controllers have convert adequate attention in motion control systems. As the later possess non-linear characteristics and a precise model is most often unknown. Remote controllers are increasingly being used to control a system from a distant place due to inaccessibility of the System or for comfort reasons. In this work a fuzzy remote controllers is developed for speed control of a converter fed dc motor. The performance of the fuzzy controller is compared with conventional P-I controller.

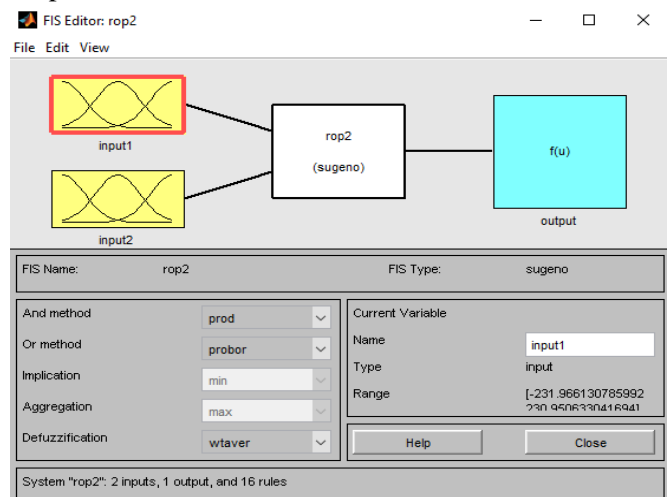

Figure 8: Fuzzy inference system

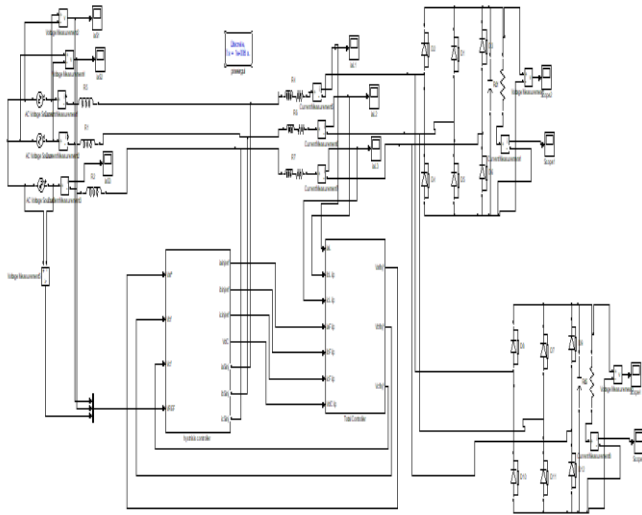

Figure 9: Simulink Model of hysteresis Controlled APF for the Three-Phase Power System

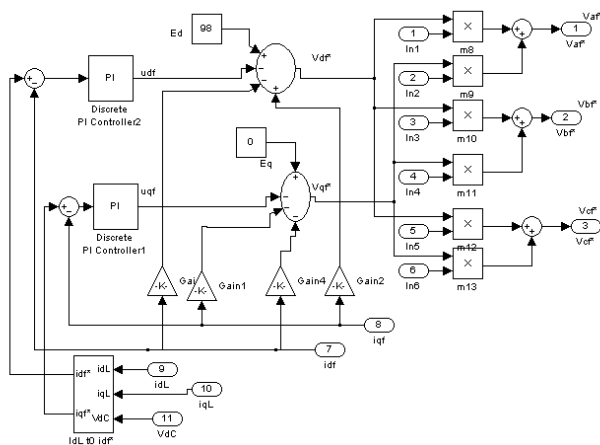

Figure 10: Simulink Model for d and q axis current controllers of APF

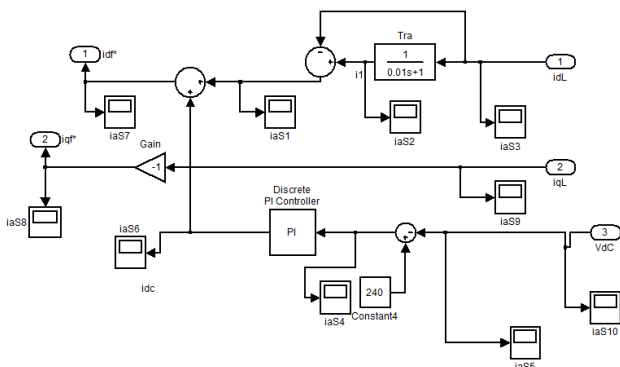

Figure 11: Simulink Model of PI controller based APF

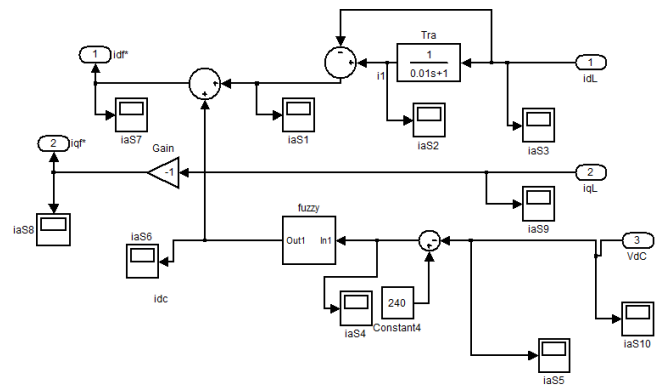

Figure 12: Simulink Model of fuzzy controller based APF

V. RESULTS:

The obtained results of test system are

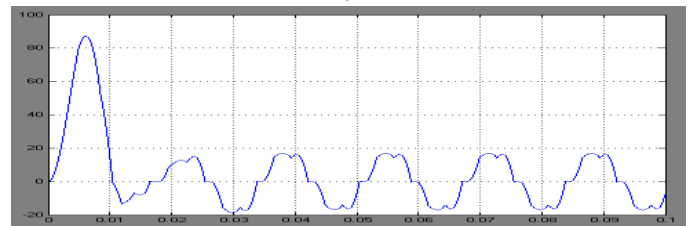

Figure 13: Source current without filter

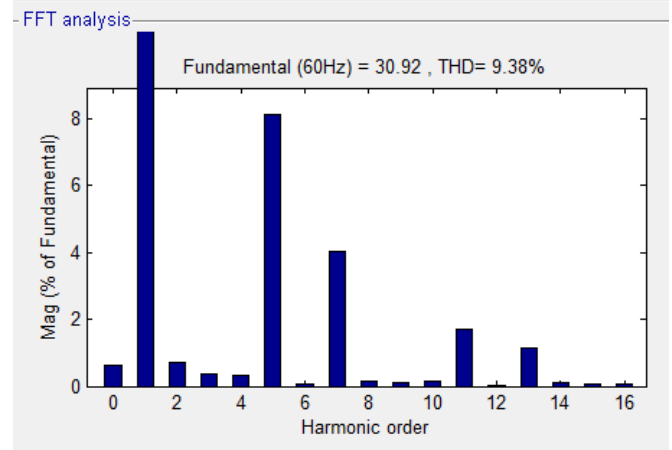
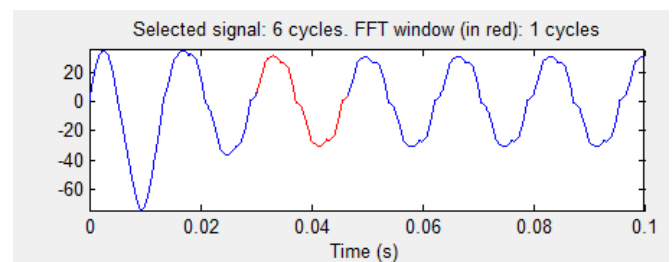

Figure 14: THD without active filter

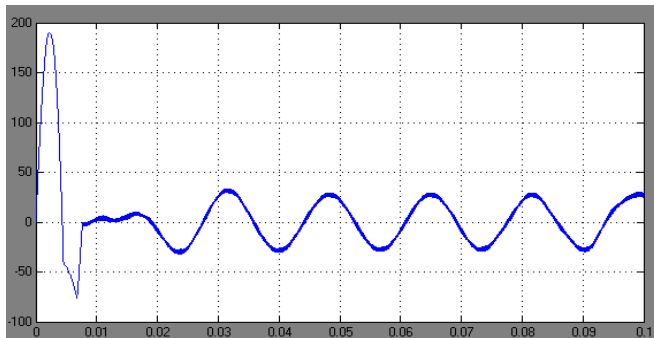

Figure 13: Single phase source current with hysteresis technique using PI controller



Figure 15: Converter DC voltage under operating condition using PWM

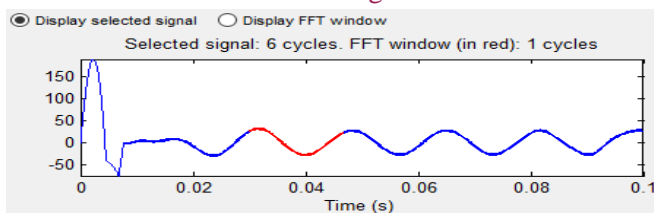

Figure 16: THD with PI Controller

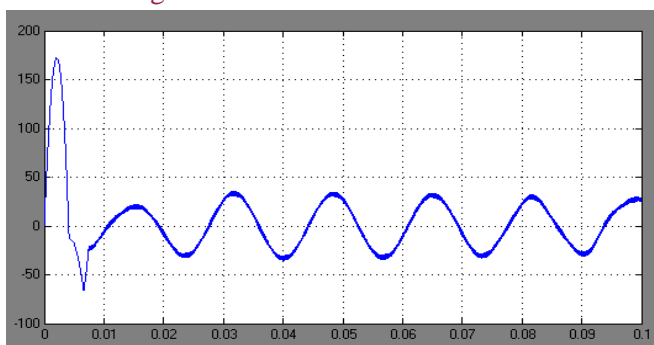

Figure 17: Source current with fuzzy controller

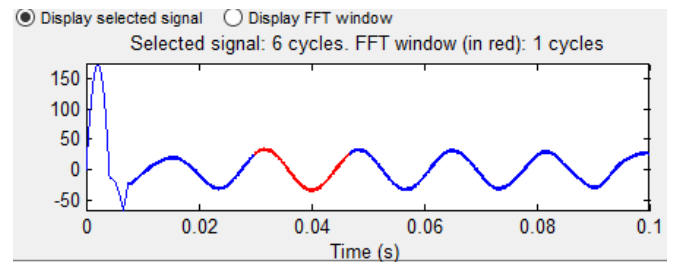

Figure 18: THD of source current using fuzzy controller

VI. CONCLUSION:

This project has proposed a new harmonic current detection method which can reduce the current harmonics and voltage fluctuations caused by nonlinear loads. The controller input signals are from dc bus voltage and load currents with changes when there are any external disturbances. by using general PI technique to the proposed detection technique the total harmonics distortion reduced to 6.13% from 9.38%. And if the pulse generation technique is replaced by using FUZZY control the THD is reduced to 3.99% from the above results we can conclude that by using fuzzy based hysteresis current control technique we get better results.

VII. REFERENCES:

- [1] S. Bhattacharya, T. M. Frank, D. M. Divan, and B. Banerjee, "Active filter system implementation," IEEE Ind. Appl. Mag., vol. 4, no. 5, pp. 47–63, Sep./Oct. 1998.
- [2] B. Singh, K. Al-Haddad, and A. Chandra, "A review of active filters for power quality improvement," IEEE Trans. Ind. Electron., vol. 46, no. 5, pp. 960–971, Oct. 1999.

- [3] L. Asiminoael, F. Blaabjerg, and S. Hansen, "Detection iskey—Harmonic detection methods for active power filter applications," *IEEE Ind. Appl. Mag.*, vol. 13, no. 4, pp. 22–33, Jul./Aug. 2007. *Trans. Ind. Electron.*, vol. 53, no. 2, pp. 477–485, Apr. 2006
- [4] A. Bhattacharya, C. Chakraborty, and S. Bhattacharya, "Shunt compensation," *IEEE Ind. Electron. Mag.*, vol. 3, no. 3, pp. 38–49, Sep. 2009.
- [5] T. Ohnishi and H. Yamauchi, "Active filter by instantaneous ripple line power reduction," *IEEE Trans. Ind. Appl.*, vol. 111, no. 11, pp. 921–929, 1991.
- [6] A. Nakata, A. Ueda, and A. Torii, "A method of current detection for an active power filter applying moving average to pq-theory," in *Proc. 29th Annu. IEEE Power Electron. Specialists Conf.*, 1998, vol. 1, pp. 242–247.
- [7] P. Jintakosonwit, H. Fujita, and H. Akagi, "Control and performance of a fully-digital-controlled shunt active filter for installation on a power distribution system," *IEEE Trans. Power Electron.*, vol. 17, no. 1, pp. 132–140, Jan. 2002.
- [8] W. Merk, H. Stemmler, and J. Allmeling, "Stationary-frame generalized integrators for current control of active power filters with zero steady-state error for current harmonics of concern under unbalanced and distorted operating conditions," *IEEE Trans. Ind. Appl.*, vol. 38, no. 2, pp. 523–532, Mar./Apr. 2002.
- [9] P. Jintakosonwit, H. Akagi, H. Fujita, and S. Ogasawara, "Implementation and performance of automatic gain adjustment in a shunt-active filter for harmonic damping throughout a power distribution system," *IEEE Trans. Power Electron.*, vol. 17, no. 3, pp. 438–447, May 2002.
- [10] M. E. Ortuzar, R. E. Carmi, J. W. Dixon, and L. Moran, "Voltage-source active power filter based on multilevel converter and ultra-capacitor DC link," *IEEE*