

## Design of Hybrid Active Filter for Power Quality Improvement of Electrical Distribution System Using Fuzzy Logic Controller

M. Ajay

Department of Electronics and Electrical Engineering,  
Avanthi institute of Engineering and Technology  
Visakhapatnam, Andhra Pradesh - 535006, India.

G. Prasanth

Department of Electronics and Electrical Engineering,  
Avanthi institute of Engineering and Technology  
Visakhapatnam, Andhra Pradesh - 535006, India.

### Abstract:

Rapid growth of non-linear loads in distribution systems has attracted power system engineers' attention from power quality point of view. Connection of the non-linear loads deteriorates power quality in the distribution system by introducing current harmonics. These current harmonics, when circulated in the electric network, interact with the system impedance and generate voltage harmonics. These current and voltage harmonics together can affect other consumers connected in the distribution network. Some typical non-linear loads, such as electric arc furnace (EAF), are inherent source of voltage harmonics which gives rise to voltage flicker, which can causes large voltage fluctuation in the connected distribution system.

This paper presents performance evaluation of hybrid active filter (HAF) for power quality improvement (EAF) connected distribution system. The performance of HAF is evaluated in terms of harmonic and voltage flicker mitigation capability. The HAF is consisting of a shunt passive filter (PF) connected with a lower rated voltage source PWM converter based series active filter (SAF). There are various control strategies for series active filter control is surveyed in the literature. One of the control strategy based on the dual formulation of the electric power vectorial theory is implemented for balance and resistive load. In this paper an attempt is made to apply the same control theory for unbalanced and non-sinusoidal voltage conditions of the distribution system. Simulation for a typical distribution system along with the PF and the SAF has been carried out in MATLAB environment to validate the performance.

Fuzzy logic controller is used to increase the percentage of power quality improvement in terms of voltage sag.

### Keywords:

Active power filter (APF), distributed generation (DG), distribution system, grid interconnection, power quality (PQ), renewable energy.

### I. INTRODUCTION:

Fossil fuels are our main source of energy and they are depleting. Fossil fuels are non renewable and environmentally damaging. Due to increasing air pollution, global warming concerns, diminishing fossil fuels and their increasing cost have made it necessary to look towards renewable sources as a future energy solution. There are many Renewable Energy Sources (RES) such as wind, solar, tidal power, biomass etc. Solar energy has great potential to supply energy with minimum impact on the environment, since it is clean and pollution free. In finding solutions to overcome a global energy crisis, the Photo Voltaic (PV) system has attracted significant attention in recent years. The government is providing incentives for further increasing the use of grid-connected PV systems. Conventionally, grid connected Photo Voltaic energy conversion systems are composed of an inverter. Renewable Energy Sources are increasingly integrated at the distribution level due to increase in load demand which utilize power electronic converters.

Cite this article as: M. Ajay & G. Prasanth, "Design of Hybrid Active Filter for Power Quality Improvement of Electrical Distribution System Using Fuzzy Logic Controller", International Journal & Magazine of Engineering, Technology, Management and Research, Volume 5, Issue 5, 2018, Page 13-19.

There is a disturbance in the electrical network due to the extensive use of these power electronic devices. The disturbances are due to the use of non-linear devices. These will introduce harmonics in the power system thereby causing equipment overheating, damage devices, EMI related problems etc [1],[2]. Harmonics is considered as one of the most essential problems in electrical power systems. Harmonics in power distribution system are current or voltage that are integer multiples of fundamental frequency. For example if the fundamental frequency 50Hz, then 3rd is 150Hz, 5th is 250Hz. Ideally, voltage and current waveforms are perfect sinusoids. However, because of the increased popularity of electronic and non linear loads, these waveforms become distorted.

This deviation from a perfect sine wave can be represented by harmonic components having a frequency that is an integral multiple of the fundamental frequency. Thus a pure voltage or current sine wave has no distortion and no harmonics and a non sinusoidal wave has distortion and harmonics. Several methods are described in various papers to solve these problems. There are standards that determine the maximum allowable level for each harmonic in the Alternative Current (AC) system [IEEE Std. 519, 1981]. When excessive harmonic voltage and current are generated, filters are usually installed to reduce the harmonic distortion.

There are two functions to connect harmonic filter to the lines in distribution systems as listed below.

1. To reduce the harmonic voltage and current in the AC system below the permitted levels.
2. To provide some of the reactive power absorbed by the converter system. [IEEE Std. 519, 1981]

Conventionally, passive filters have been used to eliminate harmonic problems [3]. This filter mainly consists of common devices such as inductance and capacitance. These devices are tuned to the frequency of the harmonic to be removed.

However it has the following limitations

1. A separate filter is necessary for each harmonic frequency.
2. As both the harmonic current and the fundamental frequency current flow into the filter, the capacity of the filter must be decided by taking into account both currents.
3. The filter will be overloaded when the content of the harmonic in the AC line increases.

Other methods of harmonic reduction are considered such as current injected by Active Power Filter (APF) to overcome the above limitations. The APF filter concept uses power electronic switching to generate harmonic components to cancel the harmonic components of the nonlinear loads. It means that in these devices, Direct Current (DC) is converted to form the harmonic currents out of phase of the load which is then injected into AC line, thereby preventing the harmonic currents flowing into the supply. The suitable device in developing the APF is utilizing Pulse Width Modulation (PWM) inverter by using power semiconductor devices such as Insulated Gate Bipolar Transistor (IGBT) or Metal Oxide Field Effect Transistor (MOSFET) [4]. The PWM is used because it can be easily adjusted in order to control amplitude harmonic current injection and frequency switching. Following are the reasons APF had been used to minimize harmonic pollution in the distribution line system compared with passive filter.

1. All the harmonics presented in AC line system can be compensated by using single equipment.
2. The maximum order of harmonic to be suppressed has no limitation and is determined by PWM switching
3. Even the existing harmonic components change in magnitude and frequency in line it can be accommodated by control adjustment by triangular and voltage reference circuit rather than equipment changes from time to time.
4. It is not designed to filter out one harmonic component only, but is intended to attenuate several harmonics in one time.

Compared with passive filter methods, the harmonic current injection into the power network by applied a high frequency switching inverter able to offers suppress harmonic as much as possible adequate with low cost. In this work, that the existing PV inverter acts as Shunt Active Power Filter (SAPF) that is capable of simultaneously compensating problems like current unbalance current harmonics and also of injecting the energy generated by RES. Shunt Active Power Filter attempts to compensate the current harmonics [5]. The shunt active filter is a voltage source inverter (VSI), which is connected in parallel with load. Shunt Active Power Filter has the ability to keep the mains current balanced and sinusoidal after compensation for various Load conditions.

**II. RENEWABLE BASED DISTRIBUTED GENERATION SYSTEM**

The proposed system is Three Phase Four wire which consists of Photovoltaic system connected to the dc-link of a grid-interfacing inverter as shown in Fig.4.1. The voltage source inverter is a key element of a PV system as it interfaces the renewable energy source to the grid and delivers the generated power. The Photovoltaic system is connected to grid with an inverter coupled to dc-link. The dc-capacitor decouples the Photovoltaic system from grid and also allows independent control of converters on either side of dc-link [6].

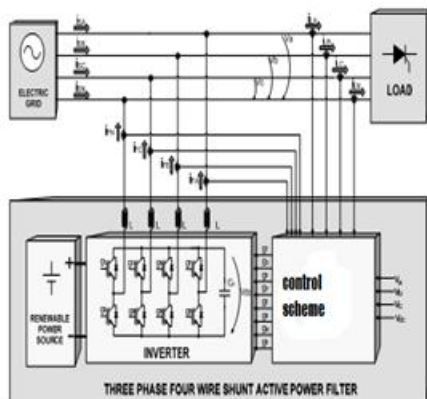
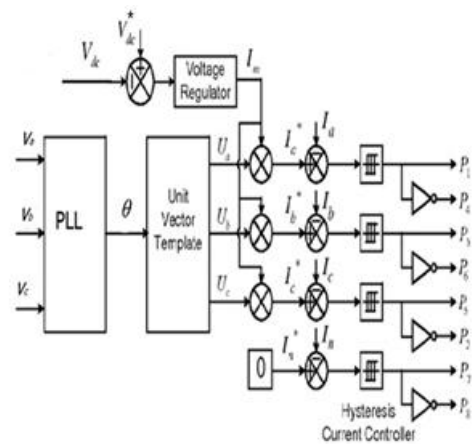

**Fig .1: Proposed Three Phase Four Wire System**

**2.1 VOLTAGE SOURCE CONVERTER (VSC):**

A voltage-source converter is a power electronic device that connected in shunt or parallel to the system. It can generate a sinusoidal voltage with any required magnitude, frequency and phase angle. It also converts the DC voltage across storage devices into a set of three phase AC output voltages. It is also capable to generate or absorbs reactive power. If the output voltage of the VSC is greater than AC bus terminal voltages, is said to be in capacitive mode. So, it will compensate the reactive power through AC system. The type of power switch used is an IGBT in anti-parallel with a diode [7]. The three phase four leg VSI is modeled in Simulink by using IGBT. Voltage source converters are preferred over current source converter because it is higher in efficiency and lower initial cost than the current source converters. They can be readily expanded in parallel to increase their combined rating and their switching rate can be increased if they are carefully controlled so that their individual switching times do not coincide. Therefore, higher-order harmonics can be eliminated by using converters without increasing individual converter switching rates [8].

**2.2 CONTROL TECHNIQUE USED FOR INTERFACING INVERTER TO ACT AS SHUNT APF**



**Fig 2:Control scheme**

The turn on and turn off instants of inverter switches should be such that the load and the connected RES could appear as balanced load to the system. The dc link voltage,  $V_{dc}$  is sensed at a regular interval and is compared with its reference counterpart  $V_{dc}^*$ . The error signal is processed in a PI-controller. The output of the pi controller is denoted as  $I_m$ . The reference current templates ( $I_a^*$ ,  $I_b^*$ , and  $I_c^*$ ) are obtained by multiplying this peak value ( $I_m$ ) by the three-unit sine vectors ( $U_a$ ,  $U_b$  and  $U_c$ ) in phase with the three source voltages. These unit sine vectors are obtained from the three sensed line to neutral voltages [9]. The reference grid neutral current ( $I_n^*$ ) is set to zero, being the instantaneous sum of balanced grid currents. Multiplication of magnitude  $I_m$  with phases ( $U_a$ ,  $U_b$ , and  $U_c$ ) results in the three phase reference supply currents ( $I_a^*$ ,  $I_b^*$ , and  $I_c^*$ ). The grid synchronizing angle ( $\Theta$ ) obtained from phase locked loop (PLL) is used to generate unity vector template as

### 2.3 HYSTERESIS CURRENT CONTROL:

The hysteresis current control (HCC) is the easiest control method to implement; it was developed by Brod and Novotny in 1985. The shunt APF is implemented with three phase current controlled VSI and is connected to the ac mains for compensating the current harmonics. The VSI gate control signals are brought out from hysteresis band current controller

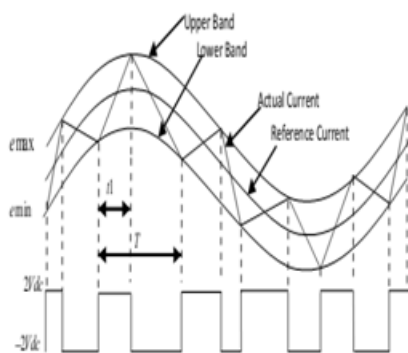

Fig:3 Waveform of Hysteresis current controller

A hysteresis current controller is implemented with a closed loop control system and waveforms are shown in Fig 4.4.

An error signal exceeds the upper limit of the hysteresis band, the upper switch of the inverter arm is turned off and the lower switch is turned on. As a result, the current starts decaying. If the error crosses the lower limit of the hysteresis band, the lower switch of the inverter arm is turned off and the upper switch is turned on. As a result, the current gets back into the hysteresis band. The minimum and maximum values of the error signal are  $e_{min}$  and  $e_{max}$  respectively. The range of the error signal  $e_{max} - e_{min}$  directly controls the amount of ripple in the output current from the VSI.

### 2.4 SIMULINK MODEL OF HYSTERESIS CURRENT CONTROL

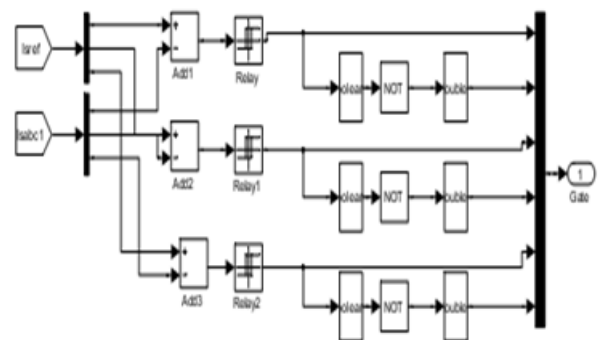

Fig. 4: Simulink Model of Hysteresis Current Control

### 2.5 MATLAB /SIMULINK MODEL OF PI CONTROL

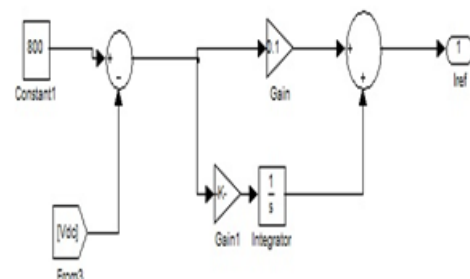

Fig.5: MATLAB Simulink model of PI control

**FUZZY SYSTEM:**

The fuzzy interface system Fuzzy system basically consists of a formulation of the mapping from a given input set to an output set using Fuzzy logic. The mapping process provides the basis from which the interference or conclusion can be made.

**A Fuzzy interface process consists of following steps**

Step 1: Fuzzification of input variables.

Step 2: Application of Fuzzy operator.(AND, OR, NOT) In the IF (antecedent) part of the rule.

Step 3: Implication from the antecedent to the consequent (Then part of the rule).

Step 4: Aggregation of the consequents across the rules.

Step 5: Defuzzification.

Generally there will be a matrix of rules similar tot eh ES rule matrix for Ex: There are 7MF for input variables ‘x’ and MF for input variable ‘y’ then there will be all together35 rules.

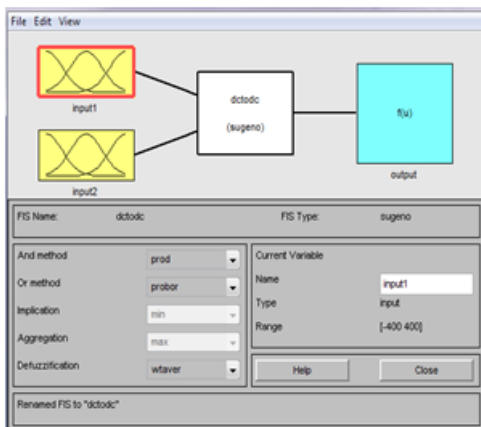

**Fig2.6 Fuzzy controller**

**IV. SIMULATION DESIGN:**

A simulation design open loop system as shown in Fig.7 is implemented in MATLAB SIMULINK

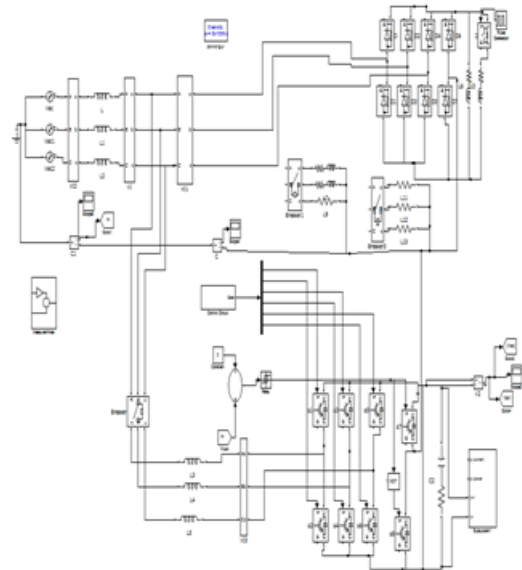

**Fig 7. Matlab Implementation**

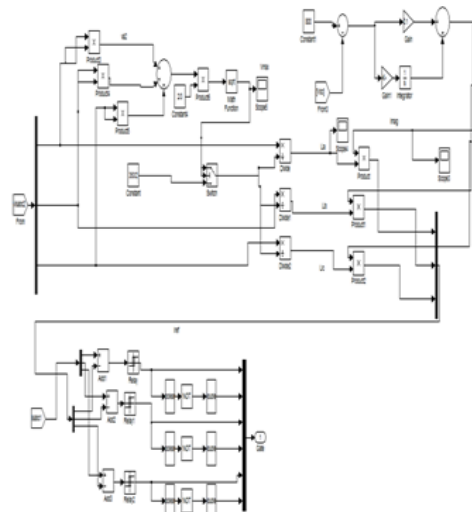

**Fig 8. Hysteresis With Pi Controller**

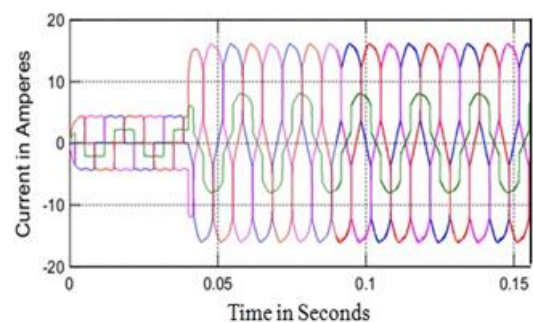

**Fig 9. Source Current Due To Non Linear Load**

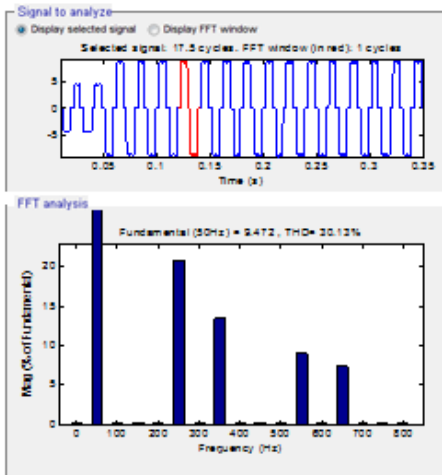

**Fig 10. THD Of Source Current Before Compensation**

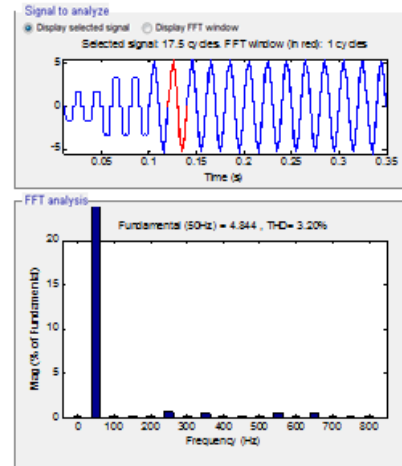

**Fig 12 Thd Of Source Current After Compensation**

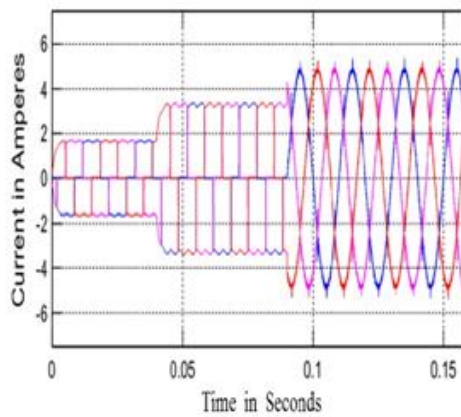

**Fig 11. Source Current With Filter**

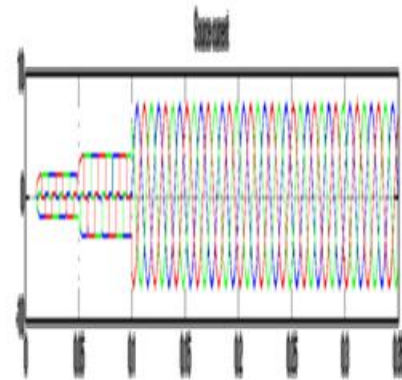

**Fig 13 Source Current With fuzzy**

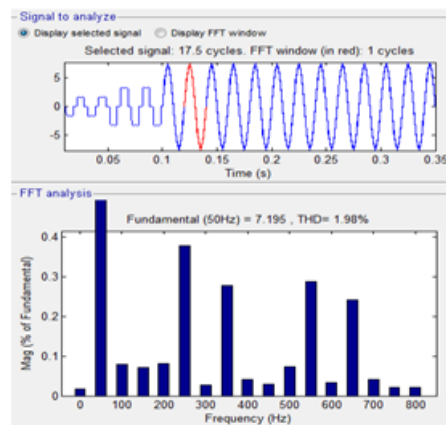
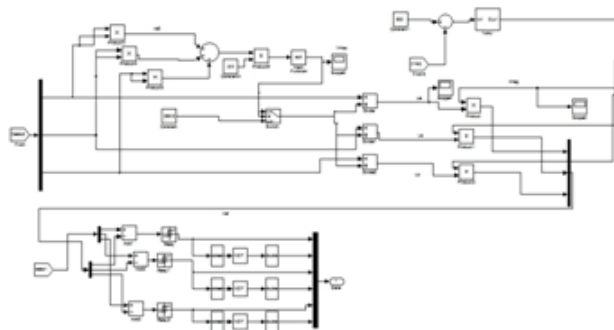

**Fig 15 THD Of Source Current With fuzzy**

S.NO	Source Current THD Without Inverter	Source Current THD With Inverter(PI Controller)	Source Current THD With Inverter(fuzzy Controller)
1	10	28.63	3.18

**Table 1: Comparison of THD's**

**V. CONCLUSION:**

The photovoltaic panel is modeled and connected to three phase four wire distribution system through an inverter. From the results, it can be concluded that the grid interfacing inverter is functioning as a conventional inverter as well as an Active Power Filter. It can also be concluded that the grid interfacing inverter is maintaining sinusoidal source current by reducing THD in supply under various load conditions. Pi controller and fuzzy controller is used for Inverter current control. It is better to use fuzzy controller by replacing pi controller.

**REFERENCES:**

[1] "A wireless controller to enhance dynamic performance of parallel inverters in distributed generation systems," IEEE Trans. Power Electron., vol. 19, no. 5, pp. 1205–1213, Sep. 2004.

[2] J. H. R. Enslin and P. J. M. Heskes, "Harmonic interaction between a large number of distributed power inverters and the distribution network," IEEE Trans. Power Electron., vol. 19, no. 6, pp. 1586–1593, Nov. 2004

[3] Singh.B, Chandra.A, Al-Haddad.K, "A review of active filters for power quality improvement," IEEE Trans. Industrial Electronics, Vol. 46, pp. 960-971, Oct. 1999

[4] POWER QUALITY: A UTILITY AND INDUSTRY PERSPECTIVE Jeff G. Dougherty, Member Duke Power Company P. O. Box 1006 Charlotte, NC 28201-1006 Wayne L. Stebbins, Senior

Member Hoechst Celanese Corporation 2850 Cherry Road Rock Hill, SC 29730-8998

[5] Ron A. Adams, Power Quality: A Utility Perspective, AEE Technical Conference Paper, October, 1996

[6] Special Feature: Power quality Solutions to the power quality problem by Prof. Ray Arnold

[7] L. Gyugi and E. C. Strycula, "Active AC Power Filters", IEEE-IAS Annual Meeting Record, 1976, pp. 529-535.

[8] V. Khadkikar, A. Chandra, A. O. Barry, and T. D. Nguyen, "Application of UPQC to protect a sensitive load on a polluted distribution network," in Proc. Annu. Conf. IEEE Power Eng. Soc. Gen. Meeting, 2006, pp. 867–872.

[9] Khadkikar V, Agarwal P, Chandra A, Barry A O and Nguyen T.D, "A simple new control technique for unified power quality conditioner (UPQC)", Harmonics and Quality of Power, 2004. 11th International Conference on 12- 15 Sept. 2004, pp. 289 – 293.