

Design and Development of Precision Agriculture Embedded Systems

Bosupally Ambica Sree

M.Tech(ES),

Raja Mahendra College of Engineering,
Hyderabad.

Bosupally Nanda Kumar, M.Tech, Ph.D,

HoD,

Raja Mahendra College of Engineering,
Hyderabad.

Abstract:

Agriculture continues to play a major role in Indian Economy. Agriculture Sector is changing the socio-economic environments of the population due to liberalization and globalization. Irrigation system in India has given a high priority in economic development. Many new concepts are being developed to allow agricultural automation to flourish and deliver its full potential. To take full advantage of these technologies, we should not just consider the implication of developing a new single technology but should look at the wider issues for complete development of a system.

INTRODUCTION

This paper deals with Real time atomization of agricultural environment for social modernization of Indian agricultural system using ARM7 and GSM is focused on automizing the irrigation system for social welfare of Indian agricultural system. The project is implemented by using advanced processor ARM7TDMI which is a 32 bit microprocessor, GSM serves as an important part as it is responsible for controlling the irrigation on field and sends them to the receiver through coded signals. GSM operates through SMSs and is the link between ARM processor and centralized unit.

ARM7TDMI is an advanced version of microprocessors and forms the heart of the system. Our project aims to implement the basic application of automizing the irrigation field by programming the components and building the necessary hardware. This project is used to find the exact field condition. GSM is used to inform the user about the exact field

condition. The information is given on user request in form of SMS. GSM modem can be controlled by standard set of AT (Attention) commands. These commands can be used to control majority of the functions of GSM modem.

In this project we are using LPC2148, Temperature sensor, Dry/wet sensor to detect the soil moisture condition automatically and 16X2 LCD is used to display their values with the help of in built Analog to digital converter and the people can access the information of sensors with the help of simple SMSs by using GSM technology. An ac motor is also connected to get the water when ever dry condition is detected.

This project uses two power supplies, one is regulated 5V for modules and other one is 3.3V for LPC2148. 7805 three terminal voltage regulator is used for voltage regulation. Bridge type full wave rectifier is used to rectify the ac output of secondary of 230/12V step down transformer.

Block Diagram:

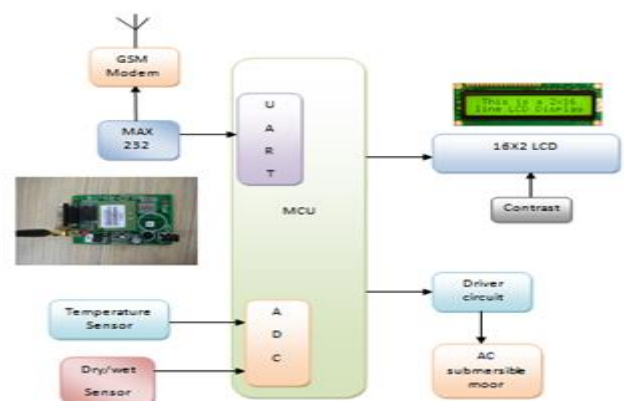

The LPC2148 are based on a 16/32 bit ARM7TDMI-ST[™] CPU with real-time emulation and embedded trace support, together with 128/512 kilobytes of embedded high speed flash memory. A 128-bit wide memory interface and unique accelerator architecture enable 32-bit code execution at maximum clock rate. For critical code size applications, the alternative 16-bit Thumb Mode reduces code by more than 30% with minimal performance penalty. With their compact 64 pin package, low power consumption, various 32-bit timers, 4- channel 10-bit ADC, USB PORT, PWM channels and 46 GPIO lines with up to 9 external interrupt pins these microcontrollers are particularly suitable for industrial control, medical systems, access control and point-of-sale. With a wide range of serial communications interfaces, they are also very well suited for communication gateways, protocol converters and embedded soft modems as well as many other general-purpose applications.

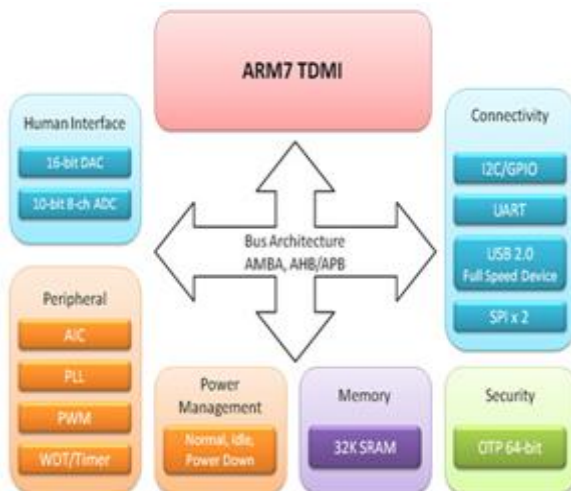

ARM PROCESSOR

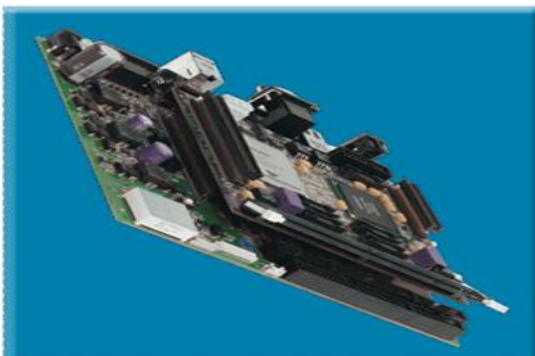

ARM7TDMI Processor Core

- Current low-end ARM core for applications like digital mobile phones
- TDMI
 - T: Thumb, 16-bit compressed instruction set
 - D: on-chip Debug support, enabling the processor to halt in response to a debug request
 - M: enhanced Multiplier, yield a full 64-bit result, high performance
 - I: Embedded ICE hardware
- Von Neumann architecture



Dry and Wet sensor

Soil moisture sensors measure the water content in soil. A soil moisture probe is made up of multiple soil moisture sensors. One common type of soil moisture sensors in commercial use is a Frequency domain sensor such as a capacitance sensor. Another sensor, the neutron moisture gauge, utilize the moderator properties of water for neutrons. Cheaper sensors - often for home use- are based on two electrodes measuring the resistance of the soil. Sometimes this simply consists of two bare (galvanized) wires, but there are also probes with wires embedded in gypsum. Measuring soil moisture is important in agriculture to help farmers manage their irrigation systems more efficiently. Not only are farmers able to generally use less water to grow a crop, they are able to increase yields and the quality of the crop by better management of soil moisture during critical plant growth stages.

Besides agriculture, there are many other disciplines using soil moisture sensors. Golf courses are now using sensors to increase the efficiencies of their

irrigation systems to prevent over watering and leaching of fertilizers and other chemicals offsite.

LM35 (temperature sensor)

A sensor is a device that measures a physical quantity and converts it into a signal which can be read by an observer or by an instrument.

The output of the lm 35 temperature sensor is in millivolts (mv). Connect the Vcc Pin to 5v and GND to GND, output of the lm 35 temperature sensor is in the analog form, to convert this into digital form we are going to use analog to digital converter.

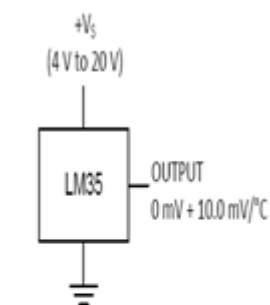
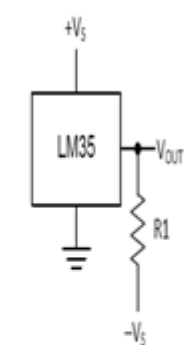

Figure 1. Basic Centigrade Temperature Sensor (+2°C to +150°C)



Choose $R_1 = -V_s / 50 \mu A$
 $V_{out} = 1500 \text{ mV at } 150^\circ C$
 $V_{out} = 250 \text{ mV at } 25^\circ C$
 $V_{out} = -550 \text{ mV at } -55^\circ C$

Figure 2. Full-Range Centigrade Temperature Sensor

Global System for Mobile Communication (GSM)

Definition:

GSM, which stands for Global System for Mobile communications, reigns (important) as the world's most widely used cell phone technology. Cell phones use a cell phone service carrier's GSM network by

searching for cell phone towers in the nearby area. Global system for mobile communication (GSM) is a globally accepted standard for digital cellular communication.

GSM is the name of a standardization group established in 1982 to create a common European mobile telephone standard that would formulate specifications for a pan-European mobile cellular radio system operating at 900 MHz. It is estimated that many countries outside of Europe will join the GSM partnership.



MODEM SPECIFICATIONS:

The SIM300 is a complete Tri-band GSM solution in a compact plug-in module.

Featuring an industry-standard interface, the SIM300 delivers GSM/GPRS900/1800/1900Mhz performance for voice, SMS, data and Fax in a small form factor and with low power consumption.

The leading features of SIM300 make it deal for virtually unlimited application, such as WLL applications (Fixed Cellular Terminal), M2M application, handheld devices and much more.

1. Tri-band GSM/GPRS module with a size of 40x33x2.85
2. Customized MMI and keypad/LCD support
3. An embedded powerful TCP/IP protocol stack

4. Based upon mature and field proven platform, backed up by our support service, from definition to design and production.

General Features:

- Tri-band GSM/GPRS900/1800/1900Mhz
- GPRS multi-slot class 10
- GPRS mobile station class –B
- Complaint to GSM phase 2/2+
 - i. -class 4(2W @900MHz)
 - ii. -class 1(1W @/18001900MHz)
- Dimensions: 40x33x2.85 mm
- Weight: 8gm
- 7. Control via AT commands
- (GSM 07.07, 07.05 and SIMCOM enhanced AT commands)
- SIM application tool kit
- supply voltage range 3.5.....4.5 v
- Low power consumption
- Normal operation temperature: -20 °C to +55 °C
- Restricted operation temperature: -20 °C to -25 °C and +55 °C to +70 °C
- Storage temperature: -40 °C to +80 °C

ADVANTAGES:

1. Ease of maintenance
2. Less power consumption
3. Very faster communication

APPLICATIONS:

1. Industrial Automation
2. Weather stations
3. Home Automation

References

1. A. Tyagi, A. A. Reddy, J. Singh, and S. R. Choudhari, A low cost temperature moisture sensing unit with artificial neural network based signal conditioning for smart irrigation applications, International Journal on Smart Sensors and Intelligent Systems, vol. 4, no. 1, pp. 94-111, 2011
2. J. F. Posada, J. J. Liou, and R. N. Miller, An automated data acquisition system for modelling the characteristic of a soil moisture sensor, IEEE Trans. on Instrumentation and Measurement, vol. 40, no. 5, pp. 836-841, 1991
3. M. Dursun and S. Ozden, A wireless application of drip irrigation automation supported by soil moisture sensors, Scientific Research and Essays, vol. 6, no. 7, pp. 1573-1582, 2011
4. T. NITTA and S. HAYAKAWA, Ceramic humidity sensors, IEEE Transactions on Components, Hybrid and Manufacturing Technology, vol. 3, no. 2, pp. 237-243, 1980
5. C. Liu, W. Ren, B. Zhang, and C. Lv, The application of soil temperature measurement by Im35 temperature sensors, International Conference on Electronic and Mechanical Engineering and Information Technology, vol. 88, no. 1, pp. 1825-1828, 2011
6. B. Feng, Z. Wang, J. Zhang, and W. Wang, Theory and experiment on temperature effect in soil,





Northwest Water Resources and Water Engineering,
vol. 12, no. 4, pp. 6-11, 2001

7. X. Qiao, X. He, X. Du, H. Tian, and C. Wang,
Design and implement of multi-point soil temperature
measurement, Journal of Shenyang Agricultural
University, vol. 37, no. 3, pp. 278-281, 2006

8. Y. Song, J. Wang, X. Qiao, W. Zheng, and X.
Zhang, Development of multi-functional soil
temperature measuring instrument, Journal of Agricul-
tural Mechanization Research, vol. 9, no. 1, pp. 80-84,
2010

9. R. G. Luis, L. Loradana, B. Pilar, and I. R. Jose, A
review of wireless technologies and applications in
agriculture and food industry: State of the art and
current trends, Sensors, vol. 9, no. 1, pp. 4728-4750,
2009

10. C. A., Lopez-Baeza, J. L. Anon, C. Reig, and C.
Millan-Scheidig, A wireless sensor network for soil
moisture applications, International Conference on
Sensor Technologies and Applications, vol. 7, no. 7,
pp. 508-513, 2007