

## Performance Analysis of BER in Wavelet-OFDM under Various Channels For 4G Wireless Communications

**Godudunuri Mastan Reddy**

M.Tech (CESP),  
Department of ECE

PNC & VIJAI Institute of Engineering & Technology,  
Repudi, Phirangipuram,  
Andhrapradesh, India.

**M. Rajan**

Associate Professor & HoD,  
Department of ECE

PNC & VIJAI Institute of Engineering & Technology,  
Repudi, Phirangipuram,  
Andhrapradesh, India.

### ABSTRACT

Rapidly growing technology has made it possible for the communication systems to transfer data almost everywhere on this planet. But the limited bandwidth allocated to a large number of users restricts the bandwidth availability to the users. This scenario creates a technological challenge to develop the data transmission schemes which are bandwidth efficient. Multicarrier modulation is such a scheme that transmits the data by dividing the serial high data rate streams into a number of low data rate parallel data streams. Orthogonal Frequency Division Multiplexing (OFDM) is a kind of multi-carrier modulation, which divides the available spectrum into a number of parallel subcarriers and each subcarrier is then modulated by a low rate data stream at different carrier frequency. Wavelet based OFDM provides a good orthogonality and with its use Bit Error Rate (BER) will be well reduced over conventional OFDM systems. Therefore, this can be used in long term evaluation (LTE) networks i.e., 4G wireless communication network. Wavelet based system does not require cyclic prefix hence spectrum efficiency will be increased. It is proposed to use the wavelet based OFDM at the place of Discrete Fourier Transform (DFT) based OFDM in LTE. We have compared the BER performance of wavelets based OFDM using different channel environments. Simulation results have been compared with conventional DFT-OFDM system and had shown

*that the wavelet based OFDM has got much reduced BER*

**Keywords** – OFDM, DFT, wavelets, LTE and BER

### INTRODUCTION

OFDM with the rapid growth in technology, the demand for flexible high data-rate services has also increased. The performance of high data rates communication systems is limited by frequency selective multipath fading which results in inter symbol interference (ISI). In the wireless channels, impairments such as fading, shadowing and interferences due to multiple user access highly degrade the system performance. . Multicarrier modulation (MCM) is a solution that overcomes these problems in wireless channels. It is the technique of transmitting data that divides the serial high data rate streams into a large number of low data rate parallel data streams [1]. Orthogonal Frequency Division Multiplexing (OFDM) is a kind of multi-carrier modulation, which divides the available spectrum into a number of parallel subcarriers and each subcarrier is then modulated by a low rate data stream at different carrier frequency. The conventional OFDM system makes use of IFFT and FFT for multiplexing the signals and reduces the complexity at both transmitter and receiver [2]. OFDM is comprised of a blend of modulation and multiplexing. The original data signal is split into many independent signals, each of which is modulated at a different frequency and then

these independent signals are multiplexed to create an OFDM carrier. As all the subcarriers are orthogonal to each other, they can be transmitted simultaneously over the same bandwidth without any interference which is an important advantage of OFDM [3]. OFDM makes the high speed data streams robust against the radio channel impairments. OFDM is an efficient technique to handle large data rates in the multipath fading environment which causes ISI. With the help of OFDM, a large number of overlapping narrowband subcarriers, which are orthogonal to each other, are transmitted parallel within the available transmission bandwidth. Thus, in OFDM, the available spectrum is utilized efficiently. With the rapidly growing technology, the demands for high speed data transmission are also increasing. OFDM is a multicarrier modulation technique which has the capability to fulfil this demand for large capacity. OFDM is reliable and economical to handle the processing power of digital signal processors. OFDM is used in many applications such as IEEE 802.11 wireless standard, Cellular radios, GSTN (General Switched Telephone Network), DAB (Digital Audio Broadcasting), DVB-T (Terrestrial Digital Video Broadcasting) [3], HDTV broadcasting, DSL [4] and ADSL modems and HIPERLAN type II (High Performance Local Area Network) [4].

### OFDM SYSTEM

OFDM is a special form of Multi Carrier Modulation (MCM) with densely spaced sub carriers with overlapping spectra, thus allowing for multiple-access. MCM is the principle of transmitting data by dividing the stream into several bit streams, each of which has a much lower bit rate, and by using these sub-streams to modulate several carriers. This technique is being investigated as the next generation transmission scheme for mobile wireless communications networks.

### Orthogonality

In geometry, orthogonal means, "involving right angles" (from Greek ortho, meaning right, and gon meaning angled). The term has been extended to general use, meaning the characteristic of being independent (relative to something else). It also can mean: non-redundant, non-

overlapping, or irrelevant. Orthogonality is defined for both real and complex valued functions [2]. The functions  $\varphi_m(t)$  and  $\varphi_m^*(t)$  are said to be orthogonal with respect to each other over the interval  $a < t < b$  if they satisfy the condition[3].

$$\int_a^b \varphi_m(t) \varphi_m^*(t) dt = 0,$$

### OFDM Carriers

As for mentioned, OFDM is a special form of MCM and the OFDM time domain waveforms are chosen such that mutual Orthogonality is ensured even though sub-carrier spectra may over-lap. With respect to OFDM, it can be stated that Orthogonality is an implication of a definite and fixed relationship between all carriers in the collection. It means that each carrier is positioned such that it occurs at the zero energy frequency point of all other carriers. The sinc function, exhibits this property and it is used as a carrier in an OFDM system [3]. Orthogonal Frequency Division Multiplexing (OFDM) is a kind of multi-carrier modulation, which divides the available spectrum into a number of parallel subcarriers and each subcarrier is then modulated by a low rate data stream at different carrier frequency which is given in [7] as equation

$$\int_0^T \cos(2\pi f_n t) \cos(2\pi f_m t) dt = \delta(n-m),$$

Where  $(n-m)$  is the Dirac Delta function.

These subcarriers become orthogonal to each other when two different subcarrier waveforms are multiplied and integrated over symbol period results into zero.

OFDM (Orthogonal Frequency Division Multiplexing) is one kind of the techniques of MCM (Multi-Carrier Modulation), which belongs to the field of wireless communication. The basic idea of MCM is to modulate signals onto many carriers and then combine these signals to transmit out (figure 1). The modulation system has S/P converter, which converts the high rate serial data into lower rate paralleled data. Due to the lower rate data has longer time duration, which is usually far larger than the maximum delay of the signal transmitting channel, thus makes it possible to well-combat multi-path effect and

easy to equalization at the receiver. But MCM also has a disadvantage. If the number of carrier N is large, then the whole system needs a wide band of frequency.

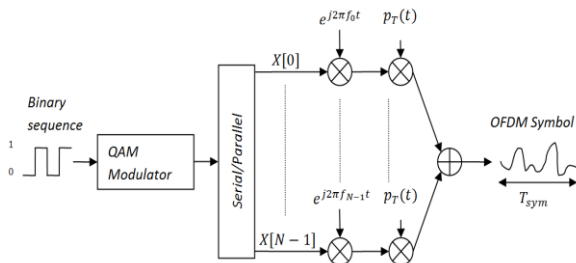

Fig.1 Multi-Carrier Modulation

OFDM contributes on the frequency saving. It chooses a group of sub-carriers which are orthogonal to each other at the time domain, but they are overlapped in the frequency domain (see figure 2), which is different from MCM stated above (guarantee no overlapped in frequency domain by guard). In this way, although they are overlapped, they are orthogonal to each other and thus can be separated at the receiver.

We first write out the modulated signal as:

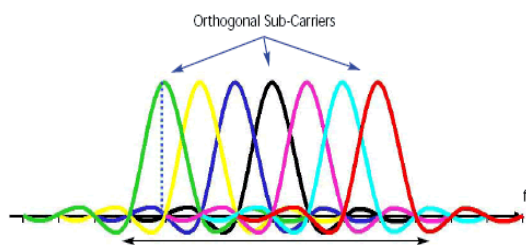

Fig.2 Overlapped frequency in OFDM

$$S = \sum_{i=0}^{N-1} d(i)e^{j\omega_i t}$$

where  $\omega_i$  is the frequency of sub-carrier i. Suppose the time duration after S/P is T, before S/P is t0.

So we have  $T = Nt_0$ . We choose the sub-carrier frequency by

$$\omega(i) = \omega(0) + \frac{1}{T} = \omega(0) + \frac{2\pi i}{Nt_0}$$

So that we can represent modulated signal as:

$$S = \sum_{i=0}^{N-1} d(i)e^{j\frac{2\pi i}{Nt_0}t} e^{j\omega(0)t}$$

### PROBLEM DEFINITION

Wavelet based OFDM is found to be an efficient method to replace FFT based OFDM systems as wavelets has many advantages as compared to FFT-OFDM. DWT based OFDM has the potential to decrease the hardware complexity because Cyclic Prefix is not required in this case and proposed system gives nearly perfect reconstruction. . DWT is an effective tool to study the signals in time frequency joint domain as it has the ability to provide simultaneous information about time and frequency, thereby gives the time frequency representation of the signal. It has been found that wavelets have compact localization in both time domain and frequency domain and have better orthogonality. DWT based OFDM has the ability to combat the narrowband interference as the wavelets possess high spectral containment properties; making the system more robust against inter-carrier interference as compared to FFT realization. As cyclic prefix is not used in DWT OFDM, the data rates are better than that of FFT OFDM systems [16].

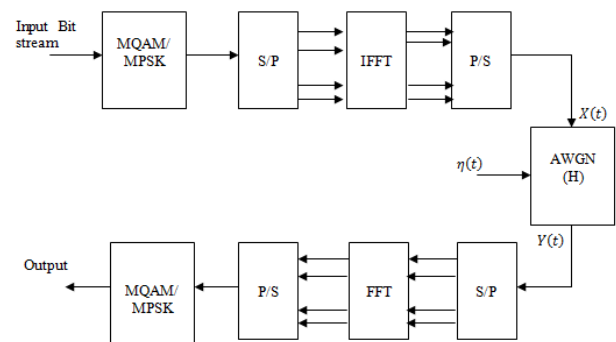

Fig. 3 DFT based OFDM system

Wavelet based OFDM is employed in order to remove the use of cyclic prefix which decreases the bandwidth wastage and the transmission power is also reduced by the use of wavelet transform. The spectral containment of the channels in DWT-OFDM is also better than the FFT-OFDM. Discrete wavelet transform is a type of wavelet transform which is found to be an alternative approach to replace IFFT and FFT in OFDM systems. In Wavelet transform, the desired signal is decomposed into set of basis waveforms, known as wavelets, which provide the way for analyzing the signals by investigating the



coefficients of wavelets. DWT is used in several applications and has become very popular among engineers, technologists and mathematicians. The basis functions of wavelet transform are localized both in time and frequency and possess different resolutions in both domains which makes the wavelet transforms a powerful tool in various applications. Different resolutions correspond to analyze the behaviour of the process and the power of the transform. Due to these properties, the wavelets and wavelet transform find their applications in various fields such as data compression, image compression, radar, computer graphics and animation, astronomy, human vision, nuclear engineering, acoustics, biomedical engineering, music, seismology, turbulence, magnetic resonance imaging, fractals and pure mathematics. Since wavelet transform has many advantages such as flexibility, lesser sensitivity against channel distortion and interference as well as better utilization of spectrum, it has been proposed to design the sophisticated wireless communication systems [16]. Wavelets are beneficial in various aspects such as channel modelling, data representation, transceiver design, and source and channel coding, data compression, interference minimization, energy efficient networking and signal de-noising in wireless communication systems. A low pass filter and high pass filter is employed to operate as QMF and satisfies perfect reconstruction and ortho-normal properties. In wavelet based OFDM, the modulated signal is transmitted using zero padding and vector transposing. DWT is known as a flexible and highly efficient method for decomposition of signals.

### WAVELETS

A wavelet is a small waveform that has effectively limited duration having an average value of zero. Wavelets have limited duration and tend to be asymmetric and irregular. The wavelet analysis consists of breaking up a signal into scaled and shifted versions of the original signal or mother wavelet. Wavelets are a class of functions used to localize a given function in both space and scaling. A family of wavelets can be constructed from a function  $\psi(x)$ , sometimes known as a "mother wavelet," which is confined in a finite interval

Daughter wavelets  $\psi_{\tau, S}(x)$ , are then formed by translation (S) and contraction ( $\tau$ ). Wavelets are especially useful for compressing image data, since a wavelet transform has properties which are in some ways superior to a conventional Fourier transform.

$$W(\tau, s) = \int_0^T x(t) \cdot \psi\left(\frac{t-\tau}{s}\right) e^{-j\omega t} dt$$

$x(t)$ =actual time series,  $\psi(t)$ =wavelet function

Wavelet properties which are in some ways superior to a conventional Fourier transform. The channel model can be AWGN, Rayleigh or any other channel. To generate an OFDM symbol, the channel encoding of serial data stream is done followed by modulating the symbol using any modulation scheme. To successfully generate OFDM, the relationship among all the carriers must be controlled carefully to sustain the orthogonality of the carriers. Due to this, OFDM symbol is generated choosing the spectrum required firstly, based on the input data, and modulation scheme used. Some data is assigned to each carrier to be produced to transmit. The required amplitude and phase of the carrier is then calculated based on the modulation scheme which is typically differential BPSK, QPSK, or QAM. DWT based OFDM is an efficient approach to replace FFT in conventional OFDM systems. DWT is employed in order to remove the use of cyclic prefix which decreases the bandwidth wastage and the transmission power is also reduced by the use of wavelet transform. The spectral containment of the channels in DWT-OFDM is better than FFT-OFDM. In Wavelet transform, the signal of interest is decomposed into set of basis waveforms, known as wavelets, which provide the way for analyzing the signals by investigating the coefficients of wavelets.

### DWT-OFDM SYSTEM

DWT based OFDM is an efficient approach to replace FFT in conventional OFDM systems. DWT is employed in order to remove the use of cyclic prefix which decreases the bandwidth wastage and the transmission power is also reduced by the use of wavelet transform. The spectral containment of the channels in DWT-OFDM is better than FFT-OFDM. In Wavelet transform, the signal of interest is decomposed into set of basis

waveforms, known as wavelets, which provide the way for analyzing the signals by investigating the coefficients of wavelets. DWT is used in several applications and has become very popular among engineers, technologists and mathematicians. The basic functions of wavelet transform are localized both in time and frequency and possess different resolutions in both domains which makes the wavelet transforms a powerful tool in various applications. Different resolutions correspond to analyze the behaviour of the process and the power of the transform.

Due to these properties, the wavelets and wavelet transform find their applications in various fields such as data compression, image compression, radar, computer graphics and animation, astronomy, human vision, nuclear engineering, acoustics, biomedical engineering, music, seismology, turbulence, magnetic resonance imaging, fractals and pure mathematics. Since wavelet transform has many advantages such as flexibility, lesser sensitivity against channel distortion and interference as well as better utilization of spectrum, it has been proposed to design the sophisticated wireless communication systems [25]. Wavelets are beneficial in various aspects such as channel modelling, data representation, transceiver design, and source and channel coding, data compression, interference minimization, energy efficient networking and signal denoising in wireless communication systems. DWT is known as a flexible and highly efficient method for decomposition of signals. Since wavelet transform has many advantages such as flexibility, lesser sensitivity against channel distortion and interference as well as better utilization of spectrum, it has been proposed to design the sophisticated wireless communication systems. DWT is known as a flexible and highly efficient method for decomposition of signals.

The data generator first generates a serial random data bits stream. This data stream is passed through the bit-to-symbol mapper to convert it into a symbol and then the data is processed using modulator to map the input data based on the modulation technique used. The DWT-OFDM symbol  $s(t)$  can be represented as equation given below

$$s(t) = \sum_{j \in J} \sum_k w_{jk}(t) \psi_{jk}(t) + \sum_k a_{jk} \phi_{jk}$$

The orthogonality of these carriers relies on time location (k) and scale index (j). This symbol is clearly the weighted sum of wavelet and scale carriers which is similar to the Inverse Wavelet Transform (IDWT). In DWT-OFDM, the input data is processed same as in FFTOFDM but the advantage in this case is that the cyclic prefix is not required because of the overlapping nature of wavelet properties. The data is processed in the IDWT block whose output can be given as equation given below.

$$d(k) = \sum_{n=0}^m \sum_{m=0}^n D_n^m 2^{\frac{m}{2}} \psi(2^{\frac{m}{2}}/k - n)$$

where  $k$  is the number of subcarriers ( $0 \leq k \leq N - 1$ ),  $Dm$   $n$  are the wavelet coefficients which represents the signal in scale and position on time-axis and  $\psi(t)$  is the wavelet function with compressed factor  $m$  times and shifted  $n$  times for each subcarrier.

The block diagram of wavelets based OFDM is shown below:

At the receiver side, the process is reversed. The output of discrete wavelet transform (DWT) is represented by equation

$$D_n^m = \sum_{k=0}^{N-1} d(k) 2^{\frac{m}{2}} \psi(2^{\frac{m}{2}} - n)$$

The Discrete Wavelet Transform is used in a variety of signal processing applications, such as Internet communications compression video compression, object recognition and numerical analysis. The main advantage of wavelet transform over Fourier transform is that it is discrete both in time as well as scale.

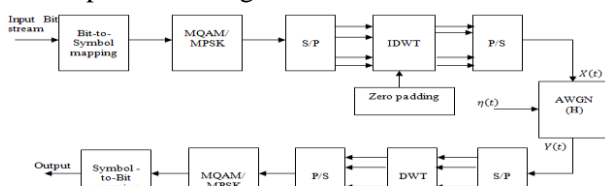

Fig.4 DWT based OFDM system with AWGN channel

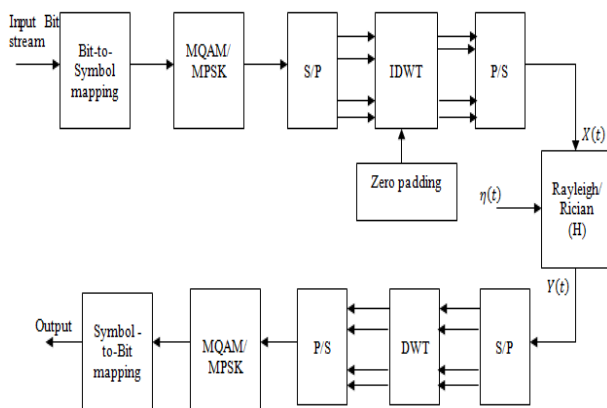

Fig. 5 DWT based OFDM system with Rayleigh and Rician channels

## MATHEMATICAL ANALYSIS

### Rayleigh Fading

Rayleigh fading is caused by multipath reception. The mobile antenna receives a large number, say  $N$ , reflected and scattered waves. Because of wave cancellation effects, the instantaneous received power seen by a moving antenna becomes a random variable, dependent on the location of the antenna. To simplify the derivation of the fading models an un-modulated carrier of the form  $s(t) = A \cos(2\pi f_c t)$  as transmission signal is used. Based on the block diagram the complex envelope of the received signal is:

$$\hat{s}(t) = A \sum_{i=0}^{D-1} a_i(t) \cos \{2\pi f_c [t - \tau_i(t)]\}$$

where  $a_i(t)$  is the gain factor and  $\tau_i(t)$  is the delay for a specific path  $i$  at a specific time  $t$ .

$$\hat{s}(t) = A r_{Ra}(t) \cos [2\pi f_c t + \varphi_{Ra}(t)]$$

Where  $r_{Ra}(t)$  is a sample function of a Rayleigh distributed random process:

$$P(r_{Ra}) = \frac{r_{Ra}}{\sigma^2} \exp\left(-\frac{r_{Ra}^2}{2\sigma^2}\right)$$

and the  $\varphi_{Ra}(t)$  is uniformly distributed in the interval  $[0, 2\pi)$ .

The general form of this channel model is:

$$\hat{s}(t) = \text{Re} \{r_{Ra}(t) e^{j2\pi\varphi_{Ra}(t)} s_{bb}(t) e^{j2\pi f_c t}\}$$

Again,  $r_a(t)$  and  $\varphi_{Ra}(t)$  are amplitude and phase from a particular measurement of a Rayleigh distributed random process. This channel is called Rayleigh fading channel.

### Rician Fading Channel

The model behind Rician fading is similar to that for Rayleigh fading, except that in Rician fading a strong

dominant component is present. This dominant component can for instance be the line-of-sight wave. Refined Rician models also consider

- That the dominant wave can be a phasor sum of two or more dominant signals, e.g. the line-of-sight, plus a ground reflection. This combined signal is then mostly treated as a deterministic (fully predictable) process
- That the dominant wave can also be subject to shadow attenuation. This is a popular assumption in the modeling of satellite channels. Besides the dominant component, the mobile antenna receives a large number of reflected and Scattered waves.

A Rician fading channel indicates that there is a prominent or direct path over which the electromagnetic wave can travel. Compared to the Rayleigh channel model, Equation 1, the Rician fading channel model has an additional  $s(t) = A \cos(2\pi f_c t)$  component to reflect the prominent path:

$$\hat{s}(t) = A \cos(2\pi f_c t) + \sum_{i=0}^{D-1} a_i(t) \cos \{2\pi f_c [t - \tau_i(t)]\}$$

Above Equation can be written as:

$$\hat{s}(t) = A r_{Ri}(t) \cos[2\pi f_c t + \varphi_{Ri}(t)]$$

Where  $r_{Ri}(t)$  is a sample function of a random process with a Rician distributed probability density function (pdf):

$$P(r_{Ri}) = \frac{r_{Ri}}{\sigma^2} \exp\left(-\frac{r_{Ri}^2 + A^2}{2\sigma^2}\right) I_0\left(\frac{Ar_{Ri}}{\sigma^2}\right)$$

Where  $I_0$  is the zero order modified Bessel functions of the first kind given by:

$$I_0(x) = \frac{1}{2\pi} \int_0^{2\pi} \exp[x \cos(\varphi)] d\varphi$$

and the distribution of  $\varphi_{Ri}(t)$  is:

$$P(\varphi_{Ri}) = \frac{1}{2\pi\sigma^2} \exp\left(-\frac{A^2}{2\sigma^2}\right) \left\{ \sigma^2 + \right.$$

$$\left. \frac{A}{2} \sqrt{2\pi\sigma^2} \cos(\varphi_{Ri}) \exp\left(\frac{A^2 \cos^2 \varphi_{Ri}}{2\sigma^2}\right) \left[1 + \text{erf}\left(\frac{A \cos \varphi_{Ri}}{2\sigma^2}\right)\right] \right\}$$

Where  $\text{erf}(x)$  is the error function defined as:

$$\text{erf}(x) = \frac{2}{\pi} \int_0^x \exp(-t^2) dt$$

The ratio  $K = \frac{\Lambda^2}{\sigma^2}$ , referred as the K-factor, relates the power in un faded and faded components. Values of  $K \gg 1$  indicate less severe fading, whereas  $K \ll 1$  indicates severe fading.

The general form of the Rician channel model is:

$$\hat{S}(t) = \text{Re} \{ r_{Ri}(t) e^{j2\pi\phi_{Ri}(t)} s_{bb}(t) e^{j2\pi f_c t} \}$$

Where  $r_{Ri}(t)$  and  $\phi_{Ri}(t)$  are amplitude and phase of a particular measurement of a rician distributed random process.

### PERFORMANCE EVALUATION

Simulations have been done in MATLAB 2014a version with 4 GB RAM. We tested the conventional and proposed scheme with various modulation levels that are used for the LTE. Modulations that could be used for LTE are 4 QAM, 16 QAM and 32 QAM (Uplink and downlink). For the purpose of simulation, signal to noise ratio (SNR) of different values are introduced through AWGN, RAYLEIGH, RICIAN channel. Data of 10,000 bits is sent in the form of 100 symbols, so one symbol is of 100 bits. Averaging for a particular value of SNR for all the symbols is done and BER is obtained and same process is repeated for all the values of SNR and final BERs are obtained. Using MATLAB Figure below shows the comparison of BER performance for conventional OFDM (DWT - OFDM) using different modulation techniques. This figure shows the relationship between BER and SNR. The values of SNR are from 0 db to 25 db and the scale of SNR is linear.

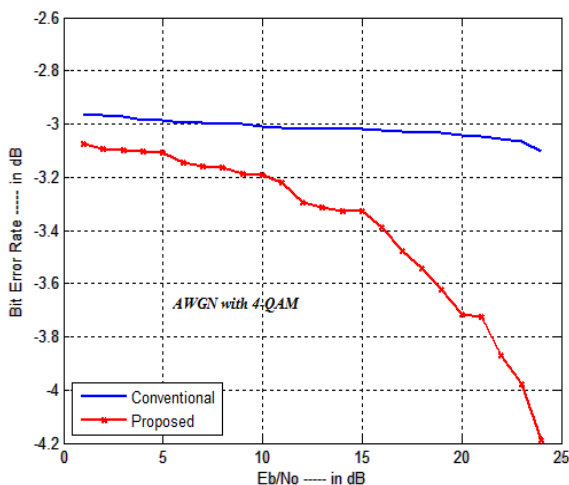

Fig.6 BER performance of proposed and conventional system with AWGN and 4-QAM

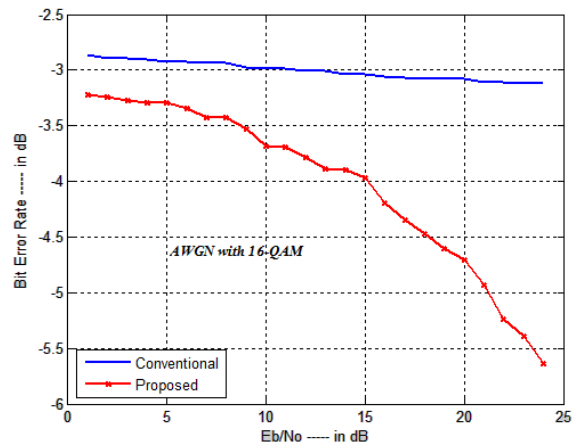

Fig. 7 BER performance of proposed and conventional schemes with AWGN and 16-QAM

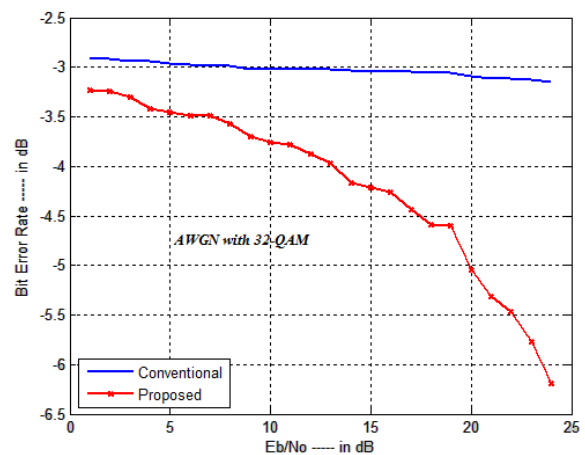

Fig.8 BER performance of proposed and conventional system with AWGN and 32-QAM

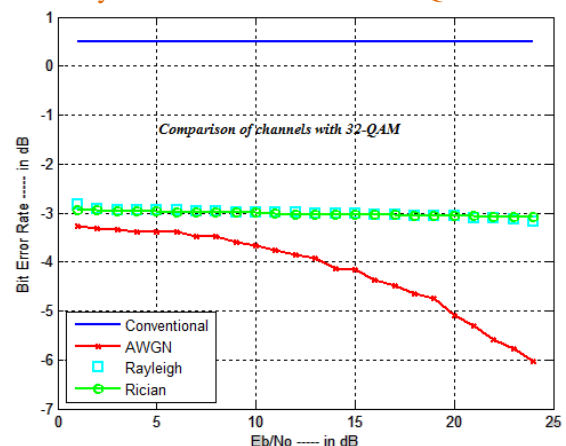

Fig.9 BER performance of proposed and conventional system with 32-QAM under AWGN, Rayleigh and Rician channels



## CONCLUSION

This paper compares the performance of Fourier transform based and Wavelet based OFDM systems in terms of bit error rate probability for different channels scenarios. From the performed simulations in the Rician channel, it was found that the DWT based OFDM system has better performance than that of the FFT-OFDM for the modulations used viz. QPSK or QAM. It was also found that DWT-OFDM outperformed FFT-OFDM in other types of channels i.e. Rayleigh and Rician fading channels also. Wavelet based system was found having small bit error rate probability than that of the Fourier transform based system. The purpose of the research was to implement and find the transform that performs better in the wireless channels that are mostly multipath.

The paper compares the performance of the systems using QAM or QPSK whereas the future work may include the implementation of other modulation schemes and different channel scenarios for performance evaluation of any OFDM based system. We used Three modulation techniques for implementation that are 4 QAM, 16 QAM, 32 QAM. In wavelet based OFDM different types of filters can be used with the help of different wavelets available, they provide their best performances at different intervals of SNR. And we conclude that the BER curves obtained from wavelet based OFDM are better than that of DFT based OFDM. Moreover, the cyclic prefix is not used in DWT based OFDM system. The simulation results show that when the DWT-OFDM system is used with Convolutional encoding, the BER performance of the system is improved in AWGN as well as Rician channel. This is because the Convolutional codes are very effective in removing the burst errors and distortions caused by the channel. Moreover, the BER performance of the system is affected by the outage probability. Outage probability is the probability when the required data rate is not supported by the specific channel due to variable SNR. The Convolutional encoding coupled with bit interleaving reduces the outage probability at higher SNR. Thus, the

DWT-OFDM system with encoding outperforms significantly at higher values of SNR. \

## REFERENCES

- [1] R.W. Klein, M.A. Temple, R.A. Raines, and R.L. Claypoole Jr., "Interference Avoidance Communications Using Wavelet Domain Transformation Techniques", IEEE Electronic Letters, vol. 37, no. 15, pp. 987-989, 2001.
- [2] G. Gowri, G. Uma Maheswari, E. Vishnupriya, S. Prabha, D. Meenakshi, N. R. Raajan, "Performance Analysis of DWT-OFDM and FFT-OFDM systems", International Journal of Engineering and Technology (IJET), vol. 5, no. 2, 2013.
- [3] Swati Sharma, Sanjeev Kumar, "BER Performance Evaluation of FFT-OFDM and DWT-OFDM", International Journal of Network and Mobile Technologies, vol. 2, issue 2, pp. 110-116, 2011.
- [4] Rohit Bodhe, Satish Narkhede, Shirish Joshi, "Design of Simulink Model for OFDM and Comparison of FFT-OFDM and DWT-OFDM", International Journal of Engineering Science and Technology, vol. 4, no. 5, pp. 1914-1924, 2012.
- [5] Achala Deshmukh, Shrikant Bodhe, "Comparison of DCT and Wavelet Based OFDM System Working in 60 GHz Band", International Journal of Advancements in Technology, vol. 3, no. 2, pp. 74-83, 2012.
- [6] M. B. Veena, M. N. Shanmukha Swamy, "Performance analysis of DWT based OFDM over FFT based OFDM and implementing on FPGA" International Journal of VLSI design & Communication Systems (VLSICS), vol.2, no. 3, 2011.
- [7] J. A. C. Bingham, "Multicarrier modulation for data transmission: An idea whose time has come," IEEE Communication Magazines, vol. 28, no. 5, pp. 5-14, 1990.
- [8] Bhasker Gupta, Gagan Gupta, and Davinder S. Saini, "BER Performance Improvement in OFDM System with ZFE and MMSE Equalizers", IEEE Communications Letters, vol. 6, no., pp. 193-197, April 2011.



- [9] L. Jun, T. T. Thiang, F. Adachi, H. C. Li, "BER performance of OFDM-MDPSK system in frequency selective rician fading and diversity reception" IEEE Transactions on Vehicular Technology, vol. 49, no. 4, pp. 1216-1225, July 2000.
- [10] K. A. Hasan, M. Waleed A., N. Saad, "The performance of multi wavelets based OFDM system under different channel conditions", Digital signal processing, Elsevier, vol. 20, no. 2, pp. 472- 482, March 2010.
- [11] K. Oguz, K. Volkan, "Alamouti coded wavelet based OFDM for multipath fading channels", IEEE Wireless telecommunications symposium, pp.1-5, April 2009.
- [12] G. M. Kumar, S. Tiwari, "Performance evaluation of conventional and wavelet based OFDM system", International journal of electronics and communications, Elsevier, vol. 67, no. 4, pp. 348-354, April 2013.
- [13] M. Petri , J. Antony, "Wavelet packet modulation for wireless communication", Wireless communication & mobile computing journal, vol. 5, no. 2, pp. 1-18, March 2005.
- [14] L. M. Kumar, N. Homayoun, "A review of wavelets for digital wireless communication", Wireless personal communications, Kluwer academic publishers- Plenum publishers, vol. 37, no. 3-4, pp. 387-420, May 2006.
- [15] L. Alan, "Wavelet packet modulation for orthogonally multiplexed communication", IEEE transaction on signal processing, vol. 45, no. 5, pp. 1336-1339, May 1997.
- [16] P. Gotz, U. Jorn , K. Werner, Z Georg, "A comparison of various MCM schemes", 5th International OFDMworkshop, Hamburg, Germany, pp. 20-1 – 20-5, July 2000.
- [17] IEEE std., IEEE proposal for 802.16.3, RM wavelet based (WOFDM), PHY proposal for 802.16.3, Rainmaker technologies, 2001.
- [18] O. Eiji, I Yasunori, I Tetsushi, "Multimode transmission using wavelet packet modulation and OFDM", IEEE vehicular technology conference, vol. 3, pp. 1458-1462, Oct. 2003.
- [19] L. Louis, P. Michael, "The principle of OFDM" RF signal processing, <http://www.rfdesign.com>, pp. 30-48, Jan 2001.
- [20] "LTE in a nutshell: The physical layer", white paper, 2010, <http://www.tsiwireless.com>.
- [21] R. Mika, T. Olav, "LTE, the radio technology path toward 4G", computer communications, Elsevier, vol. 33, no. 16, pp. 1894-1906, Oct. 2010.
- [22] Broughton SA, Bryan K. Discrete Fourier analysis and wavelets. New Jersey, John Wiley, 2009.

#### Author Details

**Godugunuri Mastan Reddy** received his B. Tech (ECE) Degree from Acharya Nagarjuna University in 2011. Currently he is pursuing M. Tech (CESP) in PNC & Vijai Institute of Engineering & Technology, Repudi, Phirangipuram, JNTU Kakinada (2013-15). His Interested research areas are OFDM and LTE networks

**Mr. M. Rajan** working as Associate Professor & H.O.D in P.N.C. & Vijai Institute of Engineering and Technology. Repudi, Phirangipuram, Guntur (dist). He received his B. Tech degree in Electronics and Communication Engineering from Prakasam Engineering college, Kandukur, affiliated to JNTUK, Kakinada, Andhra Pradesh, India in 2006. He did his M. Tech degree in the specialization of Communication & Signal Processing in the department of Electronics and Communication Engineering from Bapatla Engineering college, affiliated to Acharya Nagarjuna University, Nagarjunanagar, Guntur, Andhra Pradesh, India in 2008. He worked as a Senior Research Assistant at R&T Unit for Navigation Electronics, O.U, and Hyderabad from November 2007 to June 2008. He is a Member of Indian society for technical education (M.I.S.T). He has 8 years of teaching experience. He attended 6 Technical improvement programs in the area of communication, signal and image processing. He has strong knowledge in field of communications and signal processing.