

Railway Track Misalignment Detection Using Sensors and Wireless Communication

Kalvakurthi Shruthi

M.Tech Student,

Raja Mahendra College of Engineering,
Hyderabad.

G.Vijaya Padma, M.E, Ph.D,

Vice Principal,

Raja Mahendra College of Engineering,
Hyderabad.

Abstract:

The Transportation of train always depends on railway tracks (rails) only. If there is a crack in these rails, it creates a major problem. Most of the accidents in the train are caused due to cracks in the railway tracks, which cannot be easily identified. Also it takes more time to rectify this problem. In order to avoid this problem, we are using the crack detector robot, which detects the crack in the rails and gives an alarm.

A robot is an apparently human automation, intelligent and obedient but impersonal machine. It is relatively, that robots have started to employ a degree of Artificial Intelligence (AI) in their work and many robots required human operators, or precise guidance throughout their missions. Slowly, robots are becoming more and more autonomous.

Existing System:

The finding of cracks in railways tracks takes time consumption due to manual checking. It reduces the accuracy too. This method of design is having limited intelligence.

Proposed System:

This system involves the design of crack finding robot for finding cracks in railway tracks. This system uses controller for interfacing the robotic vehicle and crack detection sensor. The sensing device senses the voltage variations from the crack sensor and then it gives the signal to the microcontroller. The microcontroller checks the voltage variations between measured value and threshold value and controls the robot according to it.

The robotic model is interfaced with the microcontroller with the help of SPDT relays and driver IC. If any crack occurs in the rail, the robot will be stopped and then an alarm will be raised.

ARM PROCESSOR

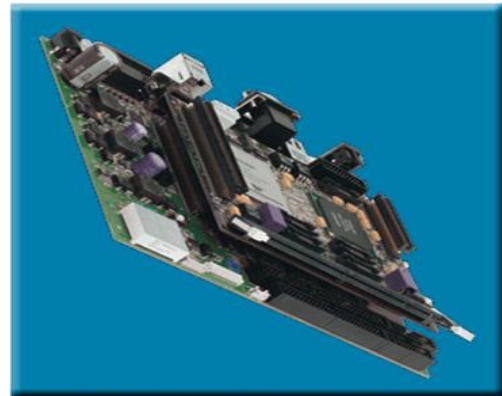

ARM7TDMI Processor Core

- Current low-end ARM core for applications like digital mobile phones
 - TDMI
 - I. T: Thumb, 16-bit compressed instruction set
 - II. D: on-chip Debug support, enabling the processor to halt in response to a debug request
 - III. M: enhanced Multiplier, yield a full 64-bit result, high performance
 - IV. I: Embedded ICE hardware
 - Von Neumann architecture
- ARM7TDMI is an advanced version of microprocessors and forms the heart of the system. This autonomous robot is used to sense the obstacle and navigate the robot in forward, backward, left, right directions.

The LPC2148 are based on a 16/32 bit ARM7TDMI-ST[™] CPU with real-time emulation and embedded trace support, together with 128/512 kilobytes of embedded high speed flash memory. A 128-bit wide memory interface and unique accelerator architecture enable 32-bit code execution at maximum clock rate. For critical code size applications, the alternative 16-bit Thumb Mode reduces code by more than 30% with minimal performance penalty. With their compact 64 pin package, low power consumption, various 32-bit timers, 4- channel 10-bit ADC, USB PORT, PWM channels and 46 GPIO lines with up to 9 external interrupt pins these microcontrollers are particularly suitable for industrial control, medical systems, access control and point-of-sale. With a wide range of serial communications interfaces, they are also very well suited for communication gateways, protocol converters and embedded soft modems as well as many other general-purpose applications.

This project uses 12v (Lead Acid Battery). This project uses two power supplies, one is regulated 5V for modules and other one is 3.3V for LPC2148. 7805 three terminal voltage regulator is used for voltage regulation. Bridge type full wave rectifier is used to rectify the ac output of secondary of 230/12V step down transformer.

Block Diagram: Receiver Unit

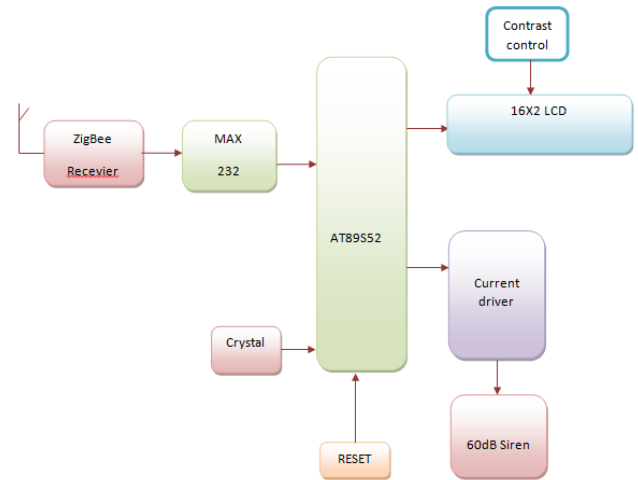

ZIGBEE TECHNOLOGY



ZigBee module:

The €1 coin, shown for size reference, is about 23 mm (0.9 inch) in diameter. ZigBee is a specification for a suite of high level communication protocols using small, low-power digital radios based on the IEEE 802.15.4-2003 standard for wireless personal area networks (WPANs), such as wireless headphones connecting with cell phones via short-range radio. The technology defined by the ZigBee specification is intended to be simpler and less expensive than other

Block Diagram:

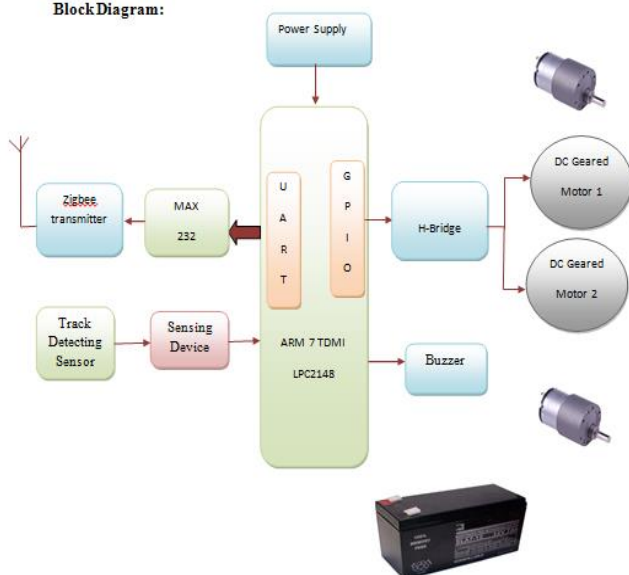

WPANs, such as Bluetooth. ZigBee is targeted at radio-frequency (RF) applications that require a low data rate, long battery life, and secure networking. The ZigBee Alliance is a group of companies that maintain and publish the ZigBee standard.

ARCHITECTURE:

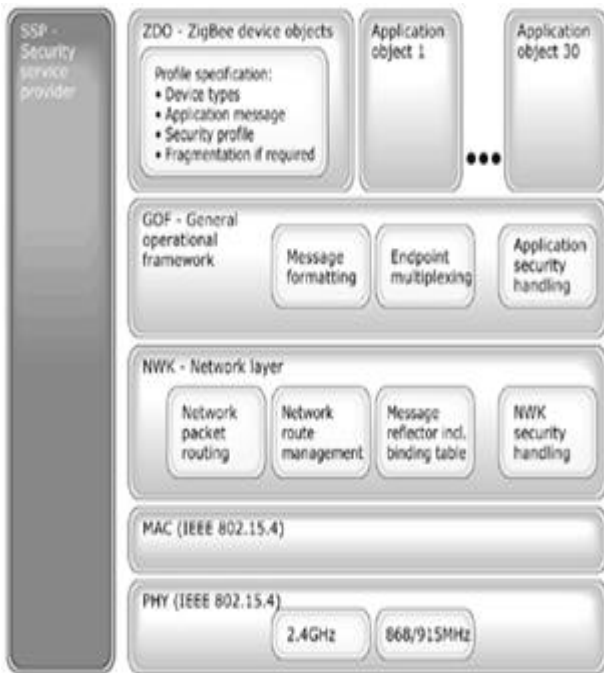

ZigBee is a home-area network designed specifically to replace the proliferation of individual remote controls. ZigBee was created to satisfy the market's need for a cost-effective, standards-based wireless network that supports low data rates, low power consumption, security, and reliability.

It may be helpful to think of IEEE 802.15.4 as the physical radio and ZigBee as the logical network and application software. Following the standard Open Systems Interconnection (OSI) reference model, ZigBee's protocol stack is structured in layers. The first two layers, physical (PHY) and media access (MAC), are defined by the IEEE 802.15.4 standard. The layers above them are defined by the ZigBee Alliance. The IEEE working group passed the first draft of PHY and MAC in 2003.



Applications of Zigbee

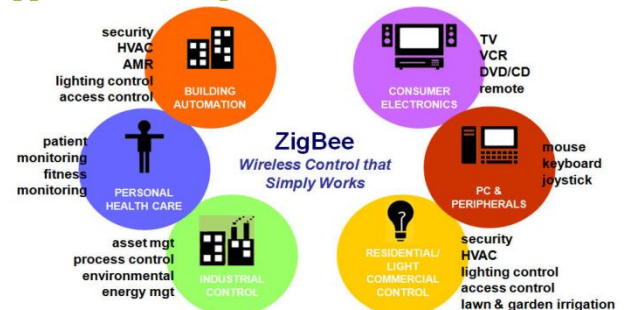

IR Transmitter, Receiver

WHAT IS INFRARED?

Infrared is a energy radiation with a frequency below our eyes sensitivity, so we cannot see it

Even that we cannot "see" sound frequencies, we know that it exist, we can listen them.



Even that we cannot see or hear infrared, we can feel it at our skin temperature sensors.

When you approach your hand to fire or warm element, you will "feel" the heat, but you can't see it. You can see the fire because it emits other types of radiation, visible to your eyes, but it also emits lots of infrared that you can only feel in your skin.

INFRARED IN ELECTRONICS

Infra-Red is interesting, because it is easily generated and doesn't suffer electromagnetic interference, so it is nicely used to communication and control, but it is not perfect, some other light emissions could contain infrared as well, and that can interfere in this communication. The sun is an example, since it emits a wide spectrum or radiation.



The adventure of using lots of infra-red in TV/VCR remote controls and other applications, brought infra-red diodes (emitter and receivers) at very low cost at the market.

From now on you should think as infrared as just a "red" light. This light can mean something to the receiver, the "on or off" radiation can transmit different meanings. Lots of things can generate infrared, anything that radiate heat do it, including our body, lamps, stove, oven, friction your hands together, even the hot water at the faucet.

To allow a good communication using infra-red, and avoid those "fake" signals, it is imperative to use a "key" that can tell the receiver what is the real data transmitted and what is fake. As an analogy, looking eye naked to the night sky you can see hundreds of stars, but you can spot easily a far away airplane just by its flashing strobe light. That strobe light is the "key", the "coding" element that alerts us.

Similar to the airplane at the night sky, our TV room may have hundreds of tiny IR sources, our body and the lamps around, even the hot cup of tea. A way to avoid all those other sources, is generating a key, like the flashing airplane. So, remote controls use to pulse rate its infrared in a certain frequency. The IR receiver module at the TV, VCR or stereo "tunes" to this certain frequency and ignores all other IR received. The best frequency for the job is between 30 and 60 KHz, the most used is around 36 KHz

Working procedure of this project:

- Our transmitter part (robot) will be moving on the track.
- For the controller at that side we have interfaced a sensing device to detect any crack in the track.
- Here the sensing device is IR sensor which follows line of sight.
- When that is missing it gives indication to the controller about the faulty track.
- So that the controller sends the same information to the remote station through zigbee.
- To come and take necessary action.

Hardware Used:

- Microcontroller unit
- Crack detection sensor
- Interfacing unit
- Robot Mechanism

Software Used:

- Keil Compiler
- Embedded C

Advantages:

- It reduces the man power
- Crack detecting efficiency is high.
- Accuracy is high.

Applications:

- Can be used for Railway Department.

References

- [1] V.Reddy, "Deployment of an integrated model for assessment of operational risk in railway track", Master Thesis, Queensland University of Technology School of Engineering Systems, 2007.
- [2] C. Esveld, "Modern railway Track". Second Edition, MRT Productions. 2001
- [3] D.Hesse "Rail inspection using ultrasonic surface waves" Thesis ,Imperial College of London,2007
- [4] C. Campos-Castellanos, Y.Gharaibeh, P. Mudge *, V. Kappatos, "The application of long range ultrasonic testing (LRUT) For examination of hard to access areas on railway tracks". IEEE Railway Condition Monitoring and NonDestructive Testing (RCM 2011) Nov 2011.
- [5] M. Singh, S.Singh1,J.Jaiswal, J. Hempshall "Autonomus rail track inspection using vision based system" .IEEE International Conference on Computational Intelligence for Homeland Security and Personal Safety .October 2006. pp 56-59
- [6] S.Zheng, X.An, X.Chai, L. Li "Railway track gauge inspection method based on computer vision" IEEE International Conference on Mechatronics and Automation, 2012. pp 1292-1296
- [7] W. Al-Nuaimy , A. Eriksen and J. Gasgoyne " Train-mounted gpr for high-speed rail trackbed inspection" Tenth International Conference on Ground Penetrating Radal; 21 -24 June, 2004
- [8] A.Vanimiredd, D.A.Kumari "Automatic broken track detection using LED-LDR assembly" International Journal of Engineering Trends and Technology (IJETT) - Volume4 Issue7- July 2013
- [9] Hayre, Harbhajan S., "Automatic Railroad Track Inspection," Industry Applications, IEEE Transactions on , vol.IA-10, no.3, pp.380,384, May 1974
- [10] Z. Sam Daliri1, S. Shamshirband , M.A. Besheli " Railway security through the use of wireless sensor networks based on fuzzy logic". International Journal of the Physical Sciences Vol. 6(3), pp. 448-458, 4 February, 2011
- [11] S. Ramesh, S. Gobinathan "Railway faults tolerance techniques using wireless sensor networks". IJECT Vol. 3, Issue 1, Jan. - March 2012.
- [12] A. Z Lorestani ,S. A Mousavi, R. Ebadaty, "Monitoring RailTraffic Using Wireless Sensor Network September-2011.