

Harmful Gases Wireless Network Monitoring System Design Using Zigbee, GSM Technology

Maaturi Rakesh

M.Tech (ES),

Raja Mahendra College of Engineering, Hyderabad.

B.Gajan, M.Tech

Assistant Professor,

Raja Mahendra College Of Engineering, Hyderabad.

ABSTRACT:

An odor is composed of molecules, each of which has a specific size and shape. Each of these molecules has a correspondingly sized and shaped receptor in the human nose. When a specific receptor receives a molecule, it sends a signal to the brain and the brain identifies the smell associated with that particular molecule. Electronic noses based on the biological model work in a similar manner, albeit substituting sensors for the receptors, and transmitting the signal to a control circuit, rather than to the brain. Electronic noses are one example of a growing research area called biometrics, or which involves human-made applications patterned on natural phenomena. This project uses two sensors like carbon monoxide sensor and LPG gas sensors. These sensors are mounted on a PCB and visual indicator with audible buzzer is provided for alert signal. When the sensor is activated it sends the signal to receiver section using zigbee and sends the sms using GSM modem. This project is much useful for mines detection and surveillance applications.

I.Introduction:

The increase in the development of technology and the human race, we failed to take care about the surroundings in which we live in. Thus we polluted the environment and thereby reducing the quality of the place we live. Electronic noses were originally used for quality control applications in the food, beverage and cosmetics industries. Current applications include detection of odors specific to diseases for medical diagnosis, and detection of pollutants and gas leaks for environmental. The LPC2148 are based on a 16/32 bit ARM7TDMI-S™ CPU with real-time emulation and embedded trace support, together with 128/512 kilobytes of embedded high speed flash memory. A 128-bit wide memory interface and unique accelerator architecture enable 32-bit code execution at maximum clock rate. For critical code size applications, the alternative 16-bit Thumb Mode reduces code by more than 30% with minimal performance penalty.

With their compact 64 pin package, low power consumption, various 32-bit timers, 4- channel 10-bit ADC, USB PORT, PWM channels and 46 GPIO lines with up to 9 external interrupt pins these microcontrollers are particularly suitable for industrial control, medical systems, access control and point-of-sale. With a wide range of serial communications interfaces, they are also very well suited for communication gateways, protocol converters and embedded soft modems as well as many other general-purpose applications.

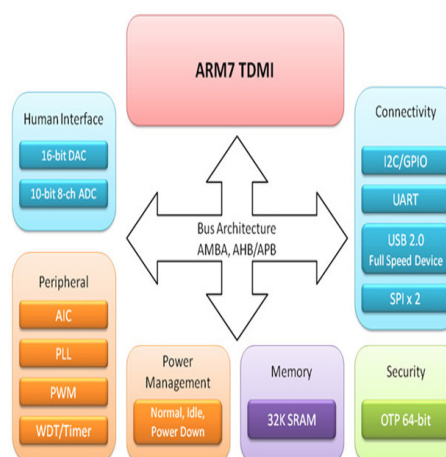

ARM PROCESSOR:

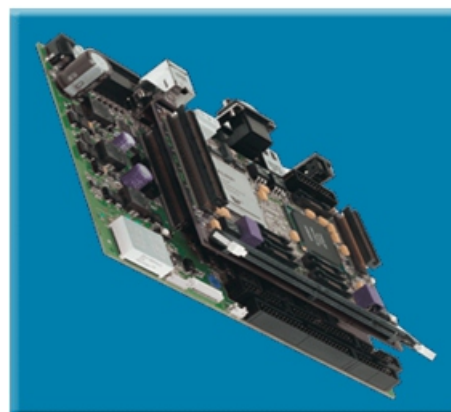

ARM7TDMI Processor Core

- Current low-end ARM core for applications like digital mobile phones

•TDMI

- oT: Thumb, 16-bit compressed instruction set
- oD: on-chip Debug support, enabling the processor to halt in response to a debug request
- oM: enhanced Multiplier, yield a full 64-bit result, high performance
- oI: Embedded ICE hardware
- Von Neumann architecture

Global System for Mobile Communication (GSM)

Definition:

GSM, which stands for Global System for Mobile communications, reigns (important) as the world's most widely used cell phone technology. Cell phones use a cell phone service carrier's GSM network by searching for cell phone towers in the nearby area. Global system for mobile communication (GSM) is a globally accepted standard for digital cellular communication. GSM is the name of a standardization group established in 1982 to create a common European mobile telephone standard that would formulate specifications for a pan-European mobile cellular radio system operating at 900 MHz. It is estimated that many countries outside of Europe will join the GSM partnership.

TABLE I. SOME COMMANDS USED IN GSM DATA TRANSFER MODULE OF THE SYSTEM

AT Command	Meaning
+CMGI	Module ok
+CMGS	Send message
+CMGW	Write message to memory
+CMGD	Delete message
+CMGC	Send command
+CMSS	Send message from storage

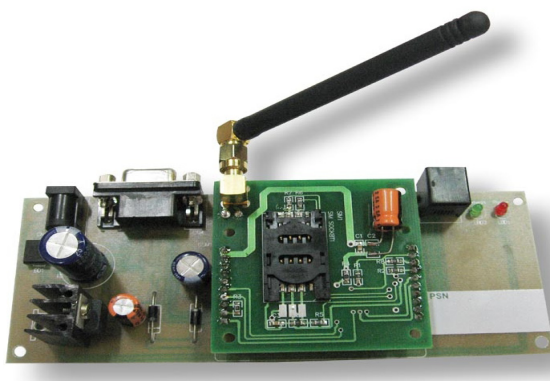

MQ-2 SMOKE SENSOR :

Sensitive material of MQ-2 smoke sensor is SnO₂, which with lower conductivity in clean air. When the target combustible smoke exist, the sensor's conductivity is higher along with the smoke concentration rising. Please use simple electro circuit, Convert change of conductivity to correspond output signal of smoke concentration. MQ-2 smoke sensor has high sensitive to LPG, Propane and Hydrogen, also could be used to Methane and other combustible steam, it is with low cost and suitable for different application.

Schematic representation of sensor:

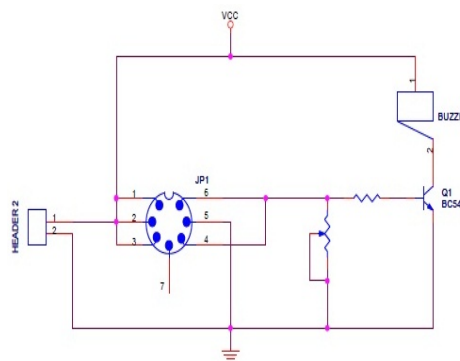

III..Block diagram

Receiver:

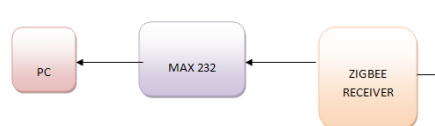

Transmitter:

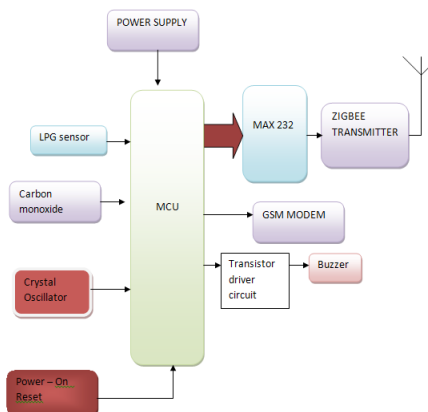

IV. Software requirements

A. Keil compiler:

Keil compiler is a software used where the machine language code is written and compiled. After compilation, the machine source code is converted into hex code which is to be dumped into the This project uses regulated 3.3V, 500mA power supply. Unregulated 12V DC is used for relay. 7805 three terminal voltage regulator is used for voltage regulation. Bridge type full wave rectifier is used to rectify the ac out put of secondary of 230/12V step down transformer. microcontroller for further processing. Keil compiler also supports C language code.

B. Proload:

Proload is a software which accepts only hex files. Once the machine code is converted into hex code, that hex code has to be dumped into the microcontroller placed in the programmer kit and this is done by the Proload. Programmer kit contains a microcontroller on it other than the one which is to be programmed. This microcontroller has a program in it written in such a way that it accepts the hex file from the keil compiler and dumps this hex file into the microcontroller which is to be programmed.

V. Advantages:

- It reduces the man power
- Smoke detecting efficiency is high
- Accuracy is high

VI. Application:

- Hospitals
- Mines detection
- Industries

VII. Conclusion:

This project presents a high sensitive sensor based SMS alert. Experimental work has been carried out carefully. The proposed method is verified to be highly beneficial for haze monitoring.

VIII. REFERENCES:

- [1] K. A Othman, N Li, E. H Abdullah, N Hamzah, "Haze Monitoring System in City of Kuala Lumpur using Zig-bee Wireless Technology Implementation", WCE 2013
- [2] V. N. Bashkin (2003). "Environmental Chemistry: Asian Lessons", pp 115-116
- [3] Diamond. D, Coyle. S, Scarmagnani. S, and Hayes. J (2008). "Wireless sensor networks and chemo-/biosensing". Chemical reviews, 108(2): p. 652-679
- [4] Chuanyang Xu, Zhongting Wang, Shenshen Li, Hui Chen, "A Haze Monitoring Over North China Plain", Geoscience and Remote Sensing Symposium (IGARSS), 2012
- [5] De Hui Wang, Li Hua Xia, Yao Qiu Kuang, "A Case Study on Monitoring Haze in Pearl River Delta by MODIS", The 2nd International Conference on Bioinformatics and Biomedical Engineering, 2008. ICBBE 2008.
- [6] Xingwei He, Yong Xue, Yingjie Li, Jie Guang, Ying Wang, Linlu Mei, Hui Xu " Multi-scale Aerosol Retrieval Over Land From Satellite Data And Its Application On Haze Monitoring", Geoscience and Remote Sensing Symposium (IGARSS), 2011
- [7] Tae-seok Lee, Yuan Yang, "A SMS Based Ubiquitous Home Care System", University of Korea, 2005
- [8] American Industrial Hygiene Association, Air Pollution Manual, Brawn-Brumfield, Inc., 1960, Vols, I & II.
- [9] Department of Environment "Environmental Quality Report (EQR) 2008-Pollution Sources Inventory. pdf Internet: <http://apps.doe.gov.my/portal-efiles/e-publication/view.php> May, 23, 2010