

## Artificial Neural Network Based Load Frequency Control for Steady State Load Variations

**S.Kondala Rao**

PG Scholar,  
Department of EEE,  
Sri Sivani Institute of Technology,  
Srikakulam, Andhra Pradesh, India.

**P.Chandra Mouli**

Assistant Professor,  
Department of EEE,  
Sri Sivani Institute of Technology,  
Srikakulam, Andhra Pradesh, India.

### Abstract:

Steam turbine generation units are used in the power system especially for some special features of fossil-fuelled power plants. When a load disturbance occurred in the system, a frequency variation will cause a primary regulation action on generation units. The units will automatically adjust their outputs to fit for the new load demand. Variation of the governing valve position may exceed to the outlet pressure of the related boiler but boiler often has a long control time cycle after the pressure error was observed. Fuzzy controller is usually used to speed up the regulation procedure of boiler and to improve the stability of the steam parameters upstream of steam turbine. Model parameter identification is one of the most reliable tools to estimate the model parameters. In the proposed work, a general model of power plant with Fuzzy & Neural Network control system is built for power system dynamic analysis. The model responses will be compared with fuzzy & Neural Network for system frequency stability.

### Index Terms:

Fuzzy controller, Neural Networks, dynamic model, Parameter identification, power plant.

### 1.INTRODUCTION:

Steam turbine generation units are used in the power system for some special features of fossil-fuelled power plants. When a load disturbance occurred in the system, frequency variation will cause a primary regulation action on generation units. The units will automatically adjust their outputs to fit for the new load demand. Variation of the governing valve position may exceed to the outlet pressure of the related boiler but boiler often has a long control time cycle after the pressure error was observed.

Fuzzy controller is usually used to speed up the regulation procedure of boiler and to improve the stability of the steam parameters upstream of steam turbine. Many researchers have studied the mathematic models of power plant for power system dynamic analysis. According to their research, low order models for turbine units are more popular for power system dynamic analysis. According to huge test experiences, single turbine model is not without a consideration of a main stream pressure variation. Boiler model is also needed for some circumstances. Control System of boiler and the Fuzzy controller acting on both the boiler and turbine systems will have great impact on the pressure stability even output power of turbine units. But these control systems are not well considered in relative research. In this paper, a fossil-fuel power plant model is presented with Fuzzy controller power system analysis. The model parameters are identified for a turbine coal fired generation unit. The model responses are compared to the model. Frequency response models have received limited treatment in the literature. The basic concept of the model derived here is based on the idea of uniform or average frequency, where synchronizing oscillations between generators are filtered out, but the average frequency behaviour is retained. The synchronizing oscillations are, taken from the simulations of reference [1]. We seek to average these individual machine responses with a smooth curve that can be used to represent the average frequency for the system. Such a filtered or average frequency.. Similar and related approaches have been pursued more recently [3, 4] through work on energy functions. The basic ideas are also important in the work on system Area control simulators [5, 6], as well as the work on long term dynamics [7, 8]. In addition to these resources, certain ideas have also been adopted from the work on coherency based dynamic equivalents [9, 10], as well as the work on transient energy stability analysis. A Genetic Algorithm (GA) represents a heuristic search technique based on the evolutionary ideas of natural selection and genetics.

Although randomized, using the historical information they direct the search into the region of better performance within the search space. In this paper, the fuzzy and ANN controller is developed and compared with respect to their overshoot or undershoot and settling time under various operating conditions for a two area steam turbine and boiler model.

## 2.MODELING OF STEAM TURBINE:

In a steam turbine the stored energy of high temperature and high pressure steam is converted into mechanical (rotating) energy, which then is converted into electrical energy in the generator. The original source of heat can be a furnace fired by fossil fuel (coal, gas, or oil) or biomass. The turbine can be either tandem compound or cross compound. In a tandem compound unit all sections are on the same shaft with a single generator, while a cross compound unit consists of two shafts each connected to a generator. The cross compound unit is operated as one unit with one set of controls. The power output from the turbine is controlled through the position of the control valves, which control the flow of steam to the turbines.

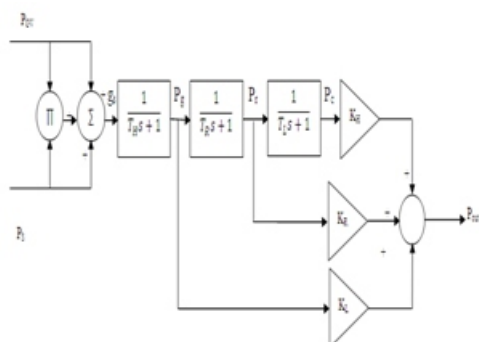

Fig.1 steam turbine model.

The valve position is influenced by the output signal of the turbine controller. High Pressure (HP), Intermediate Pressure (IP) and Low Pressure (LP) are the different turbine sections. The turbine considered for study in this paper is reheating type. Reheating improves efficiency [8]. The effects of steam chest; reheated and nonlinear characteristics of control valve are considered. The fraction of turbine power generated by intermediate section is assumed as negligible on base value. Steam flow entered into steam turbine  $g_s$  is proportional to sum of the product of governing valve position variation  $PGV$  and steam pressure variation of superheater  $P_s$  and two variations themselves.

TH, TR and TL are time constants of three equivalent steam volume as high pressure volume, reheated volume and crossover volume, and  $P_g$ ,  $P_r$  and  $P_c$  are average steam pressures of three volumes. Output power is a sum of output by three kinds of turbine cylinder. Power of each cylinder is considered to be proportion to its inlet steam pressure due to high pressure ratio. Relative with the rated output power the output portions of three cylinders are KH, KR and KL respectively.

## 3.FUZZY LOGIC CONTROLLER:

Although it is possible to design a fuzzy logic type of controller by a simple modification of the conventional ones, via inserting some meaningful fuzzy logic IF- THEN rules into the control system, these approaches in general complicate the overall design and do not come up with new fuzzy controllers that capture the essential characteristics and nature of the conventional controllers. Besides, they generally do not have analytic formulas to use for control specification and stability analysis. The fuzzy controllers to be introduced below are natural extensions of their conventional versions, which preserve the linear structures. Instead of summation effect a mamdani based fuzzy inference system is implemented. The inputs to the mamdani based fuzzy inference system are error and change in error. The main difference is that these fuzzy controllers are designed by employing fuzzy logic control principles and techniques, to obtain new controllers that possess analytical formulas very similar to the conventional digital controllers.

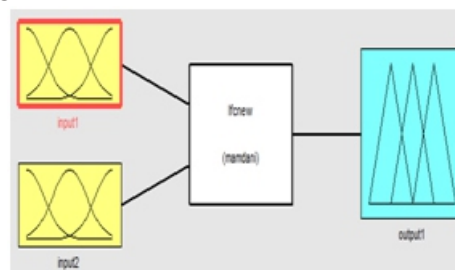

Fig.2 Fuzzy Inference System Editor Fuzzy Controller.

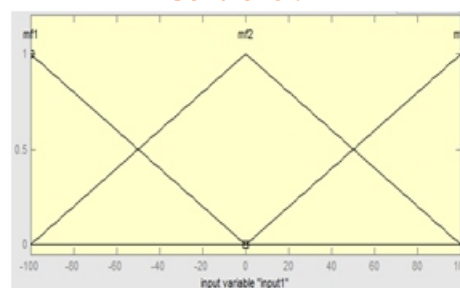

Fig.3 Fuzzy Controller output1

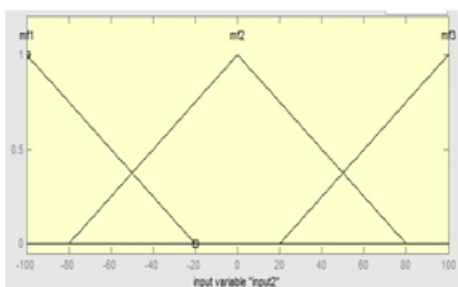

Fig.4 Fuzzy Controller input2

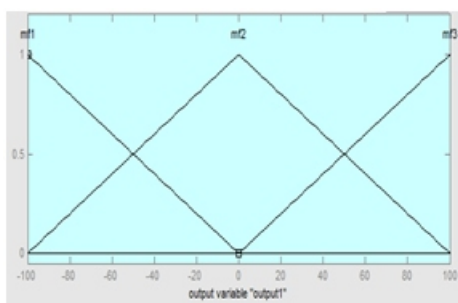

Fig.5 Fuzzy Controller output

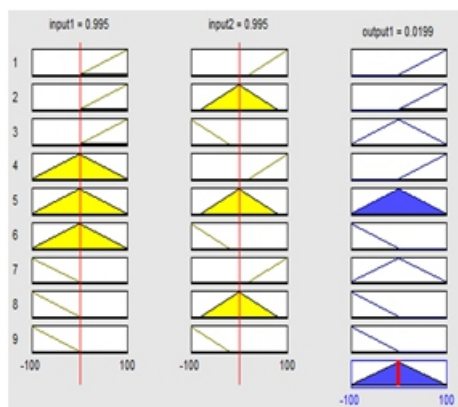

Fig.6 Fuzzy Controller Rule View

#### 4.ARTIFICIAL NEURAL NETWORKS:

Numerous advances have been made in developing intelligent systems, some inspired by biological neural networks]. Researchers from many scientific disciplines are designing artificial neural networks to solve a variety of problems in pattern recognition, prediction, optimization, associative memory, and control. Conventional approaches have been proposed for solving these problems. Although successful applications can be found in certain well-constrained environments, none is flexible enough to perform well outside its domain. ANNs provide exciting alternatives, and many applications could benefit from using them.

This article is for those readers with little or no knowledge of ANNs to help them understand the other articles in this issue of Computer. The long course of evolution has given the human brain many desirable characteristics not present in von Neumann or modern parallel computers. These include massive parallelism, distributed representation and computation, learning ability, Generalization ability.

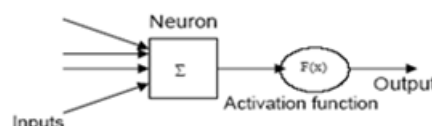

Fig.7 Simple Artificial Neuron

#### 5.TWO AREA STEAM TURBINE MODEL SIMULATIONS RESULTS:

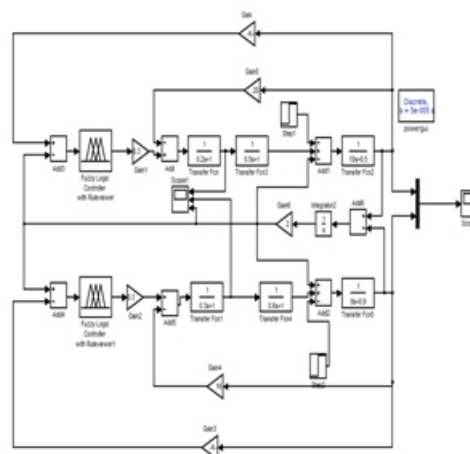

Fig.8 Two Area system with Fuzzy controller

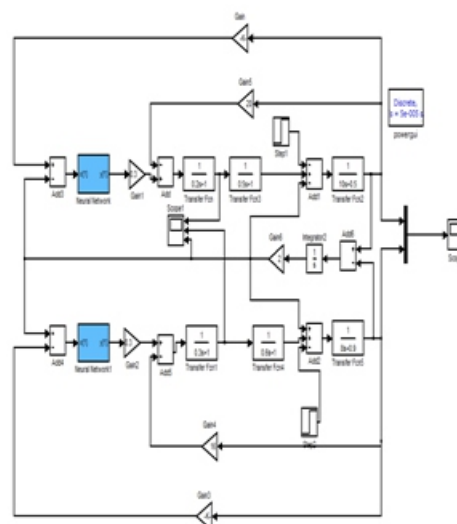

Fig.9 Two Area system with Neural Networks

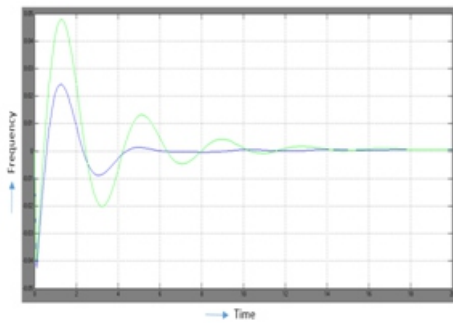

Fig.10 Frequency response with Fuzzy controller

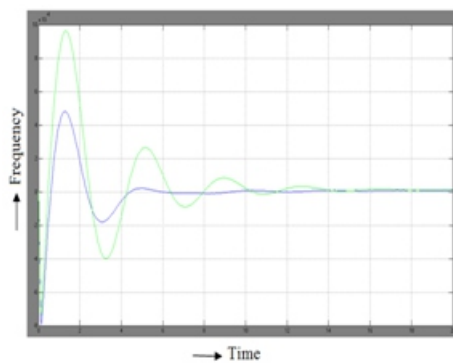

Fig.11 Frequency response with Neural Networks.

In the above graphs firstly, a step load disturbance occurs in two areas (area1&area2) with step load increasing of 0.03p.u. With the use of a PID controller with a step load disturbance of 0.03p.u rise time has been reduced to 0.32s, settling time to 9.97 and overshoot is reduced to 137. With the use of a fuzzy PID controller with a step load disturbance of 0.03p.u rise time has been reduced to 0.3s, settling time to 9.97 and overshoot is reduced to 125.2.

### 5.1.Steam turbine model:

The steam turbine is mostly large power reheat units. There are multi low pressure cylinders and even multi intermediate pressure cylinders. The intermediate pressure cylinders can be considered as for the dynamic analysis.

TH High pressure temperature

TR Reheat temperature

TL Lower pressure temperature

Table 2: Time constant value for turbine model:

$T_H$	0.26s
$T_R$	18.5s
$T_L$	0.69s

### 6.CONCLUSIONS:

For supplying stable and reliable electric power, load frequency control is an important issue in power system operation and control. Automatic load frequency control is used to maintain the generator power output and frequency within the prescribed values. In this work the two area load frequency controller is considered. The simulated study shows the frequency response and steady state response of two area systems by using fuzzy and Neural Networks. The fuzzy controller is compared with Neural Networks. The simulation study shows that the stability of the system improved the frequency response and less settling time and steady state responses. Hence from the results we conclude that the Neural Networks is said to be better compensating then fuzzy controller.

### REFERENCES:

- 1.Power system Stability and Control by Prabhakundur.
- 2.Power System Engineering byNagrath Kothari
- 3.IEEE Committee Report, “Dynamic Models for Steam and Hydro Turbines in Power System Studies”, IEEE Trans Power Apparatus & Systems, Vol. 92, No. 6, 1973, pp. 1904- 1915.
- 4.L. N. Bize, J. D. Hurley, “Frequency Control Considerations for Modem Steam and Combustion Turbines”, IEEE Engineering Society Winter Meeting, 1999, pp. 548-553.
- 5.Dai Yipping, Zhao Ting, TianYunfeng, Gao Lin, “Research on the influence of primary frequency control distribution on power system security and stability”, Second IEEE Conference on Industrial Electronics and Applications, 2007, pp.222-226.
- 6.P. M. Anderson, M. Mirheydar, “A low-order system frequency response model”, IEEE Transaction on Power Systems, Vol. 5, No. 3, 1990, pp. 720-729.
- 7.K. J. Astrom, K.Eklund, “A simplified non-linear model of a drum boiler-turbine unit”, International Journal of Control, Vol. 16, No. I, 1972,pp. 145-169.
- 8.de Mello, F.P., “Dynamic models for fossil fuelled steam units in power system studies”, IEEE Transactions on Power Systems, Vol. 6, No. 2,1991, pp. 753-761.

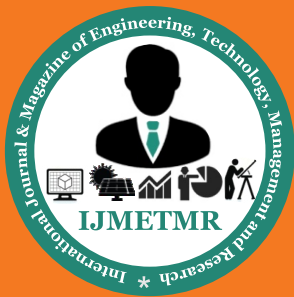

9. Dai Yipping, Zhao Ting, Tian Yunfeng, Gao Lin, "Research on the primary frequency control characteristics of generators in power system", Second IEEE Conference on Industrial Electronics and Applications, 2007, pp. 569-574.

10. QH WU, "Learning coordinated control of power systems using interconnected learning automata", Electrical power & Energy systems, Vol. 17, No. 3, 1995, pp. 91-99.

11. Gao Lin, Dai Vi-ping, Xia Jun-rong, "A New Framework for Power System Identification Based on an Improved Genetic Algorithm", 2009 4th IEEE Conference on Industrial Electronics and Applications, May 25-27, 2009, Xi'an, China.

12. Gao Lin, Dai Vi-ping, Xia Jun-rong, "Parameter Identification of Hydro Generation System with Fluid Transients Based on Improved Genetic Algorithm", 2009 Fifth International Conference on Natural Computation, 14-16 August 2009, Tianjin, China.

13. H.R. Berenji, Fuzzy logic controllers, in: R.R. Yager, L.A. Zadeh (Eds.), An Introduction to Fuzzy Logic Application in Intelligent System, Kluwer Academic Publisher, Boston, MA, 1992.

14. W.R. Hwang and S. Zein Sabatto. "Fuzzy Controller Design Using Genetic Algorithm" in Engineering new century, Proceeding, IEEE, April 1997.