

A Novel Method of 60 GHz AGILE EBG Based ANTEENA with Space Communication

Elpula Srikala

PG Scholar

Department of ECE

KLR College of

Engineering & Technology, Engineering & Technology, Engineering & Technology,
 Telangana.

Y.Nirmala

Assistant Professor

Department of ECE

KLR College of

Telangana.

M.Pavani

HoD

Department of ECE

KLR College of

Telangana.

M.Surendra Kumar

Principal

KLR College of

Engineering & Technology,

Telangana.

Abstract:

A new meta material-inspired polarization recongrurable micro strip antenna is presented in this paper, in which a square slot is etched on the ground plane, and two PIN diodes are mounted across the slot for polarization recongrurability. A complementary split ring resonator (CSRR) can be formed by integrating the square slot with two diodes. By controlling the working states of two diodes, we can change the gap position of CSRR which will alter the polarization of the microstrip antenna. Therefore, the polarization of the micro strip antenna can be switched among linear polarization (LP), left-hand circular polarization (LHCP) and right-hand circular polarization (RHCP), respectively. The planar electromagnetic band gap (EBG) structure is further introduced to extend the bandwidth of the 3 dB axial ratio. In addition, the proposed meta material-inspired antenna with agile polarization recongruration can be feasibly controlled by using a simple biasing circuit. The simulations and experiments are given to verify the electiveness and correctness of the proposed recongrurable antenna design.

INTRODUCTION

Polarization recongrurable antennas have a wide application for next generation wireless communication systems. The circular polarization (CP) antennas have the features of multipath effects reduction and flexibility in the orientation angle between the transmitter and receiver, which have been widely used in wireless and satellite communication systems [1-3]. A CP wave can be generated by exciting two linear polarization (LP)

modes with equivalent amplitude and 90° phase deference. Meta materials are a kind of new artificial materials or structures, which provide a new means for controlling the transmission of electromagnetic waves. Meta material structures are widely used to design new antennas and microwave devices which are also viewed as meta material-inspired or meta material-based antennas and devices [4-7]. Complementary split ring resonator (CSRR) is one of the meta material structures, which has been applied for the design of circularly polarized antenna [6]. The band gap characteristics of EBG structures have been used to improve the axial ratio bandwidth and impedance matching of antennas [7]. Meanwhile, with the development of wireless communication technologies, some multifunctional terminals with recongrurable antennas are proposed to satisfy the requirements [8, 9]. Polarization recongrurable antennas attract considerable attention and various types have been reported. In [10], four L-shaped slots are etched and eight PIN diodes are placed in the ground, but the antenna can be switched only between the right-handed and left-handed CPs. Two square loops are etched and two PIN diodes are placed in the antenna for switching between CP and LP in [11], and two DC bias circuits are needed to control two diodes separately. In this paper, we present a new design of polarization recongrurable antenna which is composed of a rectangle patch and a ground plane etched with a square slot and EBG structures. Two PIN diodes are mounted on the square slot to change it into CSRR with gap in different positions, which will allow the antenna to switch between linear and circular polarizations by controlling single DC voltage. As the

PIN diodes are placed in the ground plane and the DC biasing circuit is isolated, the influence of the diodes on the antenna is small. By integrating with meta material structures, the antenna can achieve a circular polarization at 3.53 GHz with 3 dB axial ratio bandwidth of 60 MHz, which is about 60% wider than conventional CP antenna. Meanwhile, the measured radiation patterns show low cross polarization. The comparison of the simulated and the measured results shows a good agreement.

POLARIZATION RECONFIGURABLE ANTENNA DESIGNS

In this paper, a metamaterial-inspired polarization reconfigurable antenna is introduced, the geometry of the antenna is shown in Fig. 1. The microstrip antenna is designed on a dielectric substrate with relative permittivity of 2.65 and a loss tangent of 0.0012. The thickness of the substrate is 1 mm. A rectangle patch is printed on one side of the substrate, and a square slot is etched in the metallic ground plane on the other side. Meanwhile, the periodic metal patch EBG structure is loaded on the same side of the ground. Two PIN diodes are mounted across the square slot, as shown in Fig. 1(c), to switch the polarization of the antenna among linear polarization, left-hand and right-hand circular polarizations by changing the working state of the two diodes. The antenna is designed to work at 3.5 GHz (WiMax band). Here a metamaterial-inspired right-hand circularly polarized antenna is firstly designed, which is also a basis of the proposed polarization reconfigurable antenna. The simulation was done by using Ansys HFSS (Ver. 13) based on finite-element full-wave analysis [12].

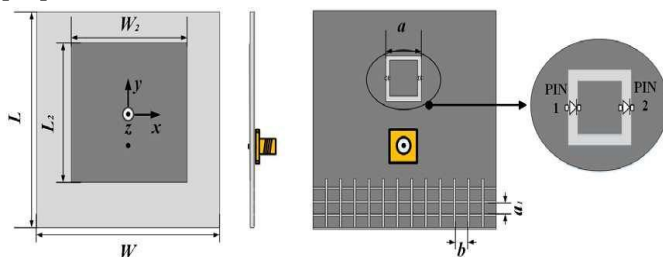

Figure 1. Geometry of polarization reconfigurable antenna. (a) Top view, (b) side view, and (c) bottom view.

Metamaterial-inspired Circularly Polarized Antenna

The geometry of the proposed CP antenna is shown in Fig. 2, and its dimensions are listed in Table 1. The overall size of the substrate is $L \times W \times 1$ mm. The top of the substrate is a rectangle patch with a size of $L_2 \times W_2$, and the bottom of the substrate is a metallic ground embedded with a CSRR and periodic EBG patch structures. The side length of the CSRR is a while the width of the gap is g , and the EBG structure is composed of periodic $a_1 \times b$ metallic patches.

Table 1. Dimensions of the proposed CP antenna.

Parameters	L	L_2	W	W_2	a	g	S	a_1	b
Value (mm)	40	22.9	40	24.2	5.9	0.5	3.8	1.5	2

It is worth pointing out that a CSRR is etched on the ground plane offset from the center with distance of S along the y -axis, and O_1 is the center point of the CSRR. In this case, the proposed microstrip antenna will radiate a CP wave as the gap orientation asymmetric to the current propagating direction. The geometric parameters of the CSRR are also shown in Table 1.

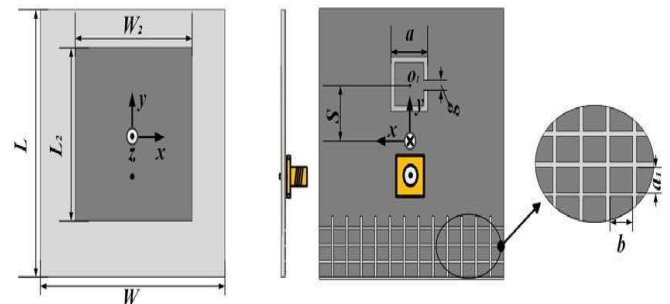

Figure 2. Geometry of the proposed circularly polarized antenna, (a) top view, (b) side view, and (c) bottom view.

The resonant frequency of the conventional microstrip antenna without CSRR and EBG is 3.64 GHz, and that of the proposed CP antenna with CSRR but without EBG structure is about 3.5 GHz, as shown in Fig. 3. The planar EBG structure introduced to replace part of the metal ground can improve the 3 dB axial ratio (AR) bandwidth of the CP radiation, which can be extended from 30 MHz to 50 MHz while the impedance

bandwidth keeps the same. The simulated radiation efficiency of both CP antennas are above 90% as shown in Fig. 4. Fig. 5 shows the time varying current distribution plots of the proposed antenna at 3.5 GHz, where T is the time period. It can be seen from the current flow directions that the antenna radiates a RHCP wave.

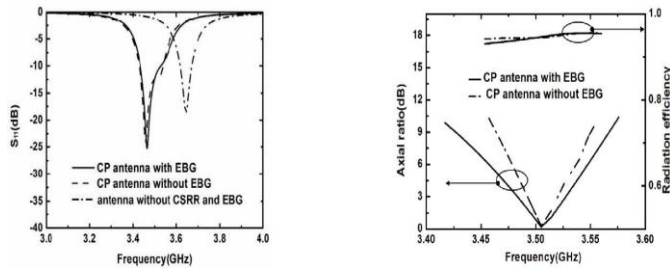

Figure 3. Comparison of S_{11} among the conventional microstrip antenna, the proposed CP antenna with and without EBG structure

Figure 4. Comparison of axial ratio and radiation efficiency between antennas with and without EBG structure.

The effect of CSRR parameters on antenna performance is investigated. Figs. 6 and 7 show S_{11} and AR curves of the proposed CP antenna with different values of a and g . Note that when the value of a parameter was changed, such as when the side length a of CSRR was changed from 5.7 mm to 6.1 mm, the values of the other parameters were kept the same as in Table. When the value of a is increased, the working frequency band of the antenna will shift toward low frequency. In this design, a is chosen to be 5.9 mm for lowest AR value and better impedance matching at 3.5 GHz. Meanwhile, by varying the width of the gap of CSRR (g), S_{11} and axial ratio of the antenna are almost unchanged. Because g is not sensitive to the antenna performance, the gap of the CSRR can be replaced by PIN diode which can control the polarizations of the antenna among the LHCP, RHCP and LP.

Polarization Reconfigurable Patch Antenna

As shown in Fig. 2, the CSRR structure etched on the ground plane can produce the CP radiation from the microstrip antenna. When the gap of the CSRR is oriented in y direction, the antenna is a RHCP antenna.

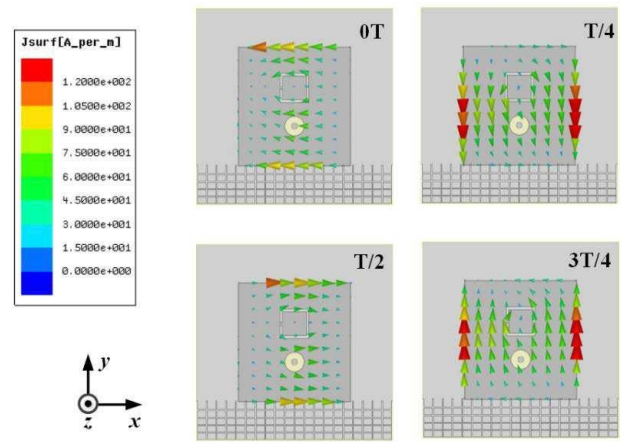

Figure 5. Antenna time-varying current distribution at different time, (a) $t = 0$, (b) $t = T/4$, (c) $t = T/2$, and (d) $t = 3T/4$.

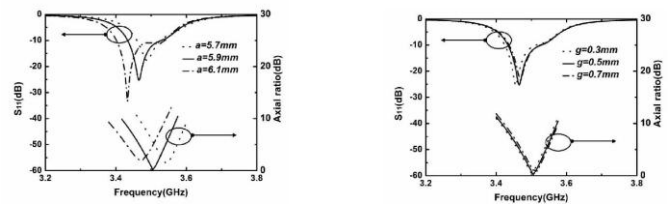

Figure 6. Effect of variation of a on the S_{11} and AR performance.

Figure 7. Effect of variation of g on the S_{11} and AR performance.

However, if the gap is imaged symmetrically around y axis, i.e., oriented in $+x$ direction, the antenna will become a LHCP antenna. Because the position of the gap of the CSRR is symmetrical along the yo z -plane and other parameters remain the same, the RHCP and LHCP should have similar features including axial ratio bandwidth and S -parameter. Meanwhile, the parameter study of a in last section shows that the dimension of the gap only influences the CP properties slightly, therefore two PIN diodes are implemented further to control the position of the gap of CSRR, which will determine the polarization of the antenna. The orientation of the two PIN diodes is illustrated in Fig. 1(c) clearly, and the gap is narrowed where the diodes are mounted. The ground is separated into two portions and the DC bias voltage across two portions can be supplied directly. Note that the reversed DC voltage polarities are applied to PIN1

and PIN2. Table 2 lists available working configurations of the two PIN diodes. Considering the introduction of the PIN diodes, the dimensions of the antenna are optimized, as shown in Table 3.

Table 2. Working configuration of two pin diodes.

State	PIN1	PIN2	Polarization
State 1	ON	OFF	LHCP
State 2	OFF	ON	RHCP
State 3	OFF	OFF	LP

Table 3. Dimensions of the proposed P antenna.

Parameters	L	$L2$	W	$W2$	a	S	$a1$	b
Value (mm)	40	22.9	40	24.5	5.5	4.6	1.5	2

In this design, PIN diodes of SMP1345-079LF are used as switches. The diode is equivalent to a 1.5 Ω -resistor at the "ON" state, and the RF current can flow across the slot through the diode, while a 0.15-pF capacitor at the "OFF" state and the RF current is blocked by the diode. In addition, when the PIN 1 is ON and the PIN 2 is OFF, the gap of the CSRR is oriented in the +x direction, and the antenna radiates LHCP wave. On the contrary, when the PIN1 is OFF and the PIN 2 is ON, the gap of the CSRR is oriented in the -x direction, RHCP can be achieved. When both of the diodes are OFF, it enables the antenna to radiate LP wave. In conclusion, by controlling single DC voltage, the antenna polarization can be switched among LHCP, RHCP and LP, respectively.

SIMULATION AND MEASUREMENT RESULTS

According to the design dimensions given above, the polarization reconfigurable patch antenna was fabricated as shown in Fig. 8. Two PIN diodes of SMP1345-079LF are placed across the square slot. The slot separates the ground into two parts, and each part is connected with one wire. The bias voltage is applied through the two

wires, and reversed DC voltage polarities are applied to PIN 1 and PIN 2. The antenna was measured with a network analyzer 8719ES and in the anechoic chamber by using the near-field measurement system. The measured S_{11} of the proposed antenna which works in different configurations in Table 2 are shown in Figs. 9(a), 10(a) and 11, respectively. It can be seen that the measured results are in good agreement with simulated results. A small frequency shift is mainly due to the dielectric substrate and the influence of the PIN diodes. The impedance bandwidth of LHCP is about 120 MHz (3.47 GHz{3.59 GHz), and that of RHCP is about 110 MHz (3.48 GHz{3.59 GHz), while the impedance bandwidth of LP is 70 MHz (3.52 GHz{3.59 GHz).

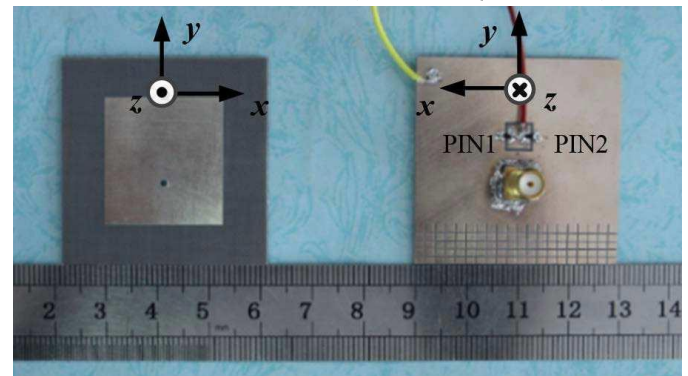

Figure 8. Photograph of the fabricated reconfigurable antenna.

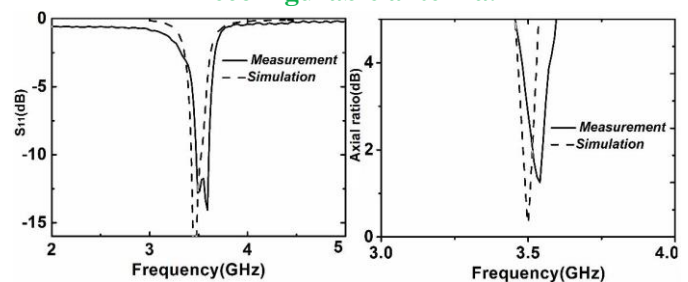

Figure 9. Simulated and measured results of (a) S_{11} and (b) axial ratio of LHCP.

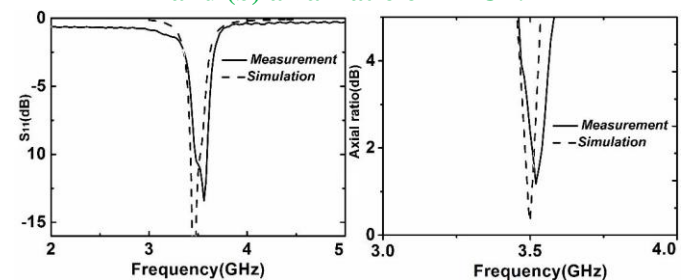

Figure 10. Simulated and measured results of (a) S_{11} and (b) axial ratio of RHCP

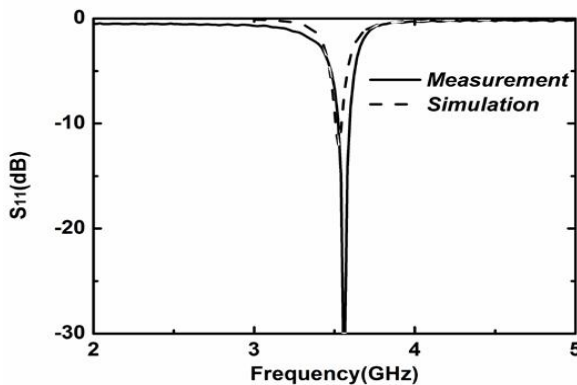

Figure 11. Simulated and measured S_{11} for the linear polarization mode of the antenna.

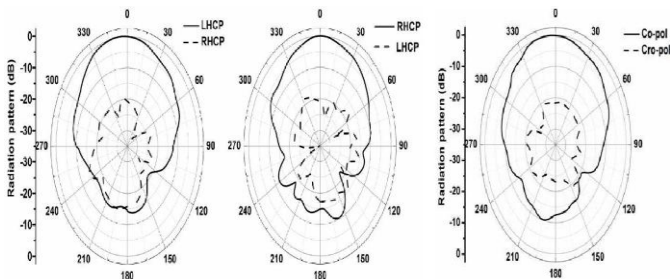

Figure 12. Measured radiation patterns of the proposed reconfigurable antenna. (a) LHCP, (b) RHCP, and (c) LP.

Additionally, the measured 3 dB AR-bandwidth of LHCP and RHCP are about 60 MHz and plotted in Fig. 9(b) and Fig. 10(b), respectively, which also show good agreement with simulated results.

The radiation patterns of the two CP cases and LP case in the xoz plane at 3.53 GHz are measured and the results are shown in Fig. 12, respectively. The radiation patterns of LHCP, RHCP and LP modes can be observed.

CONCLUSION

A new polarization reconfigurable microstrip patch antenna integrating with metamaterial structure is presented in this paper, which can realize the transformation among the LHCP, RHCP, and LP. The CP radiation is realized by etching a CSRR on the ground of microstrip antenna, and 60% improvement of the 3 dB axial ratio bandwidth of the antenna can be obtained by integrating with a periodic patch EBG

structure. By replacing the gap of the CSRR with PIN diodes and controlling the DC voltage, the polarization of the antenna could be switched among LHCP, RHCP and LP, respectively. The measured impedance bandwidth of LHCP and RHCP are about 120 MHz and 110 MHz (3.47 GHz{3.59 GHz, 3.48 GHz{3.59 GHz}), while the bandwidth of LP is 70 MHz (3.52 GHz{3.59 GHz). And 3 dB AR bandwidth of both LHCP and RHCP are about 60 MHz. Measured results are in good agreement with simulated results, which shows that the antenna can be a good candidate for wireless communication systems.

ACKNOWLEDGMENT

This work is supported partly by the Natural Science Basic Research Plan in Shaanxi Province of China (No. 2013JZ019), National Key Laboratory Foundation, Fundamental Research Funds for the Central Universities (K5051202051), National Key Laboratory Foundation, and Foundation for the Returned Overseas Chinese Scholars, State Education Ministry and Shaanxi Province.

REFERENCES

- [1] Chen, C.-H. and E. K. N. Yung, "A novel unidirectional dual-band circularly-polarized patch antenna," *IEEE Transactions on Antennas and Propagation*, Vol. 59, No. 8, 3052{3057, 2011.
- [2] Chang, T.-N., J.-M. Lin, and Y. G. Chen, "A circularly polarized ring-antenna fed by a serially coupled square slot-ring," *IEEE Transactions on Antennas and Propagation*, Vol. 60, No. 2, 1132{ 1135, 2012.
- [3] Bahl, I. J. and P. Bhartia, *Microstrip Antennas*, Artech House, MA, 1980
- [4] Fu, Y. Q., Q. R. Zheng, Q. Gao, and G. H. Zhang, "Mutual coupling reduction between large antenna arrays using electromagnetic bandgap (EBG) structures," *Journal of Electromagnetic Waves and Application*, Vol. 20, No. 6, 819{825, 2006.

- [5] Dong, Y., H. Toyao, and T. Itoh, "Design and characterization of miniaturized patch antennas loaded with complementary split-ring resonators," *IEEE Transactions on Antennas and Propagation*, Vol. 60, No. 2, 772{785, 2012.
- [6] Zhang, H., Y.-Q. Li, X. Chen, Y.-Q. Fu, and N.-C. Yuan, "Design of circular/dual-frequency linear polarization antennas based on the anisotropic complementary split ring resonator," *IEEE Transactions on Antennas and Propagation*, Vol. 57, No. 10, 3352{3355, 2009.
- [7] P^oaum, S., P. L. Thuc, G. Kossiavas, and R. Staraj, "Performance enhancement of a circularly polarized patch antenna for radio frequency identification readers using an electromagnetic band-gap ground plane," *Microwave Optical Technology Letter*, Vol. 55, 1599{1602, 2013.
- [8] Li, B., J. Hong, and B. Wang, "Switched band-notched UWB/dual-band WLAN slot antenna with inverted S-shaped slots," *IEEE Antennas Wireless Propagation Letter*, Vol. 11, 572{575, 2012.
- [9] Abutarboush, H. F., R. Nilavalan, S. W. Cheung, K. M. Nasr, T. Peter, D. Budimir, and H. Al-Raweshidy, "A reconfigurable wideband and multiband antenna using dual-patch elements for compact wireless devices," *IEEE Transactions on Antennas and Propagation*, Vol. 60, No. 1, 36{43, 2012.
- [10] Yoon, W.-S., J.-W. Baik, H.-S. Lee, S. Pyo, S.-M. Han, and Y.-S. Kim, "A reconfigurable circularly polarized microstrip antenna with a slotted ground plane," *IEEE Antennas Wireless Propagation Letter*, Vol. 9, 1161{1164, 2010.
- [11] Yang, X.-X., B.-C. Shao, F. Yang, A. Z. Elsherbeni, and B. Gong, "A polarization reconfigurable patch antenna with loop slots on the ground plane," *IEEE Antennas Wireless Propagation Letter*, Vol. 11, 69{72, 2012.
- [12] High Frequency Structure Simulator, Ansys Corporation.