

Harmonic Compensation Due To Rectifiers Using Band With Controlled Shunt Active Power Filter

L.Dinesh

Assistant Professor,
Department of EEE,
ANITS, Sangivalasa,
Visakhapatnam, India.

J Uday Venkatesh

Assistant Professor,
Department of EEE,
ANITS, Sangivalasa,
Visakhapatnam, India.

L. Vijay

Assistant Professor,
Department of EEE,
ANITS, Sangivalasa,
Visakhapatnam, India.

M.S.M. Divakar

Assistant Professor,
Department of EEE,
ANITS, Sangivalasa,
Visakhapatnam, India.

Abstract:

This paper proposes a new control method of three phase active power filters for reducing the dc capacitor voltage fluctuations and source current harmonics for non linear loads. The proposed control method introduces a new k-step compensator, which maintains the mean active power flowing into the dc capacitor at zero every $1/(k-1)$ ac line period. Therefore, the compensator can suppress the current due to non linearity. The control technique includes time delay reference currents which are compared with dc bus voltage generated currents. A pwm technique is used to generate pulses for the filter. A hysteresis technique can be replaced for faster operation of the converter and to further improvement of the performance.

Key words: Active power filters, dc capacitor voltage fluctuations, harmonic detection, load change, transient response.

I. INTRODUCTION:

Active power filters (APFs) have been developed and put into practical use for reducing the harmonic current produced by harmonic-producing loads in power systems [1], [2]. An APF reduces the source harmonic current by absorbing harmonic current which is anti-phase from the harmonic currents drawn by the harmonic-producing load. The APF requests a high-accuracy and a small-phase delay in the harmonic-detection and the current-control circuit and/or method to improve the compensation performance [3], [4]. Various control methods have been proposed mainly to improve harmonic compensation characteristics [5]–[12]. Nakata et al.[6]have proposed the application of moving average

filters to a comprehensive harmonic detection method for reducing the steady-state error. The current control performance of the APF is also an important factor for the improvement of harmonic compensation characteristics. A deadbeat control method [7] and a quadruple sampling technique for single-phase APFs[11] have been reported to expand the current control bandwidth. Any control method causes an amount of instantaneous active power flowing into/out of APFs, which is formed by the source voltage and the compensating current.

Akagiet al.[17]have reported that compensating only instantaneous reactive power causes no dc-capacitor voltage fluctuations. However, harmonic compensation performance decreases. On the other hand, dc-capacitor voltage control methods have also been discussed to improve the control stability and to reduce the voltage fluctuations[16],[18].A control method using the Lyapunov function has been proposed to improve the stability of the feedback control of the dc-capacitor voltage against the quick reference change [18]. The authors have proposed a harmonic detection method for a single-phase APF, which can greatly reduce the capacitance value [19]. The harmonic detection method in [19] can control the energy flowing into the dc capacitor to be zero for one source cycle after the sudden load change.

However, the harmonic detection method is not enough to decrease the voltage fluctuations in a three-phase APF because the transient voltage fluctuations is much greater than the voltage ripple in steady states. This paper proposes a new control method capable of reducing the

capacitance value of the dc capacitor for three-phase APFs. The proposed method employs a newly-developed k-step compensator to reduce undesired energy flowing into or out of the dc capacitor. As a result, the proposed method makes it possible to restrain the voltage fluctuations across the dc capacitor even when a sudden load change occurs. Thus, the APF using the proposed method can continuously operate without overvoltage in transient states even when a small dc capacitor is employed. This paper theoretically analyzes characteristics of the newly developed k-step compensator paying attention to the reducing performance of the voltage fluctuations. In this paper, the harmonic detection method in [19] is referred to a two-step compensator.

Since the rapid development of the semiconductor industry, power electronics devices have gained popularity in our daily used electrical house-hold appliances. Although these power electronics devices have benefited the electrical and electronics industry, these devices are also the main source of power harmonics in the power system. These power harmonics are called electrical pollution which will degrade the quality of the power supply.

As a result, filtering process for these harmonics is needed in order to improve the quality of the power supply. Thus, active power filter seems to be a viable alternative for power conditioning to control the harmonics level in the power system nowadays. Power system normally operates at 50 or 60 Hz. However, saturated devices such as transformers, arcing loads such as florescent lamp and power electronic devices will produce current and voltage components with higher frequencies into the power line.

These higher frequencies of current and voltage components are known as the power harmonics. The harmonics disturbances in the power supply are caused by the nonlinearity characteristic of the loads. Due to the advantages in efficiency and controllability of power electronic devices, their applications can be found in almost all power levels.

II.CONTROL OF HARMONICS:

Passive filters:

Traditional solutions for these problems are power-factor-correction (PFC) techniques, passive filters due to their easy design, simple structure, low cost and high efficiency. These usually consist of a bank of tuned LC filters to suppress current harmonics generated by nonlinear loads. Passive filters have many disadvantages, such as Resonance, Large size, Fixed compensation character, Possible overload, With the PFC approach, a PFC unit is usually in cascade in the energy pass, which processes all the power and corrects the current to unity power factor. Those kinds of approaches are usually suitable for low-power (less than 5kVA) applications.

Active filters:

To overcome the disadvantages due to Passive Filters, Active Power Filters (APFs) have been presented as a current-harmonic compensator for reducing the total harmonic distortion of the current and correcting the power factor of the input source. The Active Power Filter is connected in parallel with a nonlinear load. The approach is based on the principle of injecting harmonic current into the ac system, of the same amplitude and reverse phase to that of the load current harmonics.. This will thus result in sinusoidal line currents and unity power factor in the input power system. In this case, only a small portion of the energy is processed, which may result in overall higher energy efficiency and higher power processing capability. These kinds of approaches are applicable for low-power (less than 5kVA) to high-power applications (around 100kVA).

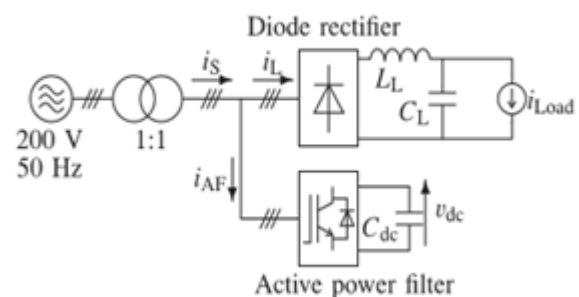

Figure 1: Block diagram of proposed APF

A three-phase shunt APF is typically composed of a three-phase bridge converter and control circuitry. Most of the previous control approaches need to sense the load current and calculate its harmonics and reactive components in order to generate the reference for controlling the current of a bridge converter. Those control methods require fast and real-time calculation; therefore, a high-speed digital microprocessor and high-performance A/D converters are necessary, which yields high cost, complexity, and low stability.

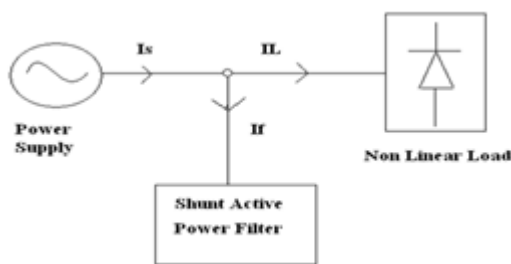

Figure 2: Basic principle of harmonic currents compensations

The harmonic current compensations by the active power filter are controlled in a closed loop manner. The active power filter will draw and inject the compensating current, I_f to the line based on the changes of the load in the power supply system. The supply line current, I_s is described by the following equation,

$$I_s = I_f + I_l$$

The line current, I_s is shaped to be sinusoidal by adding the compensating current, I_f into the distorted load current, I_l .

III. CONTROL SCHEME OF ACTIVE POWER FILTERS:

The main aim of an active power filter (APF) is to generate compensating currents into the power system for canceling the current harmonics contained in the nonlinear load current. This will thus result in sinusoidal line currents and unity power factor in the input power system. The exclusive features of this proposed PWM controlled APF are concluded as follows:

(a) The reference frame transformation and a digital low pass filter are used to compute the harmonics of the nonlinear load current.

(b) The voltage decouplers and pole-zero cancellation method are used in the current controllers of the active power filter to provide fast current harmonic compensation and simplify the control scheme.

(c) The delay times of both current response of an active power filter and DC-link voltage feedback are considered. This results in decreasing the settling time of the DC-link voltage and reducing the high frequency current harmonic components of the power system.

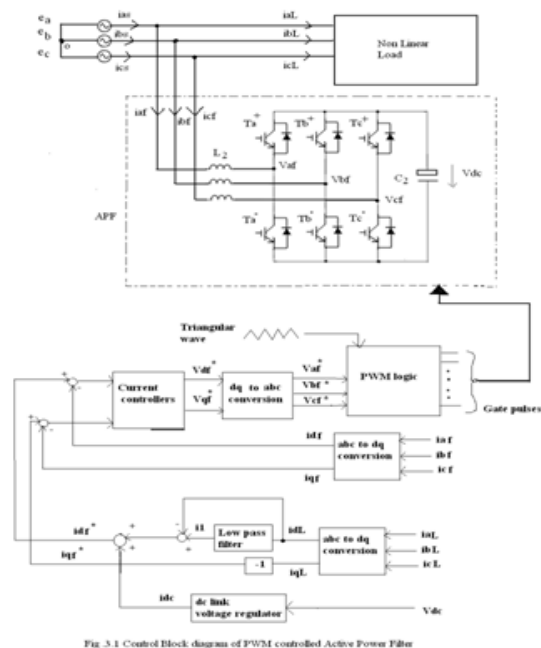

Fig. 3.1 Control Block diagram of PWM controlled Active Power Filter

Figure 3: control block diagram of PWM controlled APF

e_a, e_b, e_c and v_{af}, v_{bf}, v_{cf} represent the phase voltages of a power system and the input voltages of a power converter, i_{af}, i_{bf}, i_{cf} and v_{dc} denote the input currents of the active power filter and the DC-link voltage, respectively. Neglecting the reactors L_s of the input power system, the differential equations of the three-phase active Power filter can be described as follows.

$$L_2 \frac{d}{dt} i_{af} = e_a - R_2 i_{af} - v_{af}$$

$$L_2 \frac{d}{dt} i_{bf} = e_b - R_2 i_{bf} - v_{bf}$$

$$L_2 \frac{d}{dt} i_{cf} = e_c - R_2 i_{cf} - v_{cf}$$

$$C_2 \frac{d}{dt} v_{dc} = f_a i_{af} + f_b i_{bf} + f_c i_{cf}$$

Where C_2 is the capacitance of the DC-link capacitor, R_2 and L_2 are the resistance and inductance of the active power filter line reactors, respectively, f_a, f_b, f_c are Switching functions, and the possible values are $0, \pm \frac{1}{3}$ and $\pm \frac{2}{3}$. For model analysis and controller design, the three-phase voltages, currents and switching functions can be transformed to a $d-q-o$ rotating frame. This yields,

$$\begin{bmatrix} x_d \\ x_q \\ x_o \end{bmatrix} = \frac{2}{3} \begin{bmatrix} \sin \theta_e & \sin \left(\theta_e - \frac{2\pi}{3} \right) & \sin \left(\theta_e + \frac{2\pi}{3} \right) \\ \cos \theta_e & \cos \left(\theta_e - \frac{2\pi}{3} \right) & \cos \left(\theta_e + \frac{2\pi}{3} \right) \\ \frac{1}{2} & \frac{1}{2} & \frac{1}{2} \end{bmatrix} \begin{bmatrix} x_a \\ x_b \\ x_c \end{bmatrix}$$

Finally

$$L_2 \frac{d}{dt} i_d = e_d - R_2 i_d + \omega_e L_2 i_q - v_d$$

$$L_2 \frac{d}{dt} i_q = e_q - R_2 i_q - \omega_e L_2 i_d - v_q$$

$$C_2 \frac{d}{dt} v_{dc2} = \frac{3}{2} (f_d i_d + f_q i_q)$$

where

$$v_d = f_d v_{dc2}$$

$$v_q = f_q v_{dc2}$$

ω_e is the frequency of the power system and the subscripts 'd' and 'q' are used to denote the components of the d- and q-axis in the rotating frame, respectively. Equations will be used to derive the block diagram of the active power filter and calculate the input voltage commands of power converter.

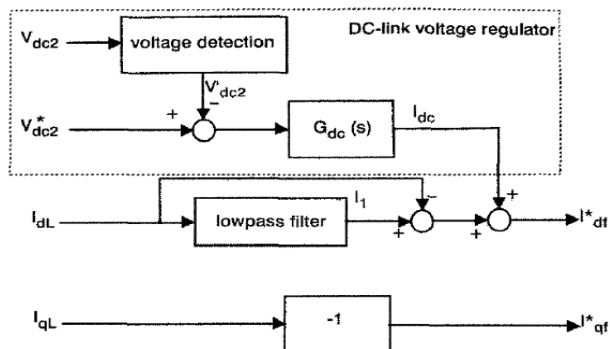

Figure 4: Block diagram of d- and q-axis reference current of active power filter

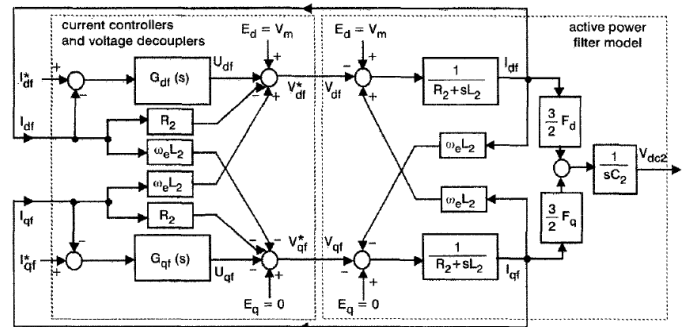

Figure 5: Control block diagram of d- and q-axis current controllers of active power filter.

IV TEST SYSTEM MODEL:

In the existing literature, the analytical model of an active power filter is complicated and is difficult for the design of current regulators and DC-link voltage regulators. To improve these disadvantages, a current controller with voltage decoupler is presented here to simplify the analytical model. This Section first discusses the time-delay concepts including reference current delay, current response delay and the DC-link voltage feedback delay. Considering these delay times, the analytical model and closed-loop transfer functions for the active power filter are then derived. Finally, the boundary conditions between the stable and unstable operations for the active power filter system are discussed in detail.

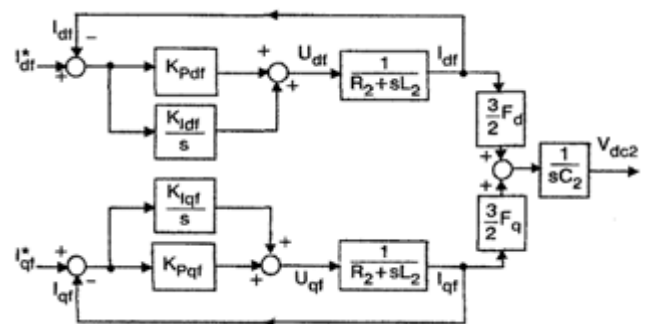

Figure 6: Equivalent control block diagram d- and q-axis current control loops of active power filter.

Assume that the $d-q$ voltage decouplers for current control loops are fully decoupled and the $d-q$ voltage commands are not saturated for linear operation of PWM modulation. The $d-q$ current control loops can be simplified for the d-axis current control loop, the closed-loop current transfer function can be derived as.

$$\frac{I_q(s)}{\dot{I}_q(s)} = \frac{\frac{K_{Pq}}{L_2} s + \frac{K_{Iq}}{L_2}}{s^2 + \frac{K_{Pq} + R_2}{L_2} s + \frac{K_{Iq}}{L_2}}$$

The block diagram of a DC-link voltage regulator is shown in Figure. The proportional-integral controller $G_{dc}(s)$ for the DC-link voltage control loop in equation.(3.18) has the Characteristic

$$G_{dc}(s) = \left(K_{Pdc} + \frac{K_{Idc}}{s} \right)$$

To obtain a smooth current command i_{dc} for the Dc-link voltage regulator, the voltage detection using a first order low pass filter is added to the DC-link voltage feedback Control loop as shown in figure where T_{dc} is the delay time constant between the real DC-link voltage V_{dc2} and the measured DC-link voltage V'_{dc2} , and ω_{dc} represents the Cut off frequency of the low pass filter of the DC-link voltage feedback.

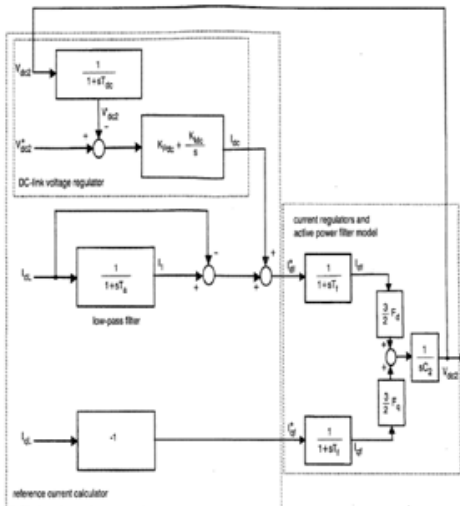

Figure 7: 8 Analytical model for active power filter

The turn on and turn off instants of inverter switches should be such that the load and the connected RES could appear as balanced load to the system. The dc link voltage, V_{dc} is sensed at a regular interval and is compared with its reference counterpart V_{dc}^* . The error

signal is processed in a PI-controller. The output of the pi controller is denoted as I_m .

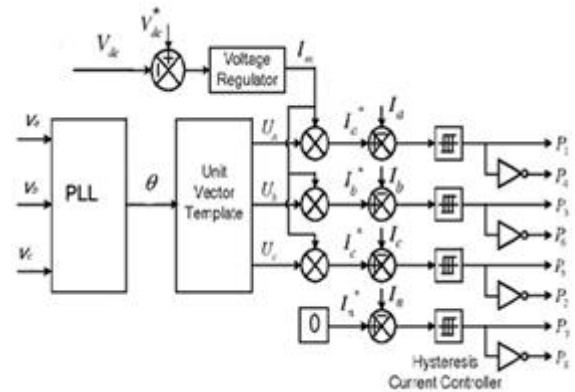

Figure 8: control scheme of the model

Total system is shown as five sub systems; those are Three-phase ac source, which is supplying for Non-linear load. Active Power Filter (APF), that is connected parallel to the load and also PWM controller subsystem which is giving pulses to the APF such that it will inject compensation currents into the power line which are opposite in phase to the harmonic currents introduced by the nonlinear loads. Total controller subsystem will provide reference voltages to the PWM controller subsystem. Here the reference voltages are compared with the triangular wave which is having frequency of 10KHZ and produced the switching gate pulses for the power converter.

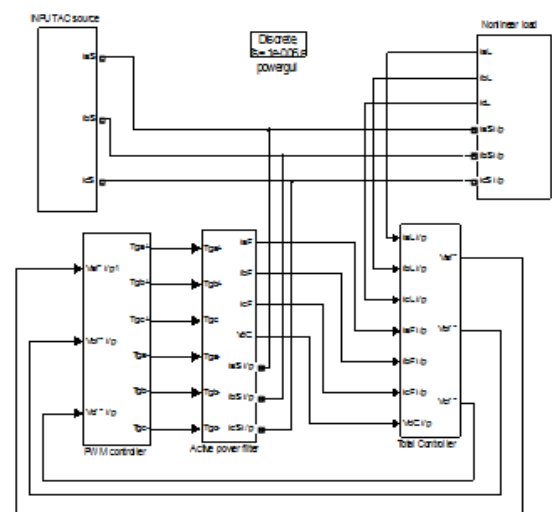

Figure 9: Simulink Model of PWM Controlled APF for the Three-Phase Power System

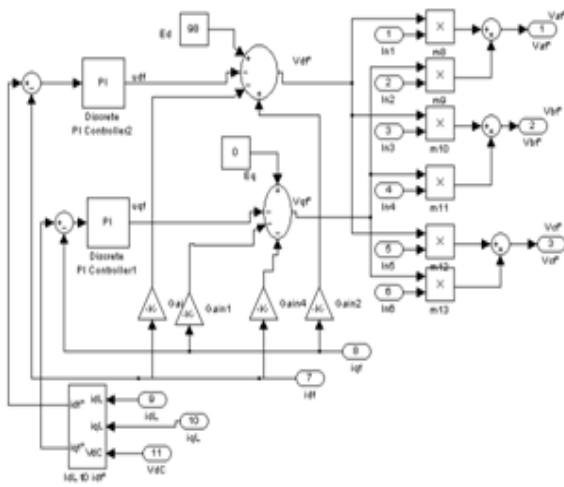

Figure 10: Simulink Model for d and q axis current controllers of APF

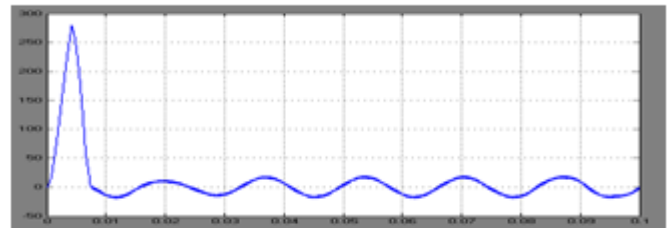

Figure 13: Single phase source current with PWM technique pi controller



Figure 14: Converter DC voltage under operating condition using pwm

V. RESULTS:

The obtained results of test system are

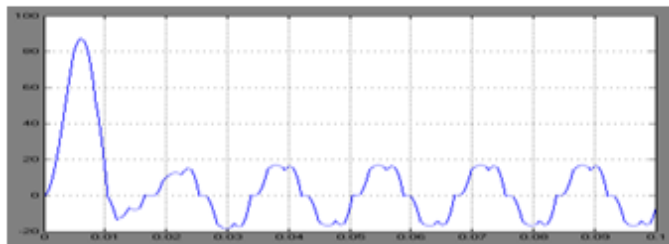

Figure 11: Source current without filter

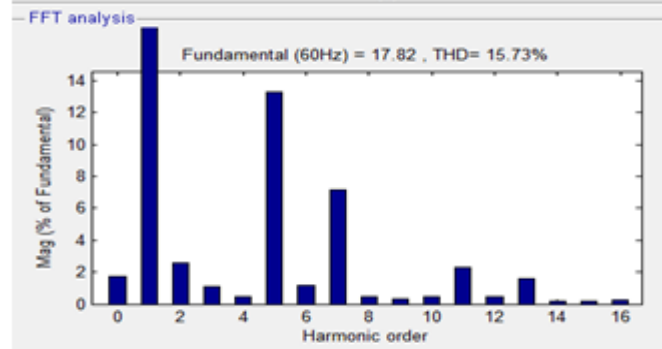
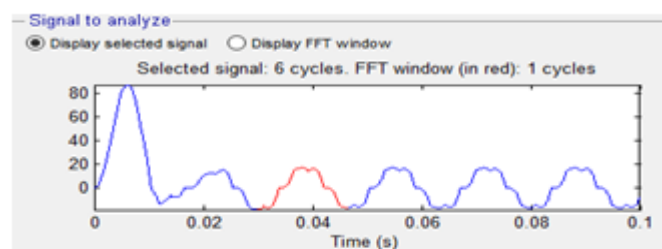

Figure 12: THD without active filter

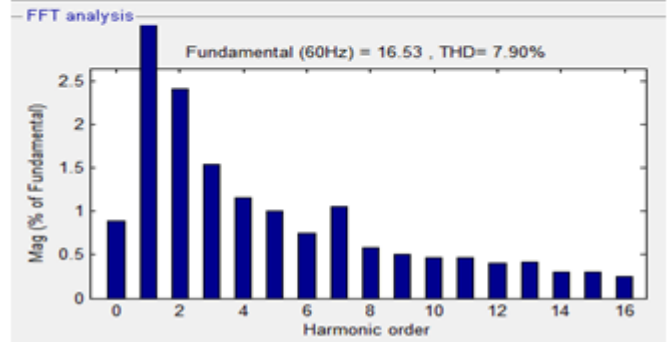
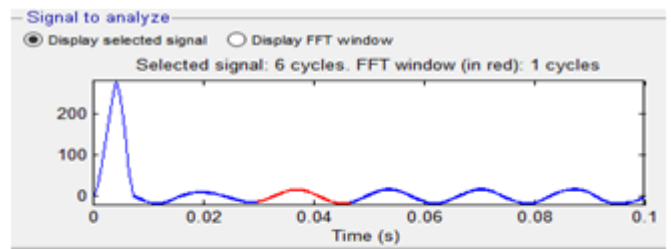

Figure 15: THD with pwm technique

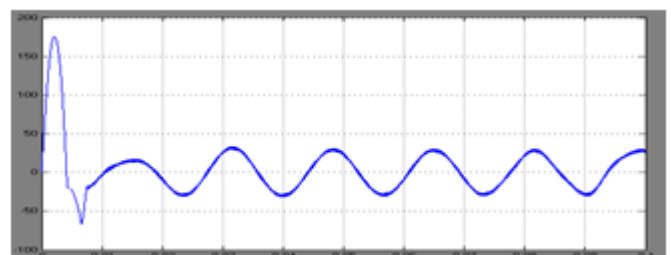

Figure 15: Source current with hysteresis controller

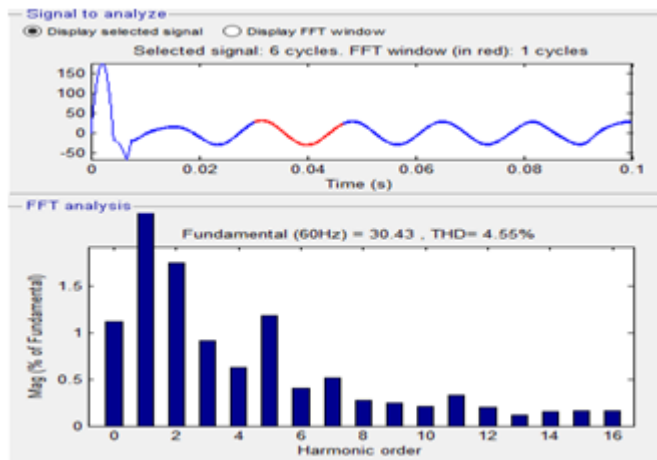

Figure 16: THD of source current using hysteresis controller

VI. CONCLUSION:

This project has proposed a new harmonic current detection method which can reduce the current harmonics and voltage fluctuations caused by non linear loads. The controller input signals are from dc bus voltage and load currents with changes when there are any external disturbances. by using general PWM technique to the proposed detection technique the total harmonics distortion reduced to 7.90% from 15.73%. And if the pulse generation technique is replaced by using hysteresis control the THD is reduced to 4.55%.from the above results we can conclude that by using hysteresis based current control technique we get better results.

VII. REFERENCES:

- [1] S. Bhattacharya, T. M. Frank, D. M. Divan, and B. Banerjee, "Active filter system implementation," *IEEE Ind. Appl. Mag.*, vol. 4, no. 5, pp. 47–63, Sep./Oct. 1998.
- [2] B. Singh, K. Al-Haddad, and A. Chandra, "A review of active filters for power quality improvement," *IEEE Trans. Ind. Electron.*, vol. 46, no. 5, pp. 960–971, Oct. 1999.
- [3] L. Asiminoael, F. Blaabjerg, and S. Hansen, "Detection is key—Harmonic detection methods for active power filter applications," *IEEE Ind. Appl. Mag.*, vol. 13, no. 4, pp. 22–33, Jul./Aug. 2007.

- [4] A. Bhattacharya, C. Chakraborty, and S. Bhattacharya, "Shunt compensation," *IEEE Ind. Electron. Mag.*, vol. 3, no. 3, pp. 38–49, Sep. 2009.
- [5] T. Ohnishi and H. Yamauchi, "Active filter by instantaneous ripple line power reduction," *IEEJ Trans. Ind. Appl.*, vol. 111, no. 11, pp. 921–929, 1991.
- [6] A. Nakata, A. Ueda, and A. Torii, "A method of current detection for an active power filter applying moving average to pq-theory," in *Proc. 29th Annu. IEEE Power Electron. Specialists Conf.*, 1998, vol. 1, pp. 242–247.
- [7] P. Jintakosonwit, H. Fujita, and H. Akagi, "Control and performance of a fully-digital-controlled shunt active filter for installation on a power distribution system," *IEEE Trans. Power Electron.*, vol. 17, no. 1, pp. 132–140, Jan. 2002.
- [8] W. Merk, H. Stemmler, and J. Allmeling, "Stationary-frame generalized integrators for current control of active power filters with zero steady-state error for current harmonics of concern under unbalanced and distorted operating conditions," *IEEE Trans. Ind. Appl.*, vol. 38, no. 2, pp. 523–532, Mar./Apr. 2002.
- [9] P. Jintakosonwit, H. Akagi, H. Fujita, and S. Ogasawara, "Implementation and performance of automatic gain adjustment in a shunt-active filter for harmonic damping throughout a power distribution system," *IEEE Trans. Power Electron.*, vol. 17, no. 3, pp. 438–447, May 2002.
- [10] M. E. Ortuzar, R. E. Carmi, J. W. Dixon, and L. Moran, "Voltage-source active power filter based on multilevel converter and ultracapacitor DC link," *IEEE Trans. Ind. Electron.*, vol. 53, no. 2, pp. 477–485, Apr. 2006.