

ZigBee-Based Communication System for Data Transfer within Future Micro grids

Penti Rama Krishna

M.Tech,

Kshatriya College of Engineering,
Perkit, Armour (M).

Inala Raghava Krishna, M.Tech

Assistant Professor,

Kshatriya College of Engineering,
Perkit, Armour (M).

Abstract:

By embedding computational capabilities in all kinds of objects and living beings, it will be possible to provide a qualitative and quantitative leap in several sectors: healthcare, logistics, domestics, entertainment, and so on. Due to the drastic changes in technology in the last decade, so many advancements were introduced in electricity departments. The electricity bill can be paid now through E-Seva centers, Net-banking and even through mobile phones.

Literature Survey:

Existing Method:

In this project electricity consumption by the user i.e. Units consumed in that meter will displayed on 16X2 LCD is provided to read units available. Whenever there is a change in count value / units in the meter gets changed.

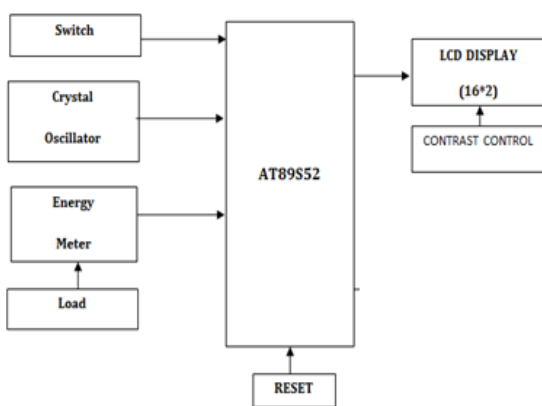

Drawback:

There is no wireless communication.
More power consumption by controller used.

Proposed System:

In this project electricity consumption by the user i.e. Units consumed in that meter will be sent to PC using zigbee module and also 16X2 LCD is provided to read units available. Whenever there is a change in count value / units in the meter gets changed, these values are displayed on LCD. Here we are using zigbee for the purpose of communication.

BLOCK DIAGRAM

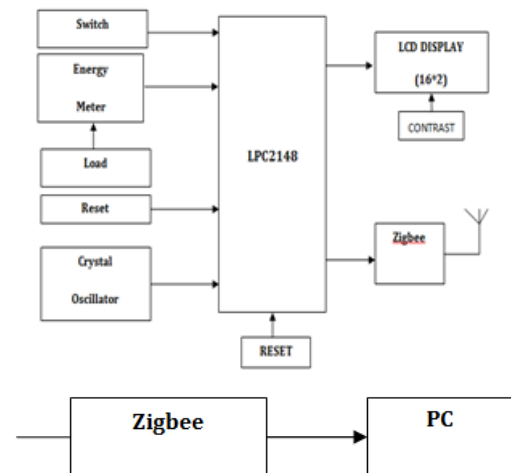

I. Hardware Modules:

A. LPC2148 Controller:

The LPC2148 are based on a 16/32 bit ARM7TDMI-S™ CPU with real-time emulation and embedded trace support, together with 128/512 kilobytes of embedded high speed flash memory.

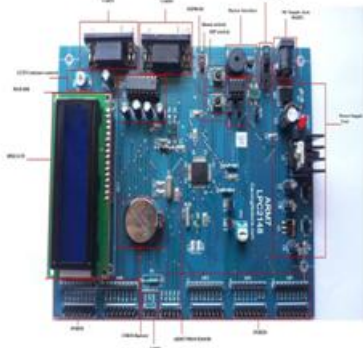

A 128-bit wide memory interface and unique accelerator architecture enable 32-bit code execution at maximum clock rate. For critical code size applications, the alternative 16-bit Thumb Mode reduces code by more than 30% with minimal performance penalty. With their compact 64 pin package, low power consumption, various 32-bit timers, 4- channel 10-bit ADC, USB PORT, PWM channels and 46 GPIO lines with up to 9 external interrupt pins these microcontrollers are particularly suitable for industrial control, medical systems, access control and point-of-sale. With a wide range of serial communications interfaces, they are also very well suited for communication gateways, protocol converters and embedded soft modems as well as many other general-purpose applications.

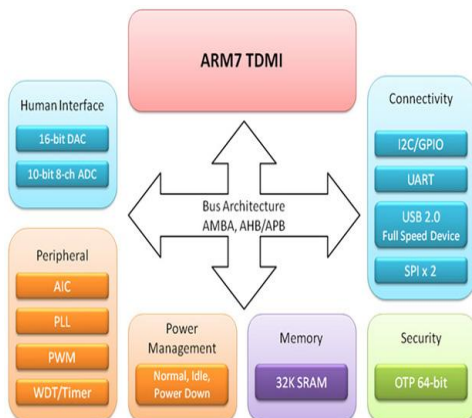

B. Zigbee:

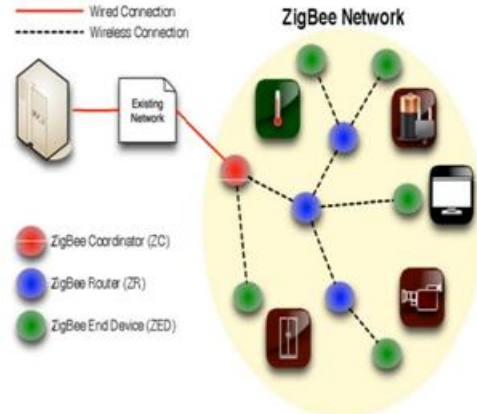

It is the wireless device for transmitting and receiving purpose or simply it called as Transceiver. Zigbee is based on the IEEE802.15.4 protocol. The range of the Zigbee is covered as 100m. Its range is 10 times better than bluetooth device so it can be more preferable one in wireless device. The data rate is very low for transmission while using this device.

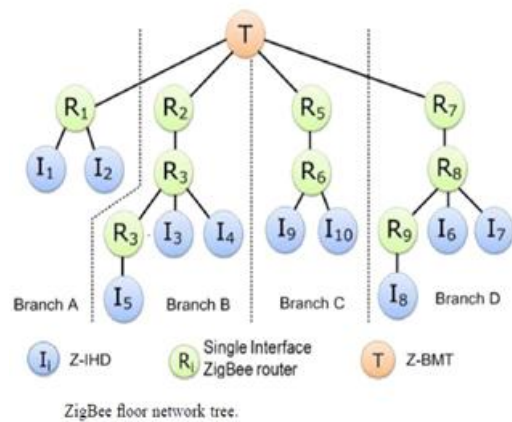

C. Grid:

The term grid usually refers to a network, and should not be taken to imply a particular physical layout or breadth. Grid may also be used to refer to an entire electrical network, a regional transmission network or may be used to describe a sub network such as a local utility's transmission grid or distribution grid.

Schematic Representation of Project:

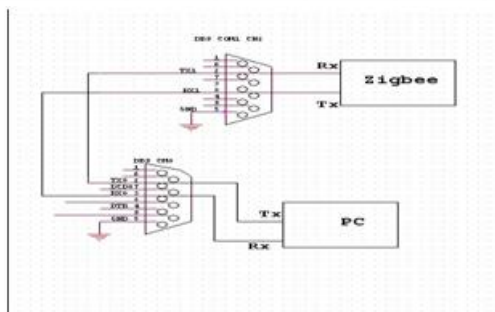
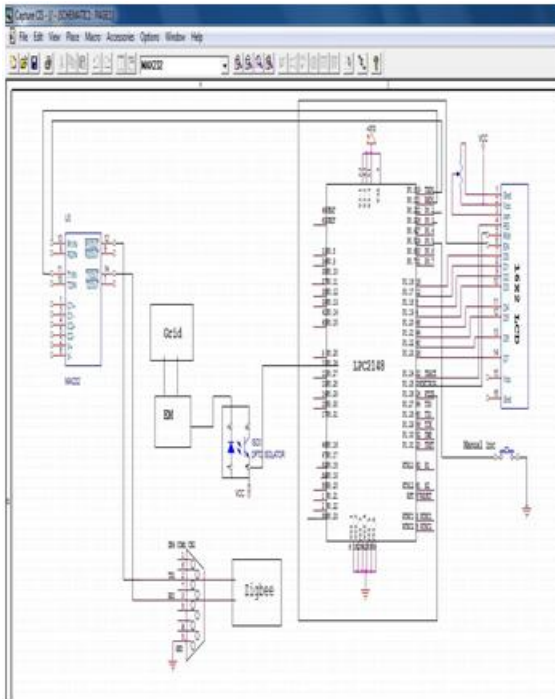

III. SOFTWARE DETAILS:

Keil:

Keil compiler is a software used where the machine language code is written and compiled. After compilation, the machine source code is converted into hex code which is to be dumped into the microcontroller for further processing. Keil compiler also supports C language code.

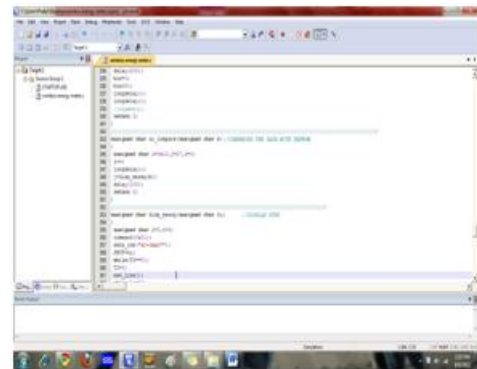

Flash Magic:

Flash Magic is a tool which is used to program hex code in EEPROM of micro-controller. It is a freeware tool. It only supports the micro-controller of Philips and NXP. It can burn a hex code into that controller which supports ISP (in system programming) feature. Flash magic supports several chips like ARM Cortex M0, M3, M4, ARM7 and 8051.



II. PERFORMANCE EVALUATION:

The performance evaluation is divided into two parts: ZigBee mesh floor (horizontal communication) network and BN (vertical communication).

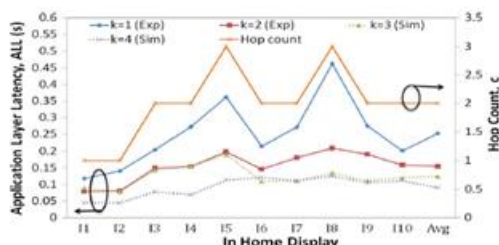

ALL and c of $I_1 - I_{10}$ for $k = 1-4$ and $n = 1$.

IV. Results:

Simulation Results

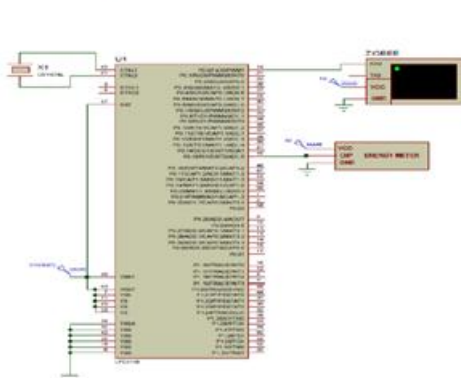

V. ADVANTAGES:

1. Ease of maintenance
2. Accessing the data from other place
3. Less power consumption
4. Very faster communication

VI. APPLICATIONS:

1. Industrial Automation
2. Weather stations
3. Agricultural

VII. Conclusion:

To facilitate efficient deployment of metering for existing buildings this concept is very helpful using LPC2148 and Zigbee.

VIII. References:

- P. Siano, C. Cecati, H. Yu, and J. Kolbusz, "Real time operation of smart grids via FCN networks and optimal power flow," *IEEE Trans. Ind. Inf.*, vol. 8, no. 4, pp. 944–952, Nov. 2012.
- W. Su, H. Eichi, W. Zeng, and M. Y. Chow, "A survey on the electrification of transportation in a smart grid environment," *IEEE Trans. Ind. Inf.*, vol. 8, no. 1, pp. 1–10, Feb. 2012.
- F. Benzi, N. Anglani, E. Bassi, and L. Frosini, "Electricity smartmeters interfacing the households," *IEEE Trans. Ind. Electron.*, vol. 58, no. 10, pp. 4487–4494, Oct. 2011.

- J. Haase, J. M. Molina, and D. Dietrich, "Power-aware system design of wireless sensor networks: Power estimation and power profiling strategies," *IEEE Trans. Ind. Inf.*, vol. 7, no. 4, pp. 601–613, Nov. 2011.
- P. Palensky and D. Dietrich, "Demand side management: Demand response, intelligent energy systems, smart loads," *IEEE Trans. Ind. Inf.*, vol. 7, no. 3, pp. 381–388, Aug. 2011.
- Y. H. Jeon, "QoS requirements for the smart grid communications system," *Int. J. Comput. Inf. Sci.*, vol. 11, no. 3, pp. 86–94, 2011.
- Y. Simmhan, Q. Zhou, and V. K. Prasanna, "Chapter: Semantic information integration for smart grid applications," in *Green IT: Technologies and Applications*. Berlin, Germany: Springer, 2011.
- Z. M. Fadlullah, M. M. Fouda, N. Kato, A. Takeuchi, N. Iwasaki, and Y. Nozaki, "Toward intelligent machine-to-machine communications in smart grid," *IEEE Commun. Mag.*, vol. 49, no. 4, pp. 60–65, Apr. 2011.
- P. T. A. Quang and D. S. Kim, "Enhancing real-time delivery of gradient routing for industrial wireless sensor networks," *IEEE Trans. Ind. Inf.*, vol. 8, no. 1, pp. 61–68, Feb. 2012.
- U.S. DOE, "Locke, Chu Announce Significant Steps in Smart Grid Development," 2009. [Online]. Available: <http://www.energy.gov/news2009/7408.htm>.
- Dept. Energy Commun., "Communications requirements of smart grid technologies," Oct. 5, 2010.