

Implementation of PV Solar Farm as Statcom during Night And Day Hours in a Distribution Network

G. Srinivasarao

Department of Electrical and Electronics Engineering,
MITK, Khammam, T.S - 507163, India.

ABSTRACT

This paper presents a new idea of using a (related to electricity controlled by light) (PV) solar farm inverter as STATCOM, called PV-STATCOM, for improving stable power move (from one place to another) limits of the interconnected transmission system. The whole inverter rating of the PV solar farm, which remains inactive during night time, is used with voltage and (slowing down movement) controls to improve stable power transmission limits. During daytime, the inverter ability (to hold or do something) left after real power production is used to complete the previously-mentioned goal. Short-lived (firm and steady nature/lasting nature/strength) studies are managed and did/done on a realistic single machine (without limits or an end) bus power system having a midpoint located PV-STATCOM using EMTDC/PSCAD test run (that appears or feels close to the real thing) software.

The PV-STATCOM improves the stable transmission limits (in a big/important way) in the night and in the day even while creating large amounts of real power.

Power move (from one place to another) increases are also (showed/shown or proved) in the same power system for: 1) two solar farms operating as PV-STATCOMs and 2) a solar farm as PV-STATCOM and an inverter-based wind farm with almost the same STATCOM controls. This novel use of a PV solar farm valuable thing can this way improve power transmission limits which would have otherwise needed/demanded expensive added/more equipment, such as series/shunt capacitors or separate flexible ac transmission system controllers.

1. INTRODUCTION

Flexible AC transmission system (FACTS) controllers are being increasingly considered to increase the available power transfer limits/capacity (ATC) of existing transmission lines [1]–[4], globally. New research has been reported on the nighttime usage of a photovoltaic (PV) solar farm (when it is normally dormant) where a PV solar farm is utilized as a STATCOM—a FACTS controller, for performing voltage control, thereby improving system performance and increasing grid connectivity of neighboring wind farms [5], [6]. New voltage control has also been proposed on a PV solar farm to act as a STATCOM for improving the power transmission capacity.

Although, [8] and [9] have proposed voltage-control functionality with PV systems, none have utilized the PV system for power transfer limit improvement. A full converter-based wind turbine generator has recently been provided with FACTS capabilities for improved response during faults and fault ride through capabilities.

This paper proposes novel voltage control, together with auxiliary damping control, for a grid-connected PV solar farm inverter to act as a STATCOM both during night and day for increasing transient stability and consequently the power transmission limit. This technology of utilizing a PV solar farm as a STATCOM is called “PV-STATCOM.” It utilizes the entire solar farm inverter capacity in the night and the remainder inverter capacity after real power generation during the

Cite this article as: G. Srinivasarao, " Implementation of PV Solar Farm as Statcom during Night And Day Hours in a Distribution Network", International Journal & Magazine of Engineering, Technology, Management and Research, Volume 4 Issue 11, 2017, Page 212-217.

day, both of which remain unused in conventional solar farm operation.

Similar STATCOM control functionality can also be implemented in inverter-based wind turbine generators during no-wind or partial wind scenarios for improving the transient stability of the system. Studies are performed for two variants of a single-machine infinite bus (SMIB) system. One SMIB system uses only a single PV solar farm as PV-STATCOM connected at the midpoint whereas the other system uses a combination of a PV-STATCOM and another PV-STATCOM or an inverter-based wind distributed generator (DG) with similar STATCOM functionality. Three-phase fault studies are conducted using the electromagnetic transient software MATLAB, and the improvement in the stable power transmission limit is investigated for different combinations of STATCOM controllers on the solar and wind farm inverters, both during night and day.

2. PV SOLAR PLANT CONTROL CIRCUIT

The synchronous generator is represented by a detailed sixth order model and a DC1A-type exciter. The transmission-line segments TL1, TL2, TL11, TL12, and TL22, shown in Fig. 1, are represented by lumped pi-circuits. The PV solar DG, as shown in Fig. 2, is modeled as an equivalent voltage-source inverter along with a controlled current source as the dc source which follows the $I-V$ characteristics of PV panels [11]. The wind DG is likewise modeled as an equivalent voltage-source inverter. In the solar DG, dc power is provided by the solar panels, whereas in the full-converter-based wind DG, dc power comes out of a controlled ac-dc rectifier connected to the PMSG wind turbines, depicted as “wind Turbine-Generator-Rectifier (T-G-R).” The dc power produced by each DG is fed into the dc bus of the corresponding inverter, as illustrated in Fig. 7.2. A maximum power point tracking (MPPT) algorithm based on an incremental conductance algorithm [12] is used to operate the solar DGs at its maximum power point all of the time and is integrated with the inverter controller [11]. The wind DG is also assumed to operate at its maximum power point, since this proposed control

utilizes only the inverter capacity left after the maximum power point operation of the solar DG and wind DG.

For PV-STATCOM operation during nighttime, the solar panels are disconnected from the inverter and a small amount of real power is drawn from the grid to charge the dc capacitor.

The voltage-source inverter in each DG is composed of six insulated-gate bipolar transistors (IGBTs) and associated snubber circuits as shown in Fig. 7.2. An appropriately large dc capacitor of size 200 Farad is selected to reduce the dc side ripple [13].

Each phase has a pair of IGBT devices which converts the dc voltage into a series of variable-width pulsating voltages, using the sinusoidal pulse width modulation (SPWM) technique [4]. An L-C-L filter [13] is also connected at the inverter ac side

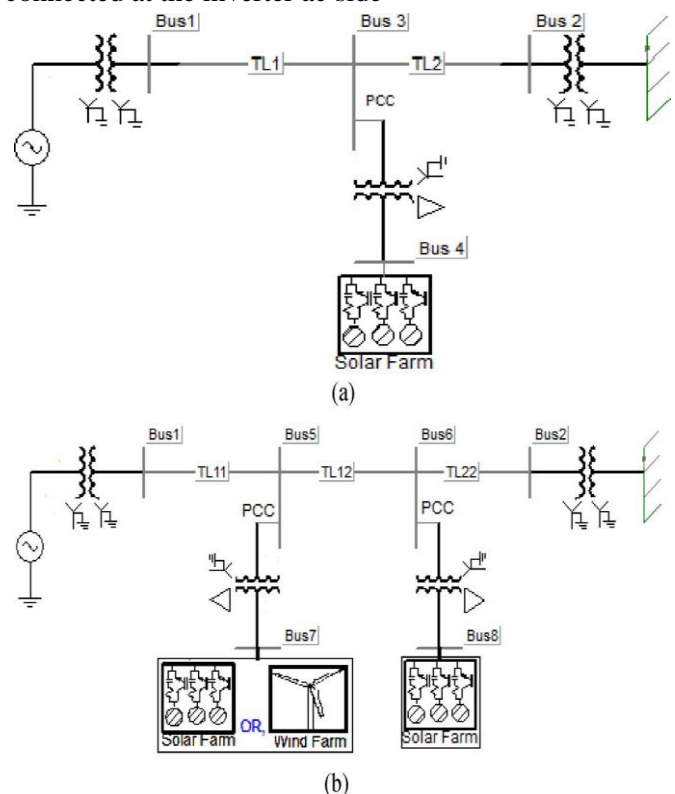

Fig. 1. Single-line diagram of (a) study system I with a single solar farm (DG) and (b) study system II with a solar farm (DG) and a solar/wind farm (DG).

3 CONTROL SYSTEM

1) CONVENTIONAL REACTIVE POWER CONTROL:

The conventional reactive power control only regulates the reactive power output of the inverter such that it can perform unity power factor operation along with dc-link voltage control [5]. The switching signals for the inverter switching are generated through two current control loops in - -0 coordinate system [5], [6]. The inverter operates in a conventional controller mode only provided that “Switch-2” is in the “OFF” position. In this simulation, the voltage vector is aligned with the quadrature axis, that is, 0 [5], [6], hence, is only proportional to which sets the reference for the upper control loop involving PI1. Meanwhile, the quadrature axis component is used for dc-link voltage control through two PI controllers (PI-2 and PI-3) [4], [6] shown in Fig. 2(b) according to the set point voltage provided by the MPPT and and injects all available real power “P” to the network [5].

To generate the proper IGBT switching signals (gt1, gt2, gt3, gt4, gt5, gt6), the – components (and) of the modulating signal are converted into three-phase sinusoidal modulating signals and compared with a high-frequency (5-kHz) fixed magnitude triangular wave or carrier signal.

2) PCC VOLTAGE CONTROL:

In the PCC voltage control mode of operation, the PCC voltage is controlled through reactive power exchange between the DG inverter and the grid. The conventional “ ” control channel is replaced by the PCC voltage controller in Fig. 2(b), simply by switching “Switch-1” to the position “A.” Hence, the measured signal at the PCC is compared with the preset reference value and is passed through the PI regulator, PI-4, to generate.

The rest of the controller remains unchanged. The upper current control loop is used to regulate the PCC voltage whereas the lower current control loop is used for dc voltage control and as well as for the supply of DG power to the grid. The amount of reactive power flow

from the inverter to the grid depends on set point voltage at the PCC. The parameters of the PCC voltage controller are tuned by a systematic trial-and-error method to achieve the fastest step response, least settling time, and a maximum overshoot of 10%–15%. The parameters of all controllers are given in the Appendix.

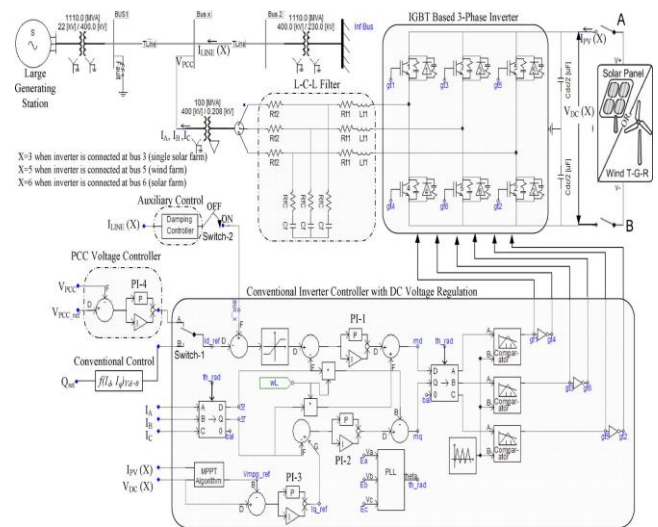

FIG2 Complete DG (solar/wind) system model with a damping controller and PCC voltage-control system.

3) Damping Control:

A novel auxiliary damping controller is added to the PV control system and shown in Fig. 7.2. (b). This controller utilizes line current magnitude as the control signal. The output of this controller is added with the signal. The transfer function of this damping controller is expressed.

At first, the base-case generator operating power level is selected for performing the damping control design studies. This power level is considered equal to the transient stability limit of the system with the solar farm being disconnected at night. At this operating power level, if a three-phase fault occurs at Bus 1, the generator power oscillations decay with a damping ratio of 5%. The solar farm is now connected and operated in the PV-STATCOM mode. The parameters of the damping controller are selected as follows. The washout time constant is chosen to allow the generator electromechanical oscillations in the frequency range up to 2 Hz to pass through [11]. The gain , time constants ,

and are sequentially tuned to obtain the fastest settling time of the electromechanical oscillations at the base-case generator power level through repetitive simulations. Thus, the best combination of the controller parameters is obtained with a systematic hit-and-trial technique, and the parameters are given in the Appendix. It is emphasized that these controller parameters are not optimal and better parameters could be obtained by following more rigorous control-design techniques [9], [12]. However, the objective of this paper is only to demonstrate a new concept of using a PV solar farm inverter as a STATCOM using these reasonably good controller parameters.

4 SIMULATION OF PROPOSED WORK

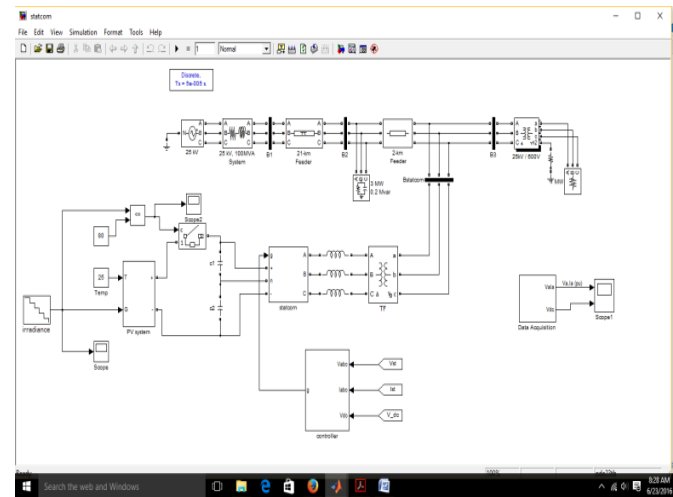

SOLAR pv MODEL

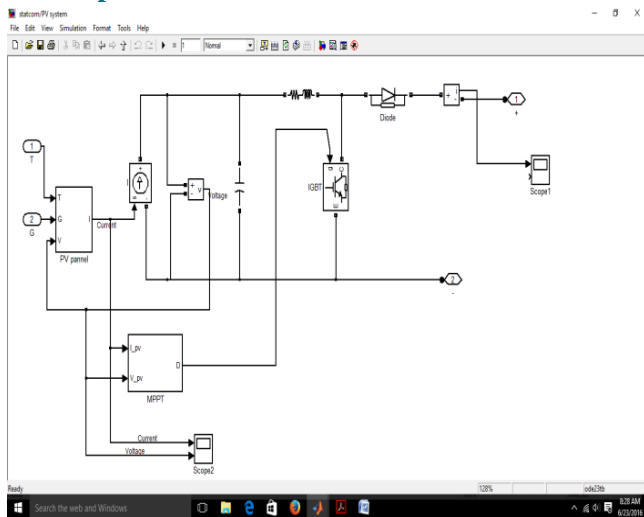

SOLAR PV INVERTER

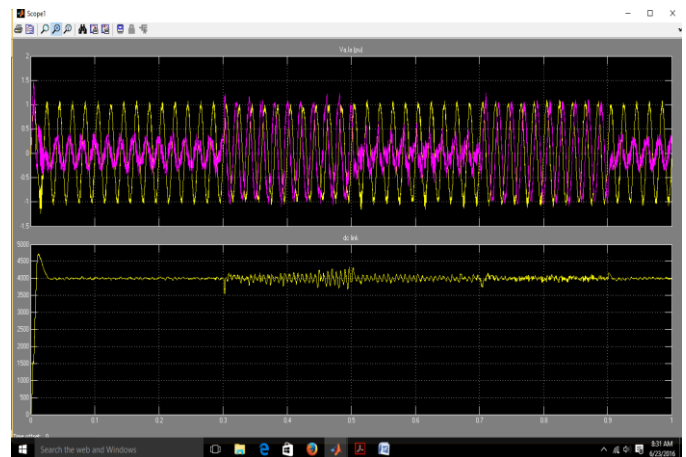
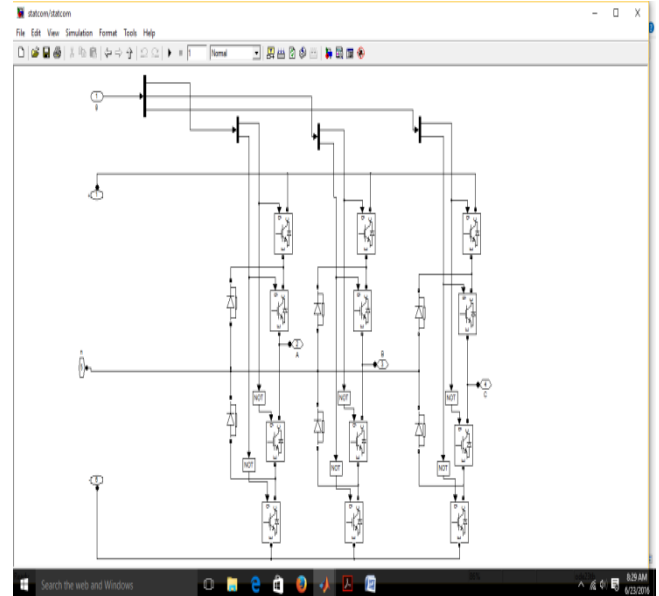

BUS1, BUS2, BUS 3VOLTAGES

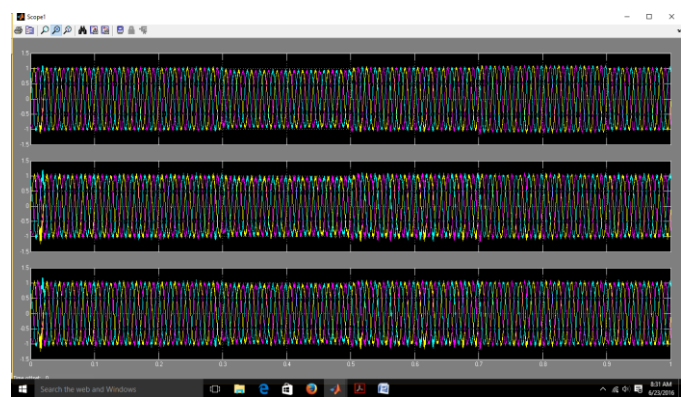

**Bus 3 CURRENTS, STATCOM VOLTAGE AND
STATCOM CURRENTS**

5. CONCLUSION

Solar farms are idle during nights. A novel patent-pending control paradigm of PV solar farms is presented where they can operate during the night as a STATCOM with full inverter capacity and during the day with inverter capacity remaining after real power generation, for providing significant improvements in the power transfer limits of transmission systems. This new control of PV solar system as STATCOM is called PV-STATCOM. The effectiveness of the proposed controls is demonstrated on two study SMIB systems: System I has one 100-MW PV-STATCOM and System II has one 100-MW PV-STATCOM and another 100-MW PV-STATCOM or 100-MW wind farm controlled as STATCOM. Three different types of STATCOM controls are proposed for the PV solar DG and inverter-based wind DG. These are pure voltage control, pure damping control, and a combination of voltage control and damping control. The following conclusions are made: 1) In study system I, the power transfer can be increased by 168 MW during nighttime and by 142 MW in daytime even when the solar DG is generating a high amount of real power.

2) In Study System II, the transmission capacity in the night can be increased substantially by 229 MW if no DG is producing real power. During nighttime and daytime, the power transfer can be increased substantially by 200 MW, even when the DGs are generating high real power. This study thus makes a strong case for relaxing the present grid codes to allow selected inverter-based renewable generators (solar and wind) to exercise damping control, thereby increasing much needed power transmission capability. Such novel controls on PV solar DGs (and inverter-based wind DGs) will potentially reduce the need for investments in additional expensive devices, such as series/shunt capacitors and FACTS. The PV-STATCOM operation opens up a new opportunity for PV solar DGs to earn revenues in the nighttime and daytime in addition to that from the sale of real power during the day. This will, of course, require appropriate agreements between the regulators, network utilities, solar farm developers, and inverter manufacturers.

REFERENCES

- [1] Rajiv K. Varma, Senior Member, IEEE, Shah Arifur Rahman, Member, IEEE, and Tim Vanderheide, Member, IEEE, "New Control of PV Solar Farm as STATCOM (PV-STATCOM) for Increasing Grid Power Transmission Limits During Night and Day", IEEE TRANSACTIONS ON POWER DELIVERY, VOL. 30, NO. 2, APRIL 2015
- [2] S. A. Rahman, R. K. Varma, and W. Litzemberger, "Bibliography of FACTS applications for grid integration of wind and PV solar power systems: 1995–2010, IEEE working group report," presented at the IEEE Power Energy Soc. Gen. Meeting, Detroit, MI, USA, Jul. 2011.
- [3] Y. Xiao, Y. H. Song, C.-C. Liu, and Y. Z. Sun, "Available transfer capability enhancement using FACTS devices," IEEE Trans. Power Syst., vol. 18, no. 1, pp. 305–312, Feb. 2003.
- [4] Cross Texas Transmission, Salt fork to gray project. 2014. [Online]. Available: <http://www.crosstexas.com/SFWind.htm>
- [5] R. K. Varma, V. Khadkikar, and R. Seethapathy, "Nighttime application of PV solar farm as STATCOM to regulate grid voltage," IEEE Trans. Energy Convers., vol. 24, no. 4, pp. 983–985, Dec. 2009.
- [6] R. K. Varma and V. Khadkikar, "Utilization of solar farm inverter as STATCOM," U.S. Provisional Patent, Sep. 15, 2009.
- [7] R. K. Varma, S. A. Rahman, and R. Seethapathy, "Novel control of grid connected photovoltaic (PV) solar farm for improving transient stability and transmission limits both during night and day," in Proc. World Energy Conf., Montreal, QC, Canada, 2010, pp. 1–6.
- [8] R. A. Walling and K. Clark, "Grid support functions implemented in utility-scale PV systems," in Proc. IEEE

Power Energy Soc, Transm. Distrib. Conf. Expo., 2010, pp. 1–5.

[9] F. L. Albuquerque, A. J. Moraes, G. C. Guimaraes, S. M. R. Sanhueza, and A. R. Vaz, “Photovoltaic solar system connected to the electric power grid operating as active power generator and reactive power compensator,” *Solar Energy*, vol. 84, no. 7, pp. 1310–1317, Jul. 2010.

[10] A. Beekmann, J. Marques, E. Quitmann, and S. Wachtel, “Wind energy converters with FACTS Capabilities for optimized integration of wind power into trans. and dist. systems,” in *Proc. CIGRE*, Calgary, AB, Canada, 2009.

[11] S. A. Rahman and R. K. Varma, “PSCAD/EMTDC model of a 3-phase grid connected photovoltaic solar system,” in *Proc. 43rd North Amer. Power Symp.*, Boston, MA, USA, 2011, pp. 1–5.

[12] K. H. Hussein, I. Muta, T. Hoshino, and M. Osakada, “Maximum photovoltaic power tracking: an algorithm for rapidly changing atmospheric conditions,” *Proc. Inst. Elect. Eng., Gen., Transm. Distrib.*, vol. 142, no. 1, pp. 59–64, Jan. 1995.

[13] K. Chatterjee, B. G. Fernandes, and G. K. Dubey, “An instantaneous reactive volt–ampere compensator and harmonic suppressor system,” *IEEE Trans. Power Electron.*, vol. 14, no. 2, pp. 381–392, Mar. 1999.

Author Details



G. Srinivasarao

Associate Professor

Department of Electrical and Electronics Engineering,
MITK, Khammam, T.S - 507163, India.

Srinug221@gmail.com