

Design and Implementation of LTE for Efficient Operations

M.N.Meenakshi

M.Tech VLSI,
Department of ECE,
CMR Institute of Technology.

P.Navitha

Assistant Professor,
Department of ECE,
CMR Institute of Technology.

Chandra Mohan.D

Assistant Professor,
Department of ECE,
CMR Institute of Technology.

Abstract:

Focuses on Design and Implementation of Long Term Evolution (LTE) front end modules to synchronize time and frequency with the help of Fast Fourier Transform (FFT). LTE is an emerging standard for high-speed wireless communications. The synchronizer proves to have an outstanding performance with less delay time with simple circuitry for all defined communication modes in LTE.

Existing Method:

Synchronizer is used when two systems operate in different frequencies. As a design FFT works on parallel data and inputs will be in terms of serial-data. Therefore we need to convert serial data into parallel data to the input of FFT. External Input frequency, design input frequency and output frequency are synchronized by using reset, preset and enables. If frequency variation is high, it really makes complex to design with SIPO and PISO.

Proposed System:

In this system, we proposed to use FIFO based synchronizer for LTE network. In this design FFT works on post-FIFO data and inputs will be in terms of pre-FIFO data. There is no essential for converting the input data frequency into the other form of data to the input of FFT. External Input frequency, design input frequency and output frequency are synchronized by using pre-clock, clock and post-clock. If variation is high, it will be possible by using pre-FIFO and post-FIFO. The following difficulties are attempted to be addressed during this project work:

- Reducing circuit complexity.
- Replacing the SIPO/PISO Synchronizer modules with FIFO Synchronizer.
- Design of modules like FIFO synchronizer that generates necessary timing needed for interfacing to FFT.

-Reducing the of delay data processing.

Keywords: LTE, Synchronizer, SIPO, PISO, FFT, FIFO

I. INTRODUCTION:

1.1 An Introduction to LTE:

Mobile broadband is becoming a reality as Internet generation accustomed to access broadband wherever they go, mobile broadband, instead of only at home and in the office, has become a reality. Therefore, the Global System for Mobile Communications family constantly develops new mobile technologies to achieve better performance, such as higher speed, larger capacity and so forth. LTE is a step beyond 3G and towards the 4G Evolution. The contributions of LTE make sure that the users are able to request more mobile applications like interactive TV, mobile video blogging, advanced games or professional services.

Long Term Evolution (LTE) is a significant project of 3rd Generation Partnership Project (3GPP), initially proposed on the Toronto conference of 3GPP in 2004 and officially started as LTE work item in 2006. LTE, as a transition from the 3rd generation (3G) to the 4th generation (4G), has achieved great capacity and high speed of mobile telephone networks without doubt. In addition, it is combined with top-of-the-line radio techniques in order to gain better performance than Code Division Multiple Access (CDMA) approaches. LTE provides scalable carrier bandwidths from 1.4 MHz to 20 MHz and frequency division duplexing (FDD), as well as time division duplexing (TDD). LTE is composed of many new technologies compared with the previous generation of cellular systems. These new technologies are

1.OFDM (Orthogonal Frequency Division Multiplex: In order to gain high data bandwidth when transmitting packets, LTE integrates OFDM technology which can provide high-degree resilience to reflections and interference at the same time.

2.MIMO (Multiple Input Multiple Output): MIMO operations include spatial multiplexing as well as pre-coding and transmit diversity. These operations addressed the problems of multiple signals arising from many reflections, which were encountered by previous telecommunications systems.

1.2 An Introduction to Synchronizer:

Synchronizer is used when two designs operate in different frequencies. The synchronizer allows the transfer of wide vectors across clock domain with minimal timing requirements and no meta-stability issues. This block ensures that there is no metastability for a target MTBF i.e., Mean Time between Failures.

How do I synchronize the system?

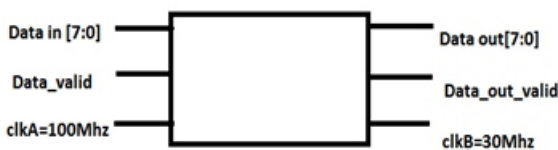

Figure 1: Example for simple synchronizer

General Definition: process of precisely coordinating or matching two or more activities, devices, or processes in time
 Computing Definition: process of making two or more data storage devices or programs (in same or different computers) having exactly the same information at a given time. Asynchronous signals are those that run from different clocks or at a different transition rate.

II. EXISTING SYNCHRONIZER METHOD:

In this system a design FFT works on parallel data and inputs will come in terms of serial-data. Therefore we need to convert serial data into parallel data to the input of FFT. Input frequency, design input frequency and output frequency are synchronized by using reset, preset and enables. If variation will be high, it is not possible to do using SIPO and PISO.

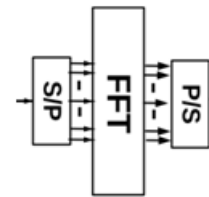

Figure 2: Existing synchronizer using Serial-In-Parallel-Out and Parallel-in-Serial-out

This design is having certain limitations. They are

- Frequency variation is high, it is not possible to process data.
- Complex circuitry.
- Delay will be high.

1.1 Serial-in to Parallel-out (SIPO) Shift Register:

The operation is as follows. Let's assume that all the flip-flops (FFA to FFD) have just been RESET (CLEAR input) and that all the outputs QA to QD are at logic level "0" i.e., no parallel data output. If a logic "1" is connected to the DATA input pin of FFA then on the first clock pulse the output of FFA and therefore the resulting QA will be set HIGH to logic "1" with all the other outputs still remaining LOW at logic "0". Assume now that the DATA input pin of FFA has returned LOW again to logic "0" giving us one data pulse or 0-1-0-0.

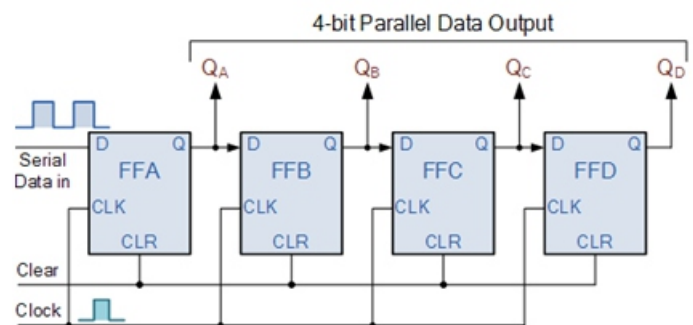
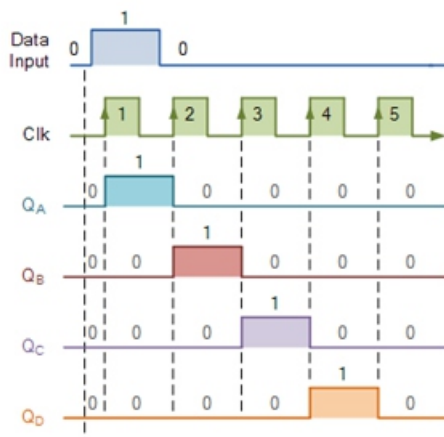

Figure 3: Serial-in Parallel Out

The second clock pulse will change the output of FFA to logic "0" and the output of FFB and QB HIGH to logic "1" as its input D has the logic "1" level on it from QA. The logic "1" has now moved or been "shifted" one place along the register to the right as it is now at QA. When the third clock pulse arrives this logic "1" value moves

to the output of FFC (QC) and so on until the arrival of the fifth clock pulse which sets all the outputs QA to QD back again to logic level “0” because the input to FFA has remained constant at logic level “0”.The effect of each clock pulse is to shift the data contents of each stage one place to the right, and this is shown in the following table until the complete data value of 0-0-0-1 is stored in the register. This data value can now be read directly from the outputs of QAto QD.Then the data has been converted from a serial data input signal to a parallel data output. The truth table and following waveforms show the propagation of the logic “1” through the register from left to right as follows.

Clock Pulse No	QA	QB	QC	QD
0	0	0	0	0
1	1	0	0	0
2	0	1	0	0
3	0	0	1	0
4	0	0	0	1
5	0	0	0	0



Note that after the fourth clock pulse has ended the 4-bits of data (0-0-0-1) are stored in the register and will remain there provided clocking of the register has stopped. In practice the input data to the register may consist of various combinations of logic “1” and “0”.

1.2 Parallel-in to Serial-out (PISO) Shift Register:

The Parallel-in to Serial-out shift register acts in the opposite way to the serial-in to parallel-out one above. The data is loaded into the register in a parallel format in which all the data bits enter their inputs simultaneously, to the

parallel input pins PA to PD of the register. The data is then read out sequentially in the normal shift-right mode from the register at Q representing the data present at PA to PD.This data is outputted one bit at a time on each clock cycle in a serial format. It is important to note that with this type of data register a clock pulse is not required to parallel load the register as it is already present, but four clock pulses are required to unload the data.

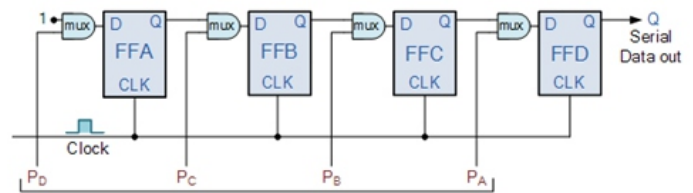

Figure 4: Parallel-in Serial Out

As this type of shift register converts parallel data, such as an 8-bit data word into serial format, it can be used to multiplex many different input lines into a single serial DATA stream which can be sent directly to a computer or transmitted over a communications line.

III.PROPOSED SYNCHRONIZER METHOD:

In this system, we proposed to use FIFO based synchronizer for LTE network. In this design FFT works on post-FIFO data and inputs will be in terms of pre-FIFO data. There is no essential for converting the input data frequency into the other form of data to the input of FFT. External Input frequency, design input frequency and output frequency are synchronized by using pre-clock, clock and post-clock. If variation is high, it will be possible by using pre-FIFO and post-FIFO.

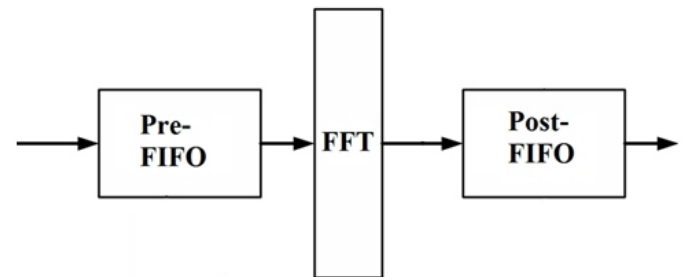

Figure 5: Proposed synchronizer using Pre-FIFO and POST-FIFO

The following difficulties are attempted to be addressed during this project work:

- Reducing circuit complexity.
- Replacing the SIPO/PISO Synchronizer modules with FIFO Synchronizer.
- Design of modules like FIFO synchronizer that generates necessary timing needed for interfacing to FFT.
- Reducing the of delay data processing.

Fist in First Out:

FIFOs are commonly used in electronic circuits for buffering and flow control between hardware and software. In its hardware form, a FIFO primarily consists of a set of read and write pointers, storage and control logic. Storage may be SRAM, flip-flops, latches or any other suitable form of storage. For FIFOs of non-trivial size, a dual-port SRAM is usually used, where one port is dedicated to writing and the other to reading.

A synchronous FIFO is a FIFO where the same clock is used for both reading and writing. An asynchronous FIFO uses different clocks for reading and writing. Asynchronous FIFOs introduce metastability issues. A common implementation of an asynchronous FIFO uses a Gray code (or any unit distance code) for the read and write pointers to ensure reliable flag generation. One further note concerning flag generation is that one must necessarily use pointer arithmetic to generate flags for asynchronous FIFO implementations. Conversely, one may use either a “leaky bucket” approach or pointer arithmetic to generate flags in synchronous FIFO implementations.

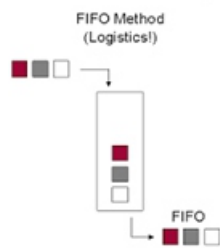

First-In, First-Out (FIFO) is one of the methods commonly used to calculate the value of inventory on hand at the end of an accounting period and the cost of goods sold during the period. This method assumes that inventory purchased or manufactured first is sold first and newer inventory remains unsold. Thus cost of older inventory is assigned to cost of goods sold and that of newer inventory is assigned to ending inventory. The actual flow of inventory may not exactly match the first-in, first-out pattern.

The proposed architecture is shown in Fig where the main steps of synchronization in LTE are implemented. In the pre-FFT blocks, coarse time and frequency synchronization is performed where the symbol timing is detected, CP type is recognized and fractional CFO is estimated and compensated in a loop with an adaptive coefficient (at). This loop consists of a first-order filter, sine and cosine estimator, and a complex multiplier. As the coarse time synchronization finishes, the CP length and the CP location are known and the CP could be easily removed. Therefore, symbols can pass through the FFT block to enter the post-FFT domain.

III. IMPLEMENTATION RESULTS:

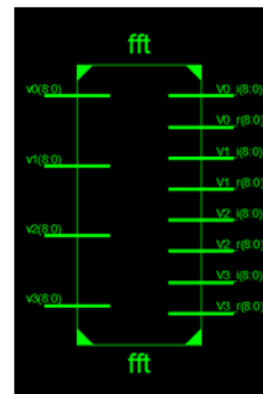

Figure 6: Block Diagram for FFT

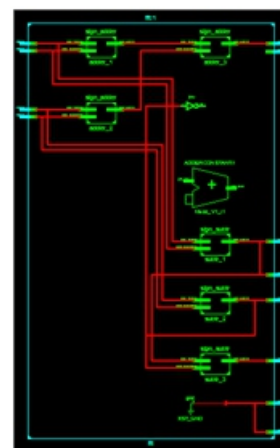

Figure 7: RTL Schematic for FFT

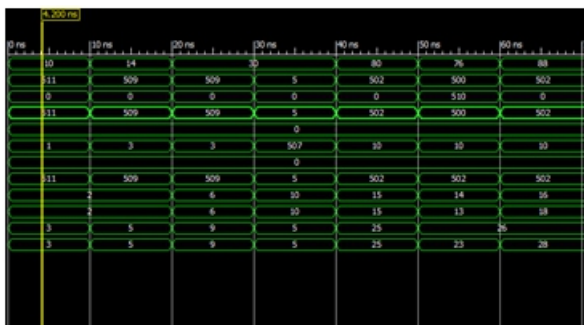

Figure 8: Simulation for FFT

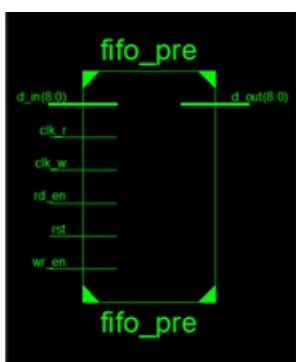

Figure 9: Block Diagram for Pre-FIFO

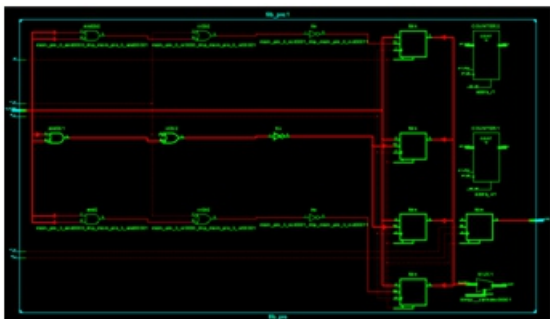

Figure 10: RTL Schematic for Pre-FIFO

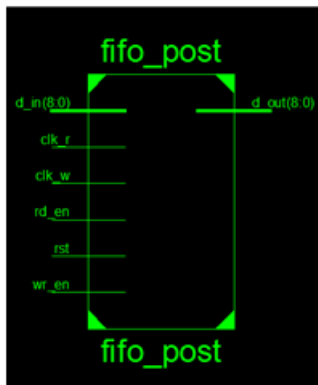

Figure 11: Block Diagram for Post-FIFO

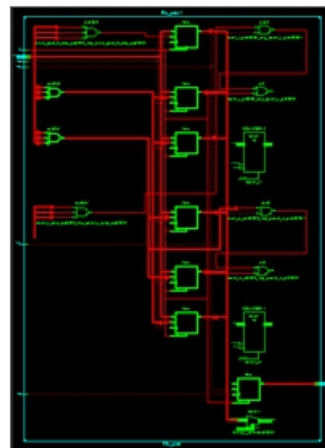

Figure 12: RTL Schematic for Post-FIFO

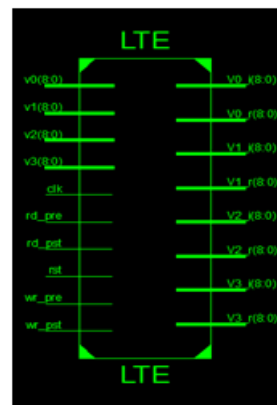

Figure 13: Block Diagram for LTE

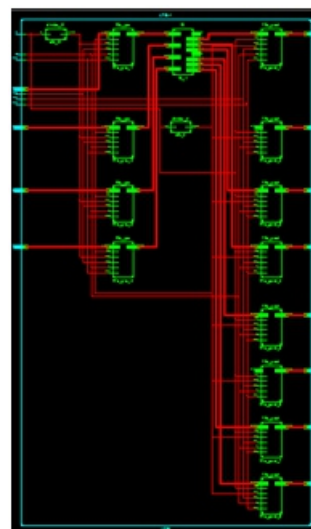

Figure 14: RTL Schematic for LTE

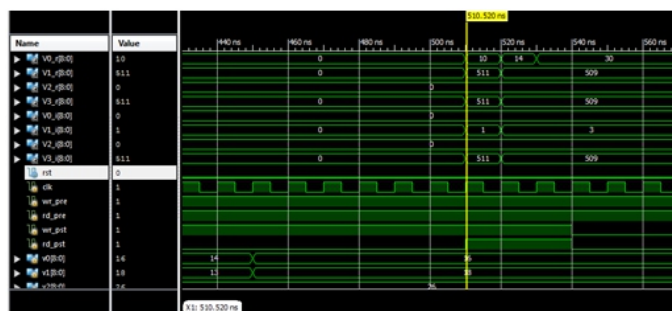

Figure 15: Simulation for LTE

IV. PARAMETRIC ANALYSIS:

Table-Delay comparisons for FFT and LTE Synchronizer:

SYNCHRONIZER	DELAY
FFT Synchronizer	11.491 ns
LTE Synchronizer	11.176 ns

Area Report for FFT Synchronizer

Device Utilization Summary (estimated values)			
Logic Utilization	Used	Available	Utilization
Number of Slices	137	768	17%
Number of Slice Flip Flops	163	1536	10%
Number of 4 input LUTs	225	1536	14%
Number of bonded IOBs	22	124	17%
Number of GCLKs	1	8	12%

Area Report for LTE Synchronizer

Device Utilization Summary (estimated values)			
Logic Utilization	Used	Available	Utilization
Number of Slices	522	768	67%
Number of Slice Flip Flops	614	1536	39%
Number of 4 input LUTs	565	1536	36%
Number of bonded IOBs	114	124	91%
Number of GCLKs	3	8	37%

V. CONCLUSION:

In this technical era, high speed data transfer over short distances plays a vital role. In order to couple speed with accuracy and economy, we opt for serial data communication. To interface a device with serial data lines, the data must be converted to and from serial format. These Synchronizers can be operated in the synchronous mode. Which is having some delay due to circuit complexity. In the communication system, there are many devices which operate at different speeds in asynchronous mode. In order to facilitate the data exchange between these asynchronous devices there is a need for an effective Synchronizer. FIFO synchronizer is one such synchronizer device in the asynchronous mode that helps in achieving error free data transmission. Targeted application of High performance with less delay has been achieved. Operates at double the speed. Keeping in view these advantages, in this paper, the FIFO synchronizer has been designed using Verilog and implemented on FPGA kit.

REFERENCES:

- [1] Technical Specification Group Radio Access Network; Requirements for Further Advancements for Evolved Universal Terrestrial Radio Access (E-UTRA) (LTE-Advanced) (Release 9), 3GPP TR 36.913 V9.0.0, Dec. 2009.
- [2] P.-Y. Tsai and H.-W. Chang, "A new cell search scheme in 3GPP long term evolution downlink, OFDMA systems," in Proc. IEEE WCSP, Nov. 2009, pp. 1–5.
- [3] K. Manolakis, D. M. Gutierrez Estevez, V. Jungnickel, W. Xu, and C. Drewes, "A closed concept for synchronization and cell search in 3GPP LTE systems," in Proc. IEEE WCNC, Apr. 2009, pp. 1–6.
- [4] M. J. Shim, J. S. Han, H. J. Roh, and H. J. Choi, "A frequency synchronization method for 3GPP LTE OFDMA system in TDD mode," in Proc. 9th IEEE ISCT, Sep. 2009, pp. 864–868.
- [5] C.-C. Lee, C.-F. Liao, C.-M. Chen, and Y.-H. Huang, "Design of 4×4 MIMO-OFDMA receiver with precoding codebook search for 3GPP-LTE," in Proc. IEEE ISCAS, May/Jun. 2010, pp. 3957–3960.
- [6] C.-W. Chu, C.-C. Lee, and Y.-H. Huang, "Design of an OFDMA baseband receiver for 3GPP long-term evolution," in Proc. IEEE VLSI-DAT, Apr. 2008, pp. 196–199.
- [7] N. Ding, C. Chen, W. Fan, Y. Chen, and X. Zeng, "An improved coarse synchronization scheme in 3GPP LTE downlink OFDM systems," in Proc. IEEE ISCAS, May 2012, pp. 1516–1519.
- [8] W. Xu and K. Manolakis, "Robust synchronization for 3GPP LTE system," in Proc. IEEE GLOBECOM, Dec. 2010, pp. 1–5.
- [9] I. Diaz, L. Wilhelmsson, J. Rodrigues, J. Lofgren, T. Olsson, and V. Öwall, "A sign-bit auto-correlation architecture for fractional frequency offset estimation in OFDM," in Proc. IEEE ISCAS, May/Jun. 2010, pp. 3765–3768.
- [10] Y. Kim and K. Chang, "Complexity optimized CP length pre-decision metric for cell searcher in the downlink of 3GPP LTE system," in Proc. IEEE 20th Personal, Indoor Mobile Radio Commun., Sep. 2009, pp. 895–899.
- [11] J. I. Mazarico, V. Capdevielle, A. Feki, and V. Kumar, "Detection of synchronization signals in reuse-1 LTE networks," in Proc. 2nd IEEE WD, Dec. 2009, pp. 1–5.
- [12] Y.-C. Lin, S.-L. Su, and Y.-J. Fan, "Joint sector ID and ICFO detection by using partial correlation scheme in LTE cell search process," *Wireless Personal Commun.*, vol. 70, no. 4, pp. 1603–1621, 2013.
- [13] C. Ma, H. Cao, and P. Lin, "A low-power low-cost design of primary synchronization signal detection," *IEEE Trans. Very Large Scale Integr. (VLSI) Syst.*, vol. 20, no. 7, pp. 1161–1166, Jul. 2012.
- [14] A. Golnari, G. Sharifan, Y. Amini, and M. Shabany, "A low complexity architecture for the cell search applied to the LTE systems," in Proc. 19th IEEE ICECS, Dec. 2012, pp. 300–303.
- [15] B. M. Popovic, "Generalized chirp-like polyphase sequences with optimum correlation properties," *IEEE Trans. Inf. Theory*, vol. 38, no. 4, pp. 1406–1409, Jul. 1992.
- [16] F. Wang, Y. Zhu, and Z. Wang, "A low complexity scheme for S-SCH detection in 3GPP LTE downlink system," in Proc. IEEE GMC, Oct. 2010, pp. 1–6.
- [17] M. Speth, S. A. Fechtel, G. Fock, and H. Meyr, "Optimum receiver design for wireless broad-band systems using OFDM. I," *IEEE Trans. Commun.*, vol. 47, no. 11, pp. 1668–1677, Nov. 1999.
- [18] J. González-Bayón, C. Carreras, and A. Fernández-Herrero, "Comparative evaluation of carrier frequency offset tracking schemes for WiMAX OFDM systems," in Proc. IEEE ISSPIT, Dec. 2007, pp. 479–484.