

A Seven Level Single-Phase Cascaded Inverter with Improved Efficiency

**Kadasu Venu**

M.Tech Student,

Department of EPID,

Sindhura College of Engineering & Technology.

**U. Krishna Prasad**

Associate Professor,

Dept of EEE,

Sindhura College of Engineering & Technology.

Abstract:

In this paper, a single-phase multilevel inverter with battery balancing is proposed. The voltage source inverters produce a voltage with levels either 0 or $\pm V_{dc}$; they are known as two level inverters. To obtain a quality output voltage or a current waveform with a minimum amount of ripple content, they require high switching frequency along with various pulse width modulation (PWM) strategies. As the number of voltage levels increases, the harmonic content of output voltage waveform decreases significantly. Battery systems are affected by many factors, a key one being the cells unbalancing. Without the balancing system, the individual cell voltages will differ over time, battery pack capacity will decrease quickly.

That will result in the failure of the total battery system. Thus cell balancing acts an important role on the battery life preserving. Different cell balancing methodologies have been proposed for battery pack. In this paper, the general structure of multi-level converter is to synthesize a near sinusoidal voltage from several levels of dc voltages. The operational principle of the proposed system is first described, and then, the design equation is derived. Simulation results are obtained for single phase 9-level inverter with battery balancing with MATLAB/Simulink.

Keywords:

Inverter, PWM, Battery pack capacity, Harmonic.

INTRODUCTION:

Now a day because of increased energy consumption, the demand of energy is abnormally increased. So the usages of renewable energy sources have taken a lead role. Renewable energy is derived from natural processes that are replenished constantly. In its various forms, it derives directly from the sun, or from heat generated deep within the earth. Included in the definition is electricity and heat generated from solar, wind, ocean, hydropower, biomass, geothermal resources, and biofuels and hydrogen derived from renewable resources. Interconnecting these periodic sources to the utility grid on a large scale could affect the voltage/frequency control of the grid and lead to severe power quality issues [1]–[6].

Large capacity of battery storage system is essential to store these energy. To obtain better battery storage performances, many battery charging strategies have been presented [7]. In order to reduce energy loss in transmission lines and increase the overall battery capacity, the battery bank is series connected for a high-voltage dc power supply [1], [2], [7]. Therefore, the power conversion system requires a battery-balancing circuit, as shown in Figure. 1, to adjust each battery voltage to be equal.

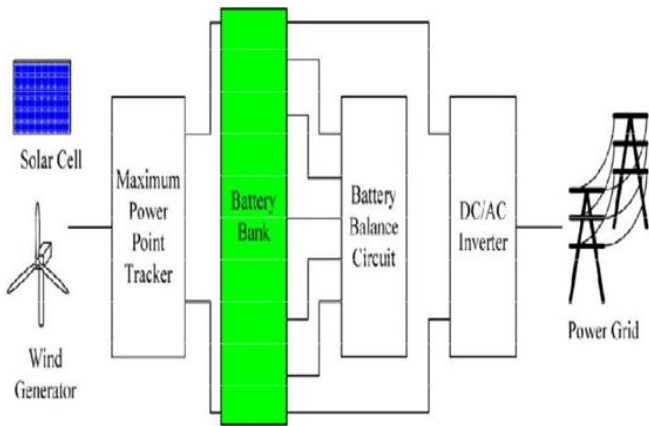

Figure. 1. Renewable energy systems.

In this paper, the general structure of multi-level converter is to synthesize a near sinusoidal voltage from several levels of dc voltages. The operational principle of the proposed system is described, and then, the design equation is derived.

II. MULTILEVEL INVERTER:

An inverter is an electrical device that converts direct current (DC) to alternating current (AC); the converted AC can be at any required voltage and frequency with the use of appropriate transformers, switching, and control circuits. Static inverters have no moving parts and are used in a wide range of applications, from small switching power supplies in computers, to large electric utility high-voltage direct current applications that transport bulk power. Inverters are commonly used to supply AC power from DC sources such as solar panels or batteries. The electrical inverter is a high-power electronic oscillator. It is so named because early mechanical AC to DC converters was made to work in reverse, and thus were "inverted", to convert DC to AC. The inverter performs the opposite function of a rectifier

A. Cascaded H-Bridges Inverter:

A single-phase structure of an m-level cascaded inverter is illustrated in Figure2 Each separate dc source (SDCS) is connected to a single-phase full-bridge, or Hbridge, inverter. Each inverter level can generate three different voltage outputs, +Vdc, 0, and -Vdc by connecting the dc source to the ac output by

different combinations of the four switches, S1, S2, S3, and S4. To obtain +Vdc, switches S1 and S4 are turned on, whereas -Vdc can be obtained by turning on switches S2 and S3. By turning on S1 and S2 or S3 and S4, the output voltage is 0. The ac outputs of each of the different full-bridge inverter levels are connected in series such that the synthesized voltage waveform is the sum of the inverter outputs. The number of output phase voltage levels m in a cascade inverter is defined by $m = 2s + 1$, where s is the number of separate dc sources. An example phase voltage waveform for an 11-level cascaded H-bridge inverter with 5 SDCSs and 5 full bridges is shown in Figure 2 The phase voltage $v_{an} = v_{a1} + v_{a2} + v_{a3} + v_{a4} + v_{a5}$.

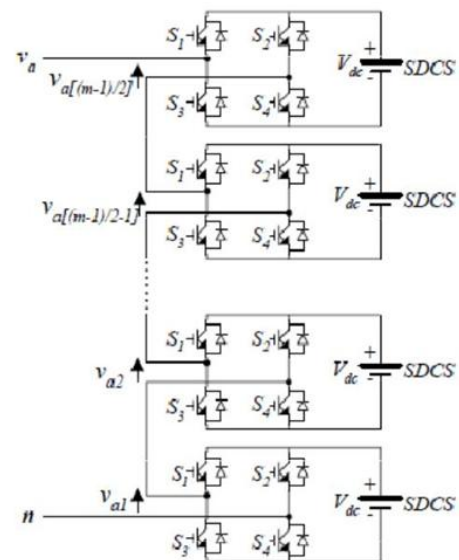

Figure.2 Single-phase structure of a multilevel cascaded H-bridges inverter

For a stepped waveform such as the one depicted in Figure.3 with s steps, the Fourier Transform for this waveform follows $() = [\cos() + \cos() + \dots + \cos()]$, where $n = 1, 3, 5, 7$

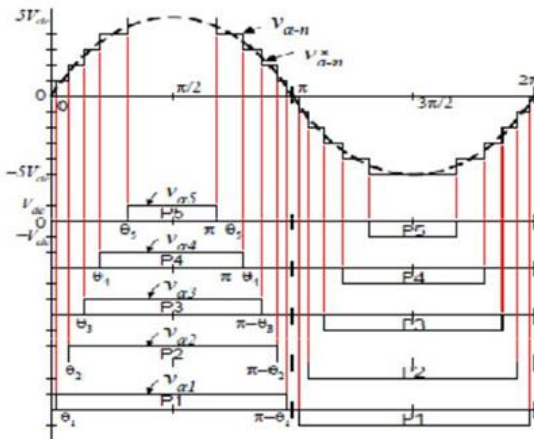

Figure 3. Output phase voltage waveform of an 11-level cascade inverter with 5 separate dc sources

The conducting angles, $\theta_1, \theta_2, \dots, \theta_s$, can be chosen such that the voltage total harmonic distortion is a minimum. Generally, these angles are chosen so that predominant lower frequency harmonics, 5th, 7th, 11th, and 13th, harmonics are eliminated. More detail on harmonic elimination techniques will be presented in the next section. Multilevel cascaded inverters have been proposed for such applications as static var generation, an interface with renewable energy sources, and for battery-based applications. Three-phase cascaded inverters can be connected in wye, as shown in Figure 4, or in delta.

Peng has demonstrated a prototype multilevel cascaded static var generator connected in parallel with the electrical system that could supply or draw reactive current from an electrical system. The inverter could be controlled to either regulate the power factor of the current drawn from the source or the bus voltage of the electrical system where the inverter was connected. Peng and Joos have also shown that a cascade inverter can be directly connected in series with the electrical system for static var compensation. Cascaded inverters are ideal for connecting renewable energy sources with an ac grid, because of the need for separate dc sources, which is the case in applications such as photovoltaic's or fuel cells.

Cascaded inverters have also been proposed for use as the main traction drive in electric vehicles, where several batteries or ultra capacitors are well suited to serve as SDCSs. The cascaded inverter could also serve as a rectifier/charger for the batteries of an electric vehicle while the vehicle was connected to an ac supply as shown in Figure. Additionally, the cascade inverter can act as a rectifier in a vehicle that uses regenerative braking

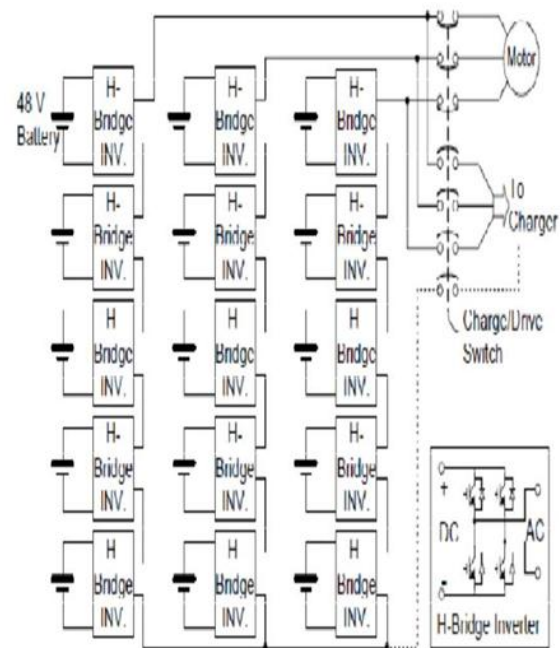

Figure 4. Three-phase wye-connection structure for electric vehicle motor drive and battery charging.

B. Phase Shifted Carrier PWM (PSCPWM)

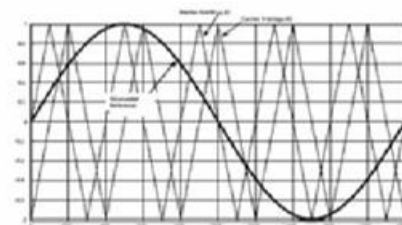

Figure 5. Phase Shifted Carrier PWM

Figure-5 shows the Phase shifted carrier pulse width modulation.

Each cell is modulated independently using sinusoidal unipolar pulse width modulation and bipolar pulse width modulation respectively, providing an even power distribution among the cells. A carrier phase shift of 180° (No. of levels) for cascaded inverter 1S introduced across the cells to generate the stepped multi level output waveform with lower distortion.

C. Level Shifted Carrier PWM (LSCPWM)

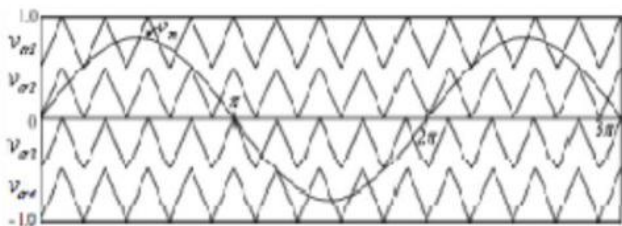

Figure 6. Level Shifted Carrier PWM

Figure-6 shows the Level shifted carrier pulse width modulation. Each cell is modulated independently using sinusoidal uni polar width modulation and bipolar pulse width modulation respectively, providing an even power distribution among the cells. A carrier Level shift by 180° (No. of levels) for cascaded inverter 1S introduced across the cells to generate the stepped multilevel output waveform with lower distortion.

III.SYSTEM DESCRIPTION:

Among topologies of multilevel inverters, the cascaded multilevel inverter with separate dc sources is superior to the other multilevel structures in terms of its structure which is simple and modular. This modular structure makes it easily extensible for a higher number of output voltage levels without increasing in the power circuit complexity [3], [4]. In this paper, the characteristics of a cascaded multilevel inverter are achieved. In addition, the battery-balancing function is implemented. Figure 7 shows the conventional $2N + 1$ -level multilevel inverter composed of N individual full-bridge inverters and N batteries. The set of the batteries can be defined as

$$B = \{B_1, B_2, \dots, B_n, \dots, B_N\}.(1)$$

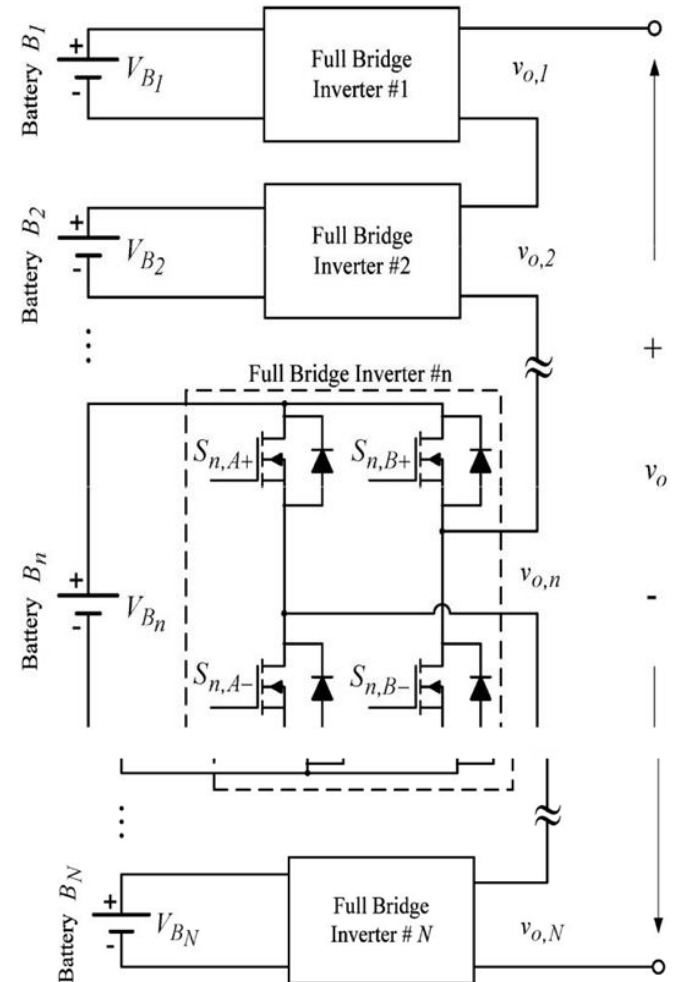

Output Voltage $v_{o,n}$	Switches State
$+V_{B_n}$	ON: $S_{n,B+}, S_{n,A-}$ & OFF: $S_{n,A+}, S_{n,B-}$
0	ON: $S_{n,A+}, S_{n,B+}$ & OFF: $S_{n,A-}, S_{n,B-}$ or ON: $S_{n,A-}, S_{n,B-}$ & OFF: $S_{n,A+}, S_{n,B+}$
$-V_{B_n}$	ON: $S_{n,A+}, S_{n,B-}$ & OFF: $S_{n,B+}, S_{n,A-}$

Table I. Relationships of the Output Voltages of Individual Full-Bridge Inverters And Their Switch States

Each individual full-bridge inverter has a separate battery source B_n . Thus, the individual full-bridge inverter can provide three different voltage outputs $+VB_n$, 0 , and $-VB_n$ by different combinations of the four switches $S_{n,A+}$, $S_{n,A-}$, $S_{n,B+}$, and $S_{n,B-}$ as shown in Table I. The output voltage v_o of the multilevel inverter is equal to the sum of the voltages of the individual full-bridge inverters, shown as

$$v_o = \sum_{n=1}^N V_{bn} \quad (2)$$

where V_{bn} is the voltage of battery B_n . The set of the batteries providing the output voltage in the multilevel inverter can be defined as $B_{sel} = \{B_1, B_2, \dots, B_n, \dots, B_M\}$, $M \leq N$. (3)

Clearly, a sine wave can be generated by programming a suitable sequence with a positive/negative polarity control. If the characteristics of all of the batteries are equal, the switching pattern-swapping scheme can be adopted to achieve battery balancing [34]. Unfortunately, any two batteries are different. In order to solve this problem, this paper proposes a new battery-balancing method for a Cascaded multilevel inverter. First, the battery set B is sorted, and the sorted battery set B_{sort} can be shown as.

$$B_{sort} = \{B^*1, B^*2, \dots, B^*H, \dots, B^*N\} \quad (4)$$

in which the relation of battery voltages is $VB^*n \leq VB^*(n-1)$, $n=1, 2, \dots, N$. This means that the battery with the highest voltage is denoted as B^*1 , the battery with the second highest voltage is denoted as B^*2 , and the battery with the lowest voltage is denoted as B^*N . Using the Fourier series analysis, the root-mean-square (rms) voltage and the h th harmonic $H(h)$ of the quasi-sinusoidal wave can be expressed as [8]-[10].

$$V_{h,rms} = \alpha \beta^*1, \alpha \beta^*2, \dots, \alpha \beta^*N$$

$$= \sqrt{42h\pi} \sum_{n=1}^N VB^*n \cosh \alpha n + \dots + VB^*1 \cosh \alpha N, \text{ where } h = 1, 3, 5, 7$$

According to (5), the switching angles can be found such that the THD is minimized and the rms of the fundamental frequency is close to the reference voltage V_{1,rms_ref} . After that, M batteries for output voltage are decided according to the switching angles. Finally, these M batteries with higher voltage are chosen and shown as

$$B_M = \{B^*1, B^*2, \dots, B^*M\} \quad (6)$$

The output voltage of the multilevel inverter can be expressed as

$$v_o = \sum_{i=1}^M VB^*i = VB^*1 + VB^*2 + \dots + VB^*M. \quad (7)$$

As shown in Fig.7, a quasi-sinusoidal wave can be generated. Assume that the load current I_L is constant during a half-cycle of a sinusoidal wave; the discharge capacities Q_{Bn} of battery B_n can be expressed as

$$Q_{Bn} = I_L \cdot (\pi - 2\theta_n) \quad (8)$$

where θ_n is the n th switch angle and $\theta_n < \theta_{n+1}$. Clearly, the discharging capacity of a battery with higher voltage is greater than that of a battery with lower voltage. Thus, where θ_n is the n th switch angle and $\theta_n \leq \theta_{n+1}$. Clearly, the discharging capacity of a battery with higher voltage is greater than that of a battery with lower voltage. Thus, the battery balancing function is achieved.

IV. SIMULATION RESULTS:

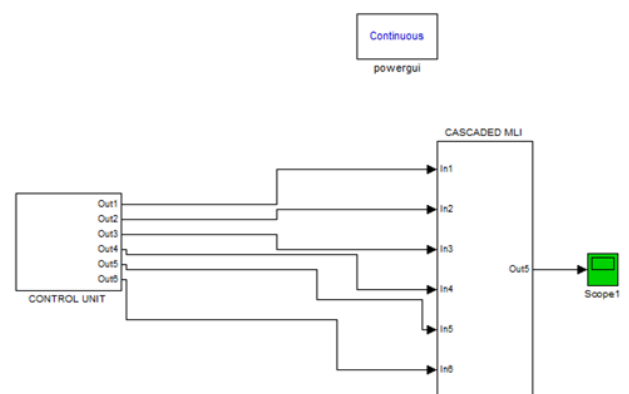

Figure 8. Simulink model of Battery balancing with 7-level inverter

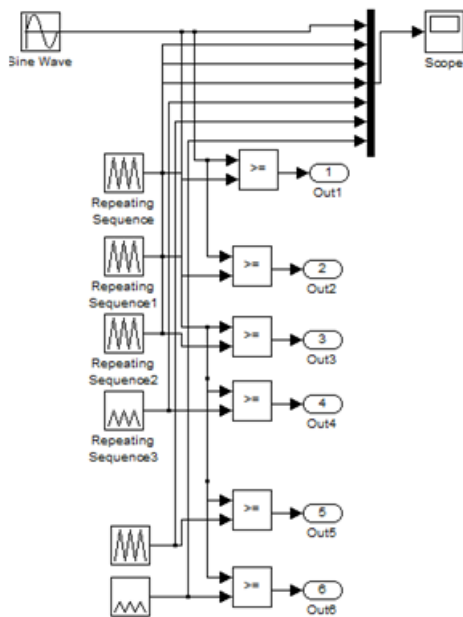

Figure 9. smulink model of control circuit

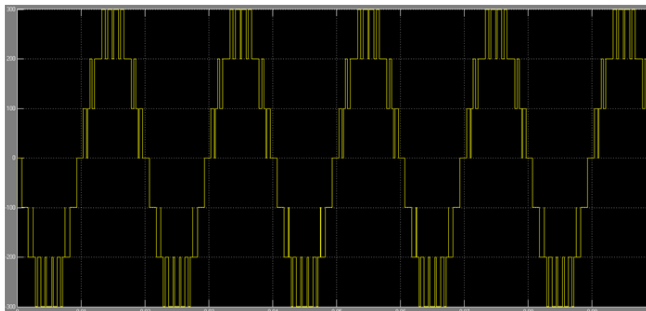

Figure10. Output voltage 7-level inverter

IV. CONCLUSION:

In this paper, a single-phase 9-level inverter with battery balancing has been proposed and proved successful. The input of each individual inverter is directly connected to a Battery. The combination of batteries can be controlled according to the batteries' voltages to implement the battery-balancing. Additionally, the switch angle is controlled to contain the ac output voltage with minimal THD.

REFERENCES:

[1]T. Hirose and H. Matsuo, "Standalone hybrid wind-solar power generation system applying dump power control without dump load," IEEE Trans. Ind. Electron., vol. 59, no. 2, pp. 988-997, Feb. 2012.

[2]H. Kanchev, D. Lu, F. Colas, V. Lazarov, and B.Francois, "Energy management and operational planning of a microgrid with a PV-based active generator for smart grid applications," IEEE Trans. Ind. Electron., vol. 58, no. 10, pp. 4583-4592, Oct. 2012.

[3] Z. Haihua, T. Bhattacharya, T. Duong, T. S. T. Siew, and A. M. Khambadkone, "Composite energy storage system involving battery and ultracapacitor with dynamic energy management in microgrid applications," IEEE Trans. Power Electron., vol. 26, no. 3, pp. 923-930, Mar. 2011.

[4]H. Qian, J. Zhang, J. S. Lai, andW. Yu, "A high-efficiency grid-tie battery energy storage system," IEEE Trans. Power Electron., vol. 26, no. 3, pp. 886-896, Mar. 2011.

[5]S. Kouro, M. Malinowski, K. Gopakumar, J. Pou, L. G. Franquelo, B.Wu, J. Rodriguez, M. A. Pérez, and J. I. Leon, "Recent advances and industrial applications of multilevel converters," IEEE Trans. Ind. Electron., vol. 57, no. 8, pp. 2553- 2580, Aug. 2010.

[6]C. Abbey and G. Joos, "Supercapacitor energy storage for wind energy applications," IEEE Trans. Ind. Appl., vol. 43, no. 3, pp. 769-776, May/Jun. 2007.

[7]B. Y. Chen and Y. S. Lai, "New digital-controlled technique for battery charger with constant current and voltage control without current feedback," IEEE Trans. Ind. Electron., vol. 59, no. 3, pp. 1545-1553, Mar. 2012.

[8] L. R. Chen, C. M. Young, N. Y. Chu, and C. S. Liu, "Phase-locked bidirectional converter with pulse charge function for 42-V/14-V dual voltage Power Net," IEEE Trans. Ind. Electron., vol. 58, no. 5, pp. 2045- 2048, May 2011.



[9] Y. H. Liu and Y. F. Luo, "Search for an optimal rapid-charging pattern for Li-ion batteries using the Taguchi approach," *IEEE Trans. Ind. Electron.*, vol. 57, no. 12, pp. 3963–3971, Dec. 2010.

[10] L. R. Chen, "Design of duty-varied voltage pulse charger for improving 53 Li-ion battery-charging response," *IEEE Trans. Ind. Electron.*, vol. 56, no. 2, pp. 480–487, Feb. 2009.

Author's Details:

Kadasu Venu, Received my b.tech degree from Sindhura college of engg & tech Ntpc jyothinagar telagana in 2014. And currently pursuing m.tech in power industrial drives At sindhura college of engg & tech.

U.Krishna Prasad, Obtained My B.Tech (EEE) degree from SR Engineering College in 2008, M.Tech. (Power Electronics) from Vaagdevi college of Engineering in 2011. I worked as Asst. Prof. in SREE CHAITANYA INSTITUTE OF TECHNOLOGICAL SCIENCES. And I am working as an Associate Professor in dept. of EEE at Sindhura College of engineering and technological since 2014. My interest area includes power electronics and electrical machines. And I Have 5 years teaching experience.