

## MEMS Based Controlled Wheelchair System Using Raspberry-Pi with Video Monitoring

**Srilatha.Ch**

(M.Tech) Embedded Systems,  
Tudi Narsimhareddy Institute of  
Technology and Science.

**Mr.Sathish Parvatham**

Assistant Professor,  
Tudi Narsimhareddy Institute of  
Technology and Science.

**Dr.Samalla Krishna**

Professor,  
Tudi Narsimhareddy Institute of  
Technology and Science.

**Abstract:**

A novel technique is implemented for the hand controlled based independent and cost effective system. The purpose of hand movement based control electric wheelchair is to eliminate the necessity of the assistance required for the disabled person. And it provides great opportunity of the disabled to feel of independent accessible life. The implemented system will allow the disabled person to control the wheelchair without the assistance from other persons. In this system controlling of wheelchair carried out based on hand movements. The camera is mounted in front of the user to capture the video, According to the position of the hand, wheelchair motor will be directed to move left, right and forward. In addition to this, for the safety purpose ultrasonic sensor is mounted in front of wheelchair to detect the obstacles and automatically stop the wheelchair movement. To make system cost effective for monitoring, a ARM7 board allowed to access the system without displaying unit.

**Keywords:**

Raspberry Pi, AT89S52 controller, MEMS technology, Ultrasonic sensor, USB camera, DC motors.

**I.INTRODUCTION:**

The Wheelchair is dependent system used by elderly and physical disable persons. Here introducing the design implementation models of totally independent handheld control electric wheelchair. As per requirement of the disabilities deferent kind of automatic systems are available in market such as voice control or joystick control system. Sometime for totally paralysis person may be have very difficult to use that type of systems.

Here the handheld control system provides the independence to make their life easy and more convenient [1]. And also they save the huge amount of energy or external man power. Camera captured the image in real time and analysis. The MEMS sensor input to set the commands for interface the motor driver IC through sending the commands to GPIO pins. The motor driver circuit is used to perform the different operation such as left, right, forward and stop. And several application and algorithms are used to find out accurate pupil location detection and tracking of that. One of them is cascade like features detection algorithm used to detects single or multiple face and detection of both eye [3]. To detecting the exact value and locate its center point is ultimate goal of this system. For automatically find out the value many computer vision library of edge detection, pattern matching etc. For handheld tracking there several number of other techniques available [4] [5]. The head movement based system has limitation, when user can not able to access the system physically [9] [10].

**II. RELATED TO WORK:**

**2.1 BLOCK DIAGRAM:**

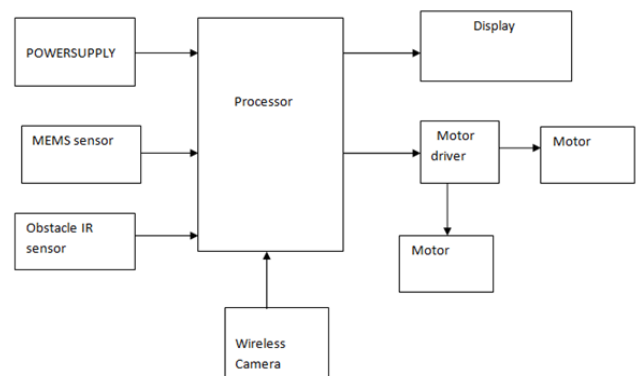

**Figure-1: Block Diagram**

**2.2 EXISTING METHOD:**

In the existing system we need a support of another person for moving from one place to another place. Time duration of another person is wasted. Video monitoring can be used for where the person is moving. To overcome project this proposed method came to an existence.

**2.3 PROPOSED METHOD:**

The proposed method is used to overcome the drawbacks present in existing method. Here we are using ARM Intelligent Monitoring Center we use MEMS sensor the direction will be changed left, right, forward and backward directions. Ultrasonic sensor is used for obstacle detection. Obstacle got detected at that moment we will get information through WIFI module. Through this method the person can move himself without help of another person.

**III.HARDWARE COMPONENTS:**

**3.1 RASPBERRY PI PROCESSOR:**



**Figure-2: Raspberry Pi diagram**

The Raspberry Pi board involves a processor and snap shots chip, Random Access Memory (RAM) and more than a few interfaces and connectors for external devices. Some of these instruments are main others are optional. It operates in the identical method as a ordinary pc, requiring a keyboard for command entry, a show unit and a vigor give.

Considering that raspberry Pi board operates like pc it requires ‘mass-storage’, but a tough disk pressure of the variety observed in a ordinary pc is not relatively in maintaining with the miniature dimension of Raspberry Pi.

**3.2. DC MOTOR:**

In any electric motor, operation is based on simple electromagnetism. A current-carrying conductor generates a magnetic field; when this is then placed in an external magnetic field, it will experience a force proportional to the current in the conductor, and to the strength of the external magnetic field. As you are well aware of from playing with magnets as a kid, opposite (North and South) polarities attract, while like polarities (North and North, South and South) repel. The internal configuration of a DC motor is designed to harness the magnetic interaction between a current-carrying conductor and an external magnetic field to generate rotational motion.

**3.3. MEMS SENSOR:**

Micro electromechanical systems (MEMS) is a process technology used to create tiny integrated devices or systems that combine mechanical and electrical components. They are fabricated using integrated circuit (IC) batch processing techniques and can range in size from a few micrometers to milli metres. These devices (or systems) have the ability to sense, control and actuate on the micro scale, and generate effects on the macro scale. In the most general form, MEMS consist of mechanical microstructures, micro sensors, micro actuators and microelectronics, all integrated onto the same silicon chip. Micro sensors detect changes in the system’s environment by measuring mechanical, thermal, magnetic, chemical or electromagnetic information or phenomena. Microelectronics process information and signal the micro actuators to react and create some form of changes to the environment.

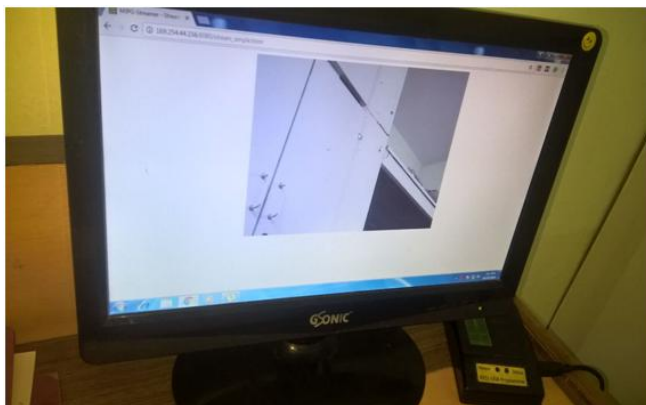

**Figure-3: MEMS sensor**

**IV. RESULTS:**



**Figure-4: Hardware Implementation**



**Figure-5: Video monitoring of robot**

**V. FUTURE SCOPE:**

- The cost of ARM11 is more that's why in future we can implement this system using ARM CORTEX A8, Beagle bone etc as well as updated processors with high frequencies will work fine.
- The concept of the mems controlled wheelchair is not only represents the alternative resources but more important to help physically disabled persons to make their life independent.

- To make the system more interact with patient we need to add some additional sensors. Delay time may be further reducing to a second. Operation of system depends on eye movement of totally paralyze patients. Thus wheelchair moves in all required direction with good response.

**VI. CONCLUSION:**

The project “MEMS BASED CONTROLLED WHEELCHAIR SYSTEM USING RASPBERRY-PI WITH VIDEO MONITORING” has been successfully designed and tested. It has been developed by integrating features of all the hardware components and software used and tested. Presence of every module has been reasoned out and placed carefully thus contributing to the best working of the unit. Secondly, using highly advanced ARM Cortex A8 Processor board and with the help of growing technology the project has been successfully implemented. Today, Robots play a vey major role in industrial applications. In future these may come in every field, they could change the way the people live. Even though robots are the creation of human, they are more efficient and accurate. In the real time application we can use long range ultrasonic for the sensing of obstacles in a little far distance and always monitor the position of wheelchair like as it bend front or back or right or left. Thus this project enables to help the physically challenged persons to move freely with their own control of the wheel chair and that is the sensor based automated wheelchair.

**VII. REFERENCES:**

[1]Wireless Medical Technologies: A Strategic Analysis of Global Markets [online]. International Telecoms Intelligence.

[2]G. Y. Jeong, K. H. Yu, and Kim. N. G. Continuous blood pressure monitoring using pulse wave transit time. In International Conference on Control, Automation and Systems (ICCAS), 2005.

[3]K. Hung, Y. T. Zhang, and B. Tai. Wearable medical devices for telehome healthcare. In Procs.



26th Annual International Conference on the IEEE  
EMBS, 2004.

[4]Fang, Xiang et al: An extensible embedded terminal  
platform for wireless telemonitoring, Information and  
Automation (ICIA), 2012 International Conference on  
Digital Object Identifier:  
10.1109/ICInfA.2012.6246761 Publication Year: 2012  
, Page(s): 668 - 673

[5]Majer, L., Stopjaková, V., Vavrinský, E.: Sensitive  
and Accurate Measurement Environment for  
Continuous Biomedical Monitoring using  
Microelectrodes. In: Measurement Science Review. -  
ISSN 1335- 8871. - Vol. 7, Section 2, No. 2 (2007), s.  
20-24.

[6]Majer, L., Stopjaková, V., Vavrinský, E.: Wireless  
Measurement System for Non-Invasive Biomedical  
Monitoring of Psycho Physiological Processes. In:  
Journal of Electrical Engineering. - ISSN 1335-3632. -  
Vol. 60, No. 2 (2009), s. 57-68.