

Design and Analysis of Aircraft Wing

Sudhir Reddy Konayapalli

M.Tech (Production Engineering & Engineering Design),
GVIC, Madanapalli.

Y. Sujatha

M.Tech (Production Engineering & Engineering Design),
GVIC, Madanapalli.

ABSTRACT

In the present study, a general aviation airplane is designed and analyzed. The design process starts with a sketch of how the airplane is envisioned. Weight is estimated based on the sketch and a chosen design mission profile. A more refined method is conducted based on calculated performance parameters to achieve a more accurate weight estimate which is used to acquire the external geometry of the airplane. A three-dimensional layout of the airplane is created using RDS software based on conic lofting, then placed in a simulation environment in Matlab which proved the designs adherence to the design goals. In addition, static stress analysis is also performed for wing design purposes. Using the finite element software package COMSOL, the calculated aerodynamic loads are applied to the wing to check the wing reliability. It is shown that the designed wing could be a good candidate for similar general aviation airplane implementation.

Keywords: Aircraft Design, Structural Analysis

1. INTRODUCTION

An aircraft is a machine that is able to fly by gaining support from the air, or, in general, the atmosphere of a planet. It counters the force of gravity by using either static lift or by using the dynamic lift of an airfoil, or in a few cases the downward thrust from jet engines. The human activity that surrounds aircraft is called aviation. Crewed aircraft are flown by an onboard pilot, but unmanned aerial vehicles may be remotely controlled or self-controlled by onboard computers. Aircraft may be classified by different criteria, such as lift type, propulsion, usage and others.



Fig 1: Qantas Airbus A380, the world's largest passenger airliner

2. DESIGN AND CONSTRUCTION

Aircraft are designed according to many factors such as customer and manufacturer demand, safety protocols and physical and economic constraints. For many types of aircraft the design process is regulated by national airworthiness authorities.

The key parts of an aircraft are generally divided into three categories:

- The structure comprises the main load-bearing elements and associated equipment.
- The propulsion system (if it is powered) comprises the power source and associated equipment, as described above.
- The avionics comprise the control, navigation and communication systems, usually electrical in nature.

Structure

The approach to structural design varies widely between different types of aircraft. Some, such as paragliders, comprise only flexible materials that act in tension and rely on aerodynamic pressure to hold their shape. A balloon similarly relies on internal gas pressure but may have a rigid basket or gondola slung below it to carry its payload. Early aircraft, including airships, often

employed flexible doped aircraft fabric covering to give a reasonably smooth aero shell stretched over a rigid frame. Later aircraft employed semi-monocoque techniques, where the skin of the aircraft is stiff enough to share much of the flight loads. In a true monocoque design there is no internal structure left. The key structural parts of an aircraft depend on what type it is.

Aerostats

Lighter-than-air types are characterized by one or more gasbags, typically with a supporting structure of flexible cables or a rigid framework called its hull. Other elements such as engines or a gondola may also be attached to the supporting structure.

Aerodynes

Heavier-than-air types are characterized by one or more wings and a central fuselage. The fuselage typically also carries a tail or empennage for stability and control, and an undercarriage for takeoff and landing. Engines may be located on the fuselage or wings. On a fixed-wing aircraft the wings are rigidly attached to the fuselage, while on a rotorcraft the wings are attached to a rotating vertical shaft. Smaller designs sometimes use flexible materials for part or all of the structure, held in place either by a rigid frame or by air pressure. The fixed parts of the structure comprise the airframe.

Avionics

The avionics comprise the flight control systems and related equipment, including the cockpit instrumentation, navigation, radar, monitoring, and communication systems.

3. PLANE COMPONENTS

Planes have a number of different components to help them fly. The wing is responsible for generating lift. The main central body of the plane is called the fuselage. This houses the cockpit, where the pilot sits. It may also contain a cabin for passengers, or a cargo bay for carrying other items. At the rear of the fuselage are the horizontal and vertical tails (or stabilisers). These help the plane to fly smoothly and stay heading in one direction. One or more engines provide thrust. These

engines may turn a propeller. Engines are usually located at the front of the fuselage, or below the wings if there are a number of them, but they can also be located at the rear of the fuselage, above the wing or in the wing.

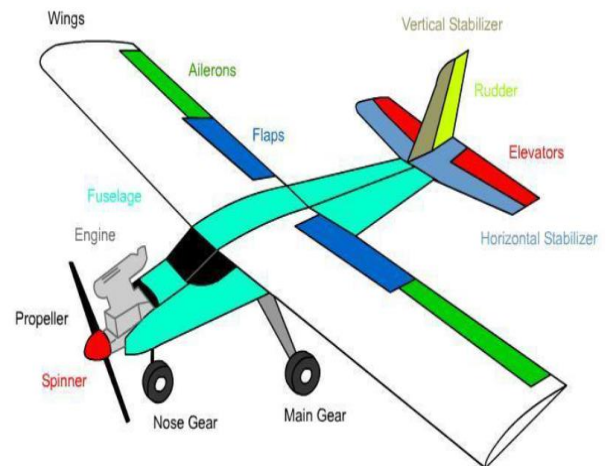

Fig 2: Plane components

A typical plane is shown in above fig 2, in this case a remote controlled model plane. Most aircraft look similar to this, because this configuration (arrangement of components) is very stable and flies well. Other aircraft have various alterations to this design, depending on what the aircraft is designed to do. Some aircraft have a lower wing, some have different tail arrangements and some have large floats to land on water. Some unusual designs also have more than one wing, and some have more than one fuselage. Most pilots learn to fly on a plane like the one shown above, however, because these planes are simple to fly, and many designers start with simple designs like this before moving on to more complex aircraft.

Elevators

Elevators are located on the back of the plane's horizontal tail and are used to make the plane climb or dive. The horizontal tail, usually at the back, has a similar shape to a wing (an airfoil) and produces lift. The purpose of the tail produces more lift, the nose of the plane will go down and the plane will dive. Likewise, if the tail produces less lift, the nose of the plane will go up and the plane will climb.

Elevators change the amount of lift produced by the horizontal tail by changing the shape of the airfoil. Airfoils are usually curved like an arch, and this is one of the reasons air moves slower beneath the wings than above them. The more curved an airfoil is, the more lift it will produce. By moving the elevator at the end of a wing down, the airfoil becomes more curved and produces more lift. Likewise, by moving the elevator up, the wing is effectively less curved and produces less lift.

Ailerons

Ailerons are located on the tips of the wings and are used to control roll. Ailerons work the same way that elevators do, by moving up and down to change the shape of the airfoil and produce more or less lift. By moving one aileron up and the other down, one wing will generate less lift than the other. The wing that generates less lift will drop, and the one that generates more will rise, and this will cause the plane to roll.

When a plane rolls, the lift produced by the wings is no longer acting straight upwards, but is now acting upwards and towards the lower of the two wings. Because of this, the plane will now turn towards the low wing. Because of this, ailerons can be used to steer planes left or right.

Rudder(s)

A rudder is located on the plane's vertical tail and is used to steer the plane left or right. Some aircraft have more than one vertical tail, like the FA-18 fighter jet, and each tail has its own rudder. The vertical tail on a plane is also an airfoil shape, but the airfoil is not curved. As a result, the vertical tail does not normally generate lift. When the rudder is moved in one direction, the vertical tail is effectively curved, and produces lift. However, this lift does not act vertically, as the vertical tail is not horizontal like the wing. Lift always acts perpendicular to the wing or tail that generates it, so the lift generated by the vertical tail will act horizontally. This lift will cause the plane to rotate left or right. If the rudder is moved to the left, it will generate lift to the right, which will move the nose of the plane to the left. Rudders are often slower at turning an aircraft than the ailerons, but they can turn the aircraft without rolling it and are useful

for small adjustments during takeoff, landing and other flights. Sometimes a pilot uses both the rudder and the ailerons together while turning in order to produce a smoother flight.

Throttle(s)

A throttle controls the thrust produced by an engine and is used to make the plane go faster or slower. Planes with more than one engine, like passenger jets, will have one throttle for each engine. The way that the throttle works depends on the type of engine, but it will generally increase the amount of fuel being consumed by the engine, which will in turn generate more heat or spin a propeller faster. Depending on the position of the engines, increasing the throttle may also cause the plane to climb, roll or turn. In fact, computer programs have been written that allow planes with two or more engines to be flown and landed using only the throttles. These programs are to help aircraft to land safely when the other controls have failed, and are not used very often.

4. RESULTS

4.1 LOAD CALCULATIONS

All-up weight of the aircraft considered for the analysis is 2000 kg. (4-seater aircraft)

Weight = 2000kg

Design load factor = 3

Total load acting on aircraft = $2000 \times 3 = 6000\text{kg}$

FOS = 1.5

Design load = $6000 \times 1.5 = 9000\text{kg}$

Lift load experienced by both fuselage and wing

Lift load on the wing = 80% of total load

$$= 0.8 \times 9000$$

$$= 7200\text{kg}$$

Load acting on each wing = $7200/2$

$$= 3600\text{kg} = 35303.94\text{N}$$

Pressure = $35303.94\text{N}/9$

$$= 3922.5\text{ Pa}$$

ρ = air density = $1.225\text{Kg}/\text{m}^3$

Inlet velocity = $18\text{m}/\text{s}$

Chord length = 1m

$$L = \frac{1}{2} \rho v^2 \times C_l \times A = 0.5 \times 1.225 \times 18^2 \times 0.5 \times 5 \times 0.1 = 49.61 \text{N}$$

$$D = \frac{1}{2} \rho v^2 \times C_d \times A = 0.5 \times 1.225 \times 18^2 \times 0.008 \times 5 \times 0.1 \times 2 = 15.87 \text{N}$$

4.2 SOLID MODELLING OF NACA4412 AIRFOIL

The solid modeling of the airfoil was made with the help of CAD tools CATIA v5 as shown in Figure. The chord of the airfoil was selected as 1m and extruded to a wing span of 9m. By using the NACA 4412 coordinates, we can prepare the aircraft wing. Fig 43 shows the CATIA 3D model of aircraft wing with NACA 4412 profile.

Table 1: Co ordinates of NACA4412 airfoil

X	Y	X	Y
1	0.0013	0.0125	-0.0143
0.95	0.0147	0.025	-0.0195
0.9	0.0271	0.05	-0.0249
0.8	0.0489	0.075	-0.0274
0.7	0.0669	0.1	-0.0286
0.6	0.0814	0.15	-0.0288
0.5	0.0919	0.2	-0.0274
0.4	0.098	0.25	-0.025
0.3	0.0976	0.3	-0.0226
0.25	0.0941	0.4	-0.018
0.2	0.088	0.5	-0.014
0.15	0.0789	0.6	-0.01
0.1	0.0659	0.7	-0.0065
0.075	0.0576	0.8	-0.0039
0.05	0.0473	0.9	-0.0022
0.025	0.0339	0.95	-0.0016
0.0125	0.0244	1	-0.0013

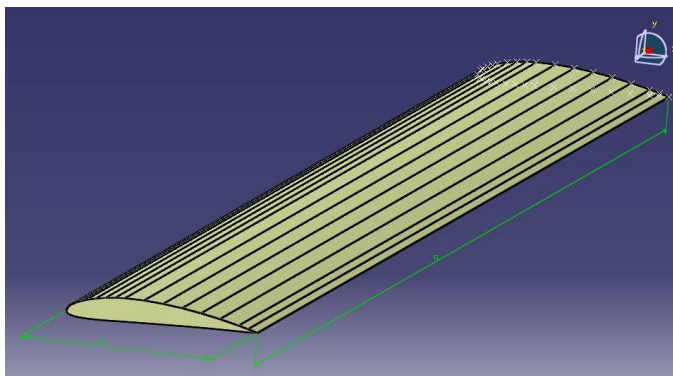

Fig 3: 3D model of aircraft wing

4.3 STRUCTURAL ANALYSIS IN ANSYS

- First, Prepared Assembly in CATIA V5 for wing and Save as this part as IGES for Exporting into Ansys Workbench 14.5 Environment. Import. IGES Model in ANSYS Workbench Simulation Module.
- Apply Material for aircraft wing

Material Details: AA7075 and composite material GLARE (glass-reinforced aluminum laminate)

Table 2: Properties of AA7075

Youngs modulus	7.17E+10 Pa
Density	2810 Kg/m ³
Poissons ratio	0.33
Bulk modulus	7.092E+10 Pa
Shear modulus	2.6955E+10 Pa

Table 3: Properties of GLARE

Young's modulus	2.7E+11 Pa
Density	1760 Kg/m ³
Poissons ratio	0.36
Bulk modulus	3.2143E+11 Pa
Shear modulus	9.9265E+10 Pa

- Mesh the aircraft wing
- Define boundary condition for Analysis
Boundary conditions play an important role in finite element calculation here, one end is fixed.
- Define type of Analysis for both AA7075 and composite material GLARE Type of Analysis:- Static Structural
- Apply the pressure on aircraft wing
- Run the Analysis
- Get the Results

4.3.1 Structural analysis of Aircraft wing AA 7075:

A static analysis calculates the effects of steady loading conditions on a structure, while ignoring inertia and damping effects, such as those caused by time varying loads. A static analysis can, however. Include steady inertia loads (such as gravity and rotational velocity), and time varying loads that can be approximated as static equivalent loads.

Static analysis determines the displacements, stresses, strains and forces in structures and components caused by loads that do not induce significant inertia and damping effect. Steady loading and response conditions are assumed; that is, the loads and structures response are assumed to vary slowly with respect to time.

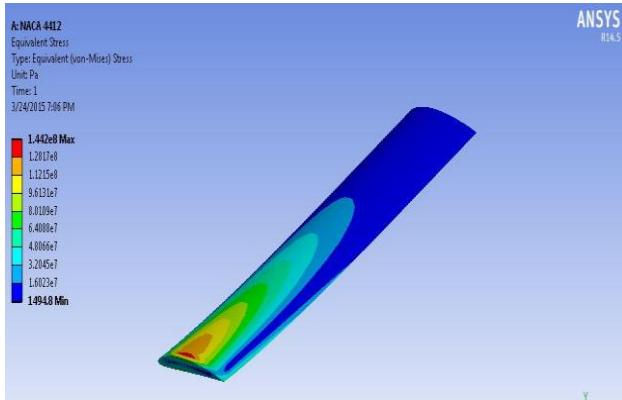

Fig 4: von-mises stress of AA7075

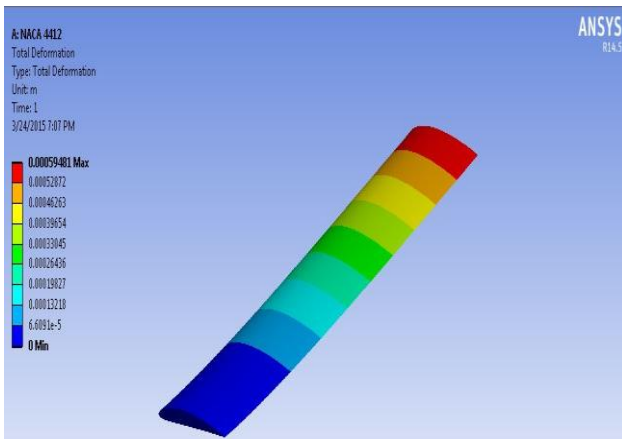

Fig 5: Total deformation of AA7075

4.3.2 Structural analysis of composite aircraft wing:

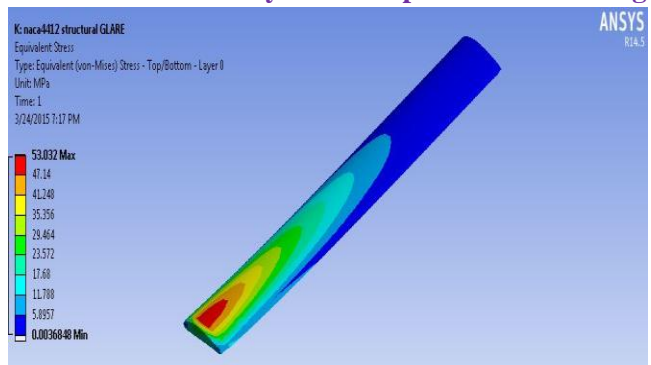

Fig 6: von-mises stress of composite aircraft wing

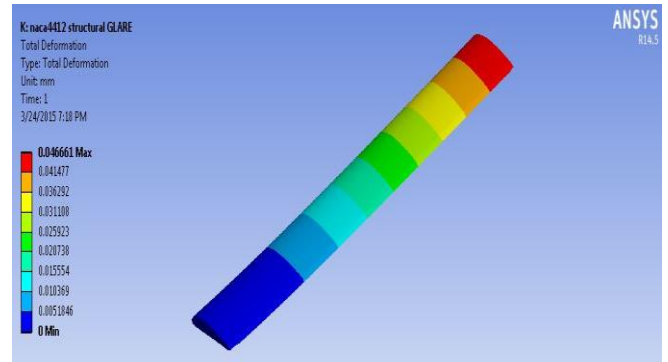

Fig 7: Total deformation of composite aircraft wing

4.4 MODAL ANALYSIS OF AIRCRAFT WING

Modal analysis is used to determine the natural frequencies and mode shapes of a continuous structure.

- Build the model
- Same as for static analysis
- Use top-down or bottom-up techniques
- Apply loads and obtain solution
- Only valid loads are zero-value displacement constraints
- Other loads can be specified but are ignored
- Expand the modes and review results

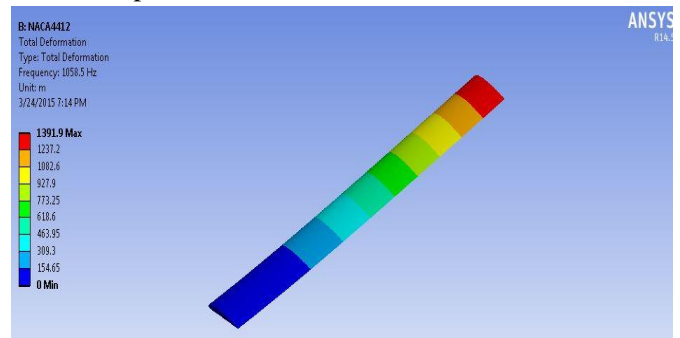

Fig 8: 1st mode

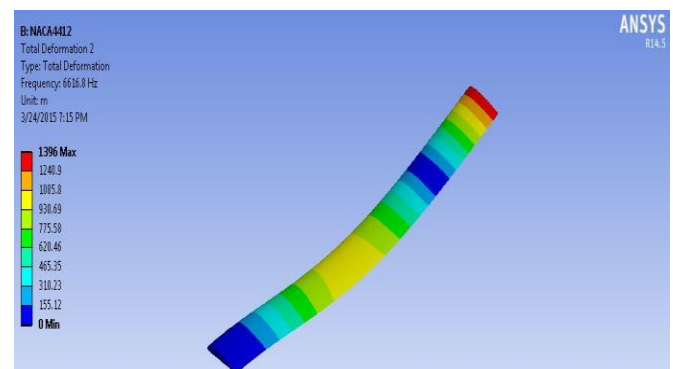

Fig 9: 2nd mode

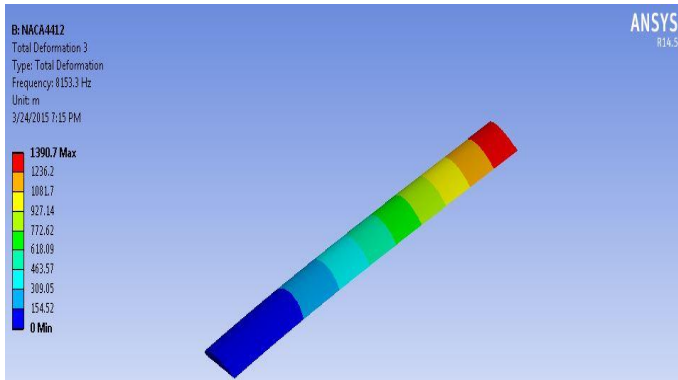

Fig 10: 3rd mode

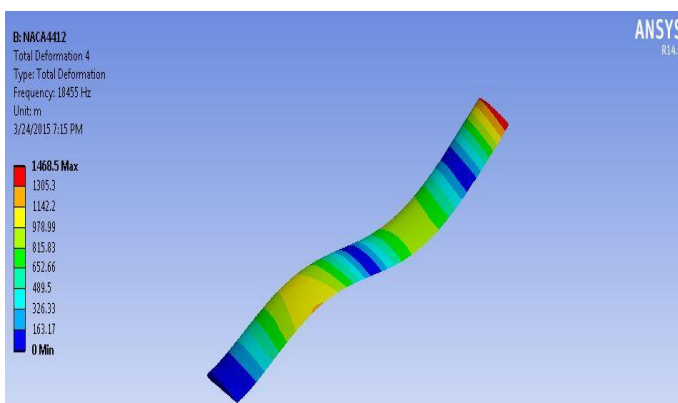

Fig 11: 4th mode

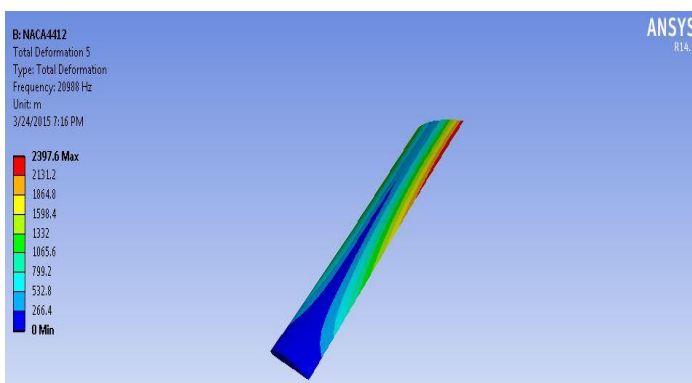

Fig 12: 5th mode

5 CONCLUSIONS

In this Project, the aircraft wing model was created by CATIA V5 R20 software. Then, the model created by CATIA was imported to ANSYS 14.5 software. We observed, aircraft wing with AA7075 obtained 144MPa and for the composite material, we obtained 53.03MPa only. By using the composite material GLARE less stresses had developed on aircraft wing. An aircraft wing

with AA7075 obtained 0.59mm and for the composite material, we obtained 0.046mm only. By using the composite material GLARE less deformation had developed on aircraft wing. It is observed from the fluent analysis; dynamic pressure on leading edge is decreasing with increasing the angle of attack. It is observed from the fluent analysis; static pressure on lower surface is increasing with increasing the angle of attack. We also conclude that static pressure is increased with increasing the angle of attack is increased. Dynamic pressure on lower surface is decreasing with increasing angle of attack whereas; static pressure is increasing on lower surface. We conclude that dynamic pressure is increased with increasing the angle of attack is increased.

Maximum dynamic pressure occurs at upper surface near and around maximum camber and minimum static pressure occurs at and around the same location. We also seen that the minimum dynamic pressure and maximum static pressure occurs at the leading edge of the airfoil, this is the stagnation point. The stagnation point has moved further away from the leading edge. Therefore, as the angle of attack is increased the stagnation point moves away from leading edge on the lower surface of the airfoil. From the contours of the fluent analysis of NACA 4412 airfoil conclude that at 0° pressure coefficient of upper surface indicate negative pressure. When increase the angle of attack we can understand the decrease the pressure coefficient on upper surface and increase on lower Surface also became the maximum at 8°.

REFERENCES

- [1]P. Mohan, D. Marin, S. Sultan, and A. Deen, "Medinet: personalizing the self-care process for patients with diabetes and cardiovascular disease using mobile telephony." Conference Proceedings of the International Conference of IEEE Engineering in Medicine and Biology Society , vol. 2008, no. 3, pp. 755–758.[Online]. Available:<http://www.ncbi.nlm.nih.gov/pubmed/19162765>
- [2] A. Tsanas, M. Little, P. McSharry, and L. Ramig, "Accurate tele monitoring of parkinson's disease

progression by noninvasive speech tests,” *Biomedical Engineering, IEEE Transactions on* , vol. 57, no. 4, pp. 884–893, 2010.

[3] G. Clifford and D. Clifton, “Wireless technology in disease management and medicine,” *Annual Review of Medicine*, vol. 63, pp. 479–492, 2012.

[4] L. Ponemon Institute, “Americans’ opinions on healthcare privacy, available: <http://tinyurl.com/4atsdlj>,” 2010.

[5] A. V. Dhukaram, C. Baber, L. Elloumi, B.-J. van Beijnum, and P. D. Stefanis, “End-user perception towards pervasive cardiac healthcare services: Benefits, acceptance, adoption, risks, security, privacy and trust,” in *PervasiveHealth* , 2011, pp. 478–484.

[6] M. Delgado, “The evolution of health care it: Are current u.s. privacy policies ready for the clouds?” in *SERVICES*, 2011, pp. 371–378.

[7] N. Singer, “When 2+ 2 equals a privacy question,” *New York Times*, 2009.

[8] E. B. Fernandez, “Security in data intensive computing systems,” in *Handbook of Data Intensive Computing* , 2011, pp. 447–466.

[9] A. Narayanan and V. Shmatikov, “Myths and fallacies of personally identifiable information,” *Communications of the ACM*, vol. 53, no. 6, pp. 24–26, 2010.

[10] P. Baldi, R. Baronio, E. D. Cristofaro, P. Gasti, and G. Tsudik, “Countering gattaca: efficient and secure testing of fully-sequenced human genomes,” in *ACM Conference on Computer and Communications Security* , 2011, pp. 691–702.

[11] A. Cavoukian, A. Fisher, S. Killen, and D. Hoffman, “Remote home health care technologies: how to ensure privacy? build it in: Privacy by design,”

Identity in the Information Society, vol. 3, no. 2, pp. 363–378, 2010.

[12] A. Narayanan and V. Shmatikov, “Robust de-anonymization of large sparse datasets,” in *Security and Privacy, 2008. SP 2008. IEEE Symposium on* . IEEE, 2008, pp. 111–125.

[13] “De-anonymizing social networks,” in *IEEE Symposium on Security and Privacy* . IEEE Computer Society, 2009, pp. 173–187.

[14] I. Neamatullah, M. Douglass, L. Lehman, A. Reisner, M. Villarroel, W. Long, P. Szolovits, G. Moody, R. Mark, and G. Clifford, “Automated de-identification of free-text medical records,” *BMC medical informatics and decision making* , vol. 8, no. 1, p. 32, 2008.

[15] S. Al-Fedaghi and A. Al-Azmi, “Experimentation with personal identifiable information,” *Intelligent Information Management*, vol. 4, no. 4, pp. 123–133, 2012.

[16] J. Domingo-Ferrer, “A three-dimensional conceptual framework for database privacy,” *Secure Data Management* , pp. 193–202, 2007.

[17] T. Lim, *Nanosensors: Theory and Applications in Industry, Healthcare, and Defense* . CRC Press, 2011.

[18] X. Zhou, B. Peng, Y. Li, Y. Chen, H. Tang, and X. Wang, “To release or not to release: evaluating information leaks in aggregate human-genome data,” *Computer Security–ESORICS 2011* , pp. 607–627, 2011.

[19] R. Wang, Y. Li, X. Wang, H. Tang, and X. Zhou, “Learning your identity and disease from research papers: information leaks in genome wide association study,” in *Proceedings of the 16th ACM conference on Computer and communications security*. ACM, 2009, pp. 534–544.



[20] P. Ohm, "Broken promises of privacy: Responding to the surprising failure of anonymization," *UCLA Law Review*, vol. 57, p. 1701, 2010.

[21] P. Institute, "Data loss risks during downsizing," 2009.

[22] P. Dixon, "Medical identity theft: The information crime that can kill you," in *The World Privacy Forum*, 2006, pp. 13–22.

[23] K. E. Emam and M. King, "The data breach analyzer," 2009, [Available at: <http://www.ehealthinformation.ca/dataloss>].